

ACDE

OM-00725-OE05
December 19, 1986

10 SERIES™

INSTALLATION, OPERATION, PARTS LIST, AND MAINTENANCE MANUAL

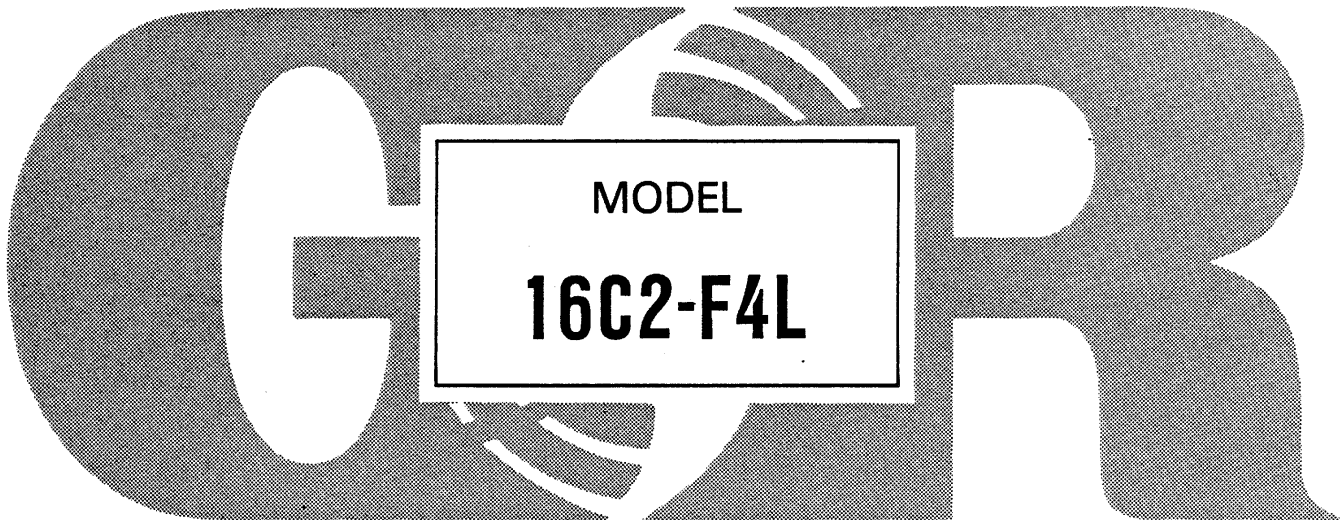

THE GORMAN-RUPP COMPANY • MANSFIELD, OHIO
GORMAN-RUPP OF CANADA LIMITED • ST. THOMAS, ONTARIO, CANADA

Printed in U.S.A.

© Copyright by the Gorman-Rupp Company 1985

TABLE OF CONTENTS

INTRODUCTION	I-1
WARNINGS - SECTION A	A-1
INSTALLATION - SECTION B	B-1
Pump Dimensions	B-1
PREINSTALLATION INSPECTION	B-2
POSITIONING PUMP	B-2
Lifting	B-2
Mounting	B-3
SUCTION AND DISCHARGE PIPING	B-3
Materials	B-3
Line Configuration	B-3
Connections to Pump	B-4
Gauges	B-4
SUCTION LINES	B-4
Fittings	B-4
Strainers	B-4
Sealing	B-5
Suction Lines In Sumps	B-5
Suction Line Positioning	B-5
DISCHARGE LINES	B-6
Siphoning	B-6
Valves	B-6
Bypass Lines	B-7
ALIGNMENT	B-7
OPERATION - SECTION C	C-1
PRIMING	C-1
STARTING	C-2
OPERATION	C-2
Lines With a Bypass	C-2
Lines Without a Bypass	C-2
Leakage	C-3
Liquid Temperature And Overheating	C-3
Strainer Check	C-3
Pump Vacuum Check	C-4
STOPPING	C-4
Cold Weather Preservation	C-4
BEARING TEMPERATURE CHECK	C-5
PUMP TROUBLESHOOTING - SECTION D	D-1
PUMP MAINTENANCE AND REPAIR - SECTION E	E-1
PERFORMANCE CURVE	E-1
PUMP MODEL - PARTS LIST	E-3
PUMP END ASSY - PARTS LIST	E-5
DRIVE ASSY - PARTS LIST	E-7
PUMP AND SEAL DISASSEMBLY AND REASSEMBLY	E-8
Back Cover Removal	E-8
Suction Check Valve Removal	E-9
Pump Casing Removal	E-9
Impeller Removal	E-10
Seal Removal	E-10
Separating Intermediate And Drive Assembly From Engine	E-11
Shaft And Bearing Removal And Disassembly	E-11
Shaft and Bearing Reassembly And Installation	E-12
Securing Intermediate And Drive Assembly To Engine	E-13
Seal Installation	E-14
Impeller Installation And Adjustment	E-16
Suction Check Valve Installation	E-17

Back Cover Installation	E-17
Final Pump Reassembly	E-17
LUBRICATION	E-18
Seal Assembly	E-18
Bearings	E-18
Engine	E-19

INTRODUCTION

This Installation, Operation, and Maintenance Manual is designed to help you achieve the best performance and longest life from your Gorman-Rupp pump.

This pump is a 10 Series, semi-open impeller, self-priming centrifugal model with a suction check valve. The pump is powered by a Deutz Diesel engine, model F4L-912. It is designed for handling dirty water containing specified entrained solids. The basic material of construction for wetted parts is gray iron, with ductile iron impeller and steel wearing parts.

If there are any questions regarding the pump or its application which are not covered in this manual or in other literature accompanying this unit, please contact your Gorman-Rupp distributor, or write:

The Gorman-Rupp Company
P.O. Box 1217
Mansfield, Ohio 44901-1217

or

Gorman-Rupp of Canada Limited
70 Burwell Road
St. Thomas, Ontario N5P 3R7

For information or technical assistance on the engine, contact the engine manufacturer's local dealer or representative.

The following are used to alert maintenance personnel to procedures which require special attention, to those which could damage equipment, and to those which could be dangerous to personnel:

NOTE

Instructions to aid in installation, operation, and maintenance or which clarify a procedure.

CAUTION

Instructions which must be followed to avoid causing damage to the product or other equipment incidental to the installation. These instructions describe the requirements and the possible damage which could result from failure to follow the procedures.

WARNING

////////////////////////////////////
//
// These instructions must be followed to avoid causing in- //
// jury or death to personnel, and describe the procedure //
// required and the injury which could result from failure //
// to follow the procedure. //
//
////////////////////////////////////

WARNINGS

WARNINGS - SECTION A

THESE WARNINGS APPLY TO 10 SERIES ENGINE DRIVEN PUMPS. REFER TO THE MANUAL ACCOMPANYING THE ENGINE BEFORE ATTEMPTING TO BEGIN OPERATION.

WARNING

```

////////////////////////////////////
//
// Before attempting to open or service the pump:
//
// 1. Familiarize yourself with this manual.
// 2. Switch off the engine ignition and remove the key
//    to ensure that the pump will remain inoperative.
// 3. Allow the pump to cool if overheated.
// 4. Vent the pump slowly and cautiously.
// 5. Close the suction and discharge valves.
// 6. Check the temperature before opening any covers,
//    plates, or plugs.
// 7. Drain the pump.
//
////////////////////////////////////

```

WARNING

```

////////////////////////////////////
//
// This pump is designed to handle dirty water containing
// specified entrained solids. Do not attempt to pump vol-
// atile, flammable, or corrosive liquids which may damage
// the pump or endanger personnel as a result of pump fail-
// ure.
//
////////////////////////////////////

```

WARNING

```

////////////////////////////////////
//
// Use lifting and moving equipment in good repair and with
// adequate capacity to prevent injuries to personnel or
// damage to equipment. The bail is intended for use in
// lifting the pump assembly only. Suction and discharge
// hoses and piping MUST be removed from the pump when
// lifting the pump by the bail.
//
////////////////////////////////////

```

WARNING

```

////////////////////////////////////
//
// After the pump has been positioned, make certain that
// the pump and all piping or hose connections are tight,
// properly supported and secure before operation.
//
////////////////////////////////////

```

WARNINGS

WARNING

```

////////////////////////////////////
//
// Do not operate the pump against a closed discharge valve //
// for long periods of time. This could bring the liquid //
// to a boil, build pressure, and cause the pump to rupture //
// or explode. //
// //
////////////////////////////////////

```

WARNING

```

////////////////////////////////////
//
// Do not remove plates, covers, gauges, pipe plugs, or //
// fittings from an overheated pump. Vapor pressure within //
// the pump can cause parts being disengaged to be ejected //
// with great force. Allow the pump to cool before servic- //
// ing. //
// //
////////////////////////////////////

```

WARNING

```

////////////////////////////////////
//
// Do not operate an internal combustion engine in an ex- //
// plosive atmosphere. When operating internal combustion //
// engines in an enclosed area, make certain that exhaust //
// fumes are piped to the outside. These fumes contain //
// carbon monoxide, a deadly gas that is colorless, //
// tasteless, and odorless. //
// //
////////////////////////////////////

```

WARNING

```

////////////////////////////////////
//
// Fuel used by internal combustion engines presents an ex- //
// treme explosion and fire hazard. Make certain that all //
// fuel lines are securely connected and free of leaks. //
// Never refuel a hot or running engine. Avoid overfilling //
// the fuel tank. Always use the correct type of fuel. //
// //
////////////////////////////////////

```

WARNING

```

////////////////////////////////////
//
// Never tamper with the governor to gain more power. The //
// governor establishes safe operating limits that should //
// not be exceeded. The maximum continuous operating speed //
// is 1900 RPM. //
// //
////////////////////////////////////

```

INSTALLATION

INSTALLATION - SECTION B

Since pump installations are seldom identical, this section offers only general recommendations and practices required to inspect, position, and arrange the pump and piping.

Most of the information pertains to a standard **static lift application** where the pump is positioned above the free level of liquid to be pumped.

If installed in a **flooded suction application** where the liquid is supplied to the pump under pressure, some of the information such as mounting, line configuration, and priming must be tailored to the specific application. Since the pressure supplied to the pump is critical to performance and safety, **be sure** to limit the incoming pressure to 50% of the maximum permissible operating pressure as shown on the pump performance curve. (See Section E, Page 1). If the pump is fitted with a Gorman-Rupp double grease lubricated seal, the maximum incoming pressure must be reduced to 10 p.s.i..

For further assistance, contact your Gorman-Rupp distributor or the Gorman-Rupp Company.

Pump Dimensions

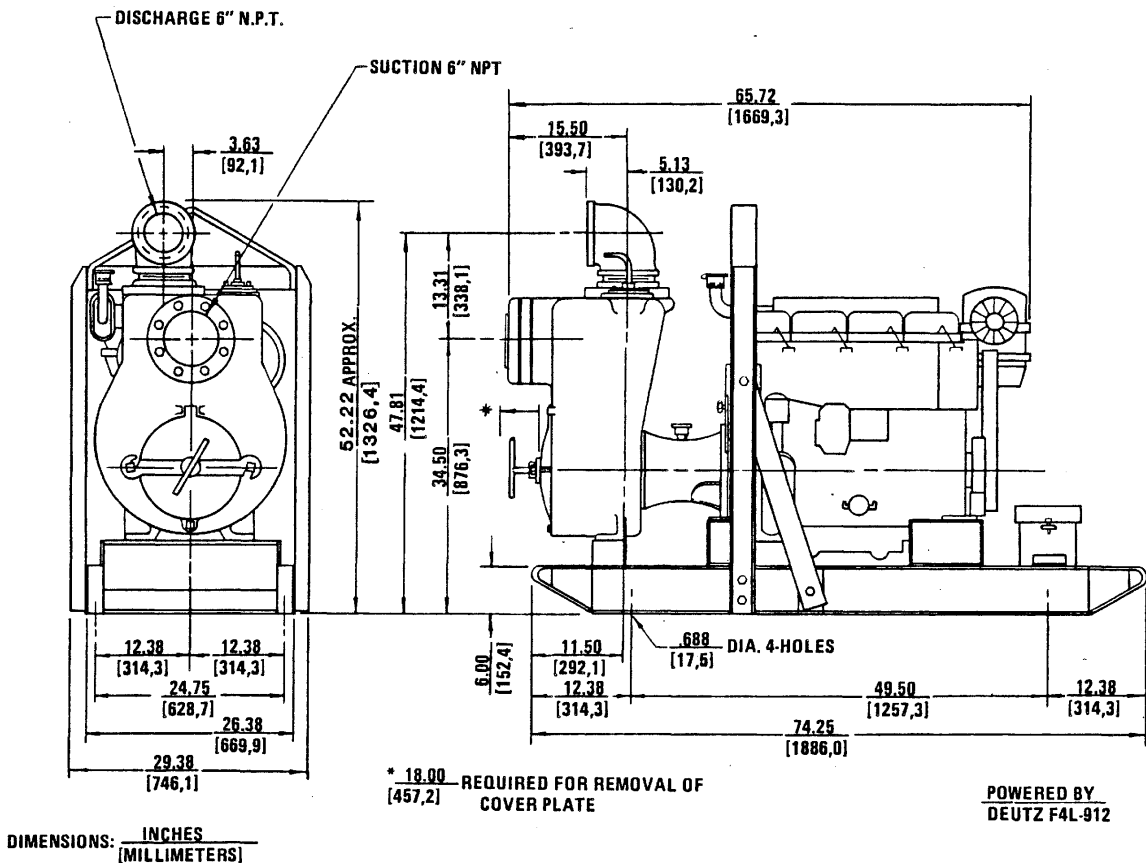

Figure 1. Pump Model 16C2-F4L

INSTALLATION

PREINSTALLATION INSPECTION

The pump assembly was inspected and tested before shipment from the factory. Before installation, inspect the pump for damage which may have occurred during shipment. Check as follows:

- a. Inspect the pump and engine for cracks, dents, damaged threads, and other obvious damage.
- b. Check for and tighten loose attaching hardware. Since gaskets tend to shrink after drying, check for loose hardware at mating surfaces.
- c. Carefully read all tags, decals, and markings on the pump assembly, and follow the instructions indicated.
- d. Check all lubricant levels and lubricate as necessary. Refer to LUBRICATION in the MAINTENANCE AND REPAIR section of this manual and perform duties as instructed.
- e. If the pump and engine have been stored for more than 12 months, some of the components or lubricants may have exceeded their maximum shelf life. **These must be inspected or replaced** to ensure maximum pump service.

If the maximum shelf life has been exceeded, or if anything appears to be abnormal, contact your Gorman-Rupp distributor or the factory to determine the repair or updating policy. **Do not** put the pump into service until appropriate action has been taken.

POSITIONING PUMP

WARNING

```

////////////////////////////////////
//                               //
// Use lifting and moving equipment in good repair and with //
// adequate capacity to prevent injuries to personnel or //
// damage to equipment. The bail is intended for use in //
// lifting the pump assembly only. Suction and discharge //
// hoses and piping MUST be removed from the pump when //
// lifting the pump by the bail.                               //
//                               //
////////////////////////////////////

```

Lifting

Use lifting equipment with a capacity of at least **10,000 pounds**. This pump weighs approximately **1,985 pounds**, not including the weight of accessories and wheel kit. Customer installed equipment such as suction and discharge hoses **must** be removed before attempting to lift.

CAUTION

The pump assembly can be seriously damaged if the cables or chains used to lift and move the unit are improperly wrapped around the pump.

Mounting

Locate the pump in an accessible place as close as practical to the liquid being pumped. Level mounting is essential for proper operation. The pump may have to be supported or shimmed to provide for level operation or to eliminate vibration.

If the pump has been mounted on a moveable base, make certain the base is stationary by setting the brake and blocking the wheels before attempting to operate the pump.

To ensure sufficient lubrication and fuel supply to the engine, **do not** position the pump and engine more than 15° off horizontal for continuous operation. The pump and engine may be positioned up to 30° off horizontal for **intermittent operation only**; however, the engine manufacturer should be consulted for continuous operation at angles greater than 15°.

SUCTION AND DISCHARGE PIPING**Materials**

Either pipe or hose may be used for suction and discharge lines; however, the materials must be compatible with the liquid being pumped. If hose is used in suction lines, it must be the rigid-wall, reinforced type to prevent collapse under suction. Using piping couplings in suction lines is not recommended.

Line Configuration

Keep suction and discharge lines as straight as possible to minimize friction losses. Make minimum use of elbows and fittings, which substantially increase friction loss. If elbows are necessary, use the long-radius type to minimize friction loss.

Connections to Pump

Before tightening a connecting flange, align it exactly with the pump port. Never pull a pipe line into place by tightening the flange bolts and/or couplings.

Lines near the pump must be independently supported to avoid strain on the pump which could cause excessive vibration, decreased bearing life, and increased shaft and seal wear. If hose-type lines are used, they should have adequate support to secure them when filled with liquid and under pressure.

Gauges

Most pumps are drilled and tapped for installing discharge pressure and vacuum suction gauges. If these gauges are desired for pumps that are not tapped, drill and tap the suction and discharge lines not less than 18 inches from the suction and discharge ports and install the lines. Installation closer to the pump may result in erratic readings.

SUCTION LINES

To avoid air pockets which could affect pump priming, the suction line must be as short and direct as possible. When operation involves a suction lift, the line must always slope upward to the pump from the source of the liquid being pumped; if the line slopes down to the pump at any point along the suction run, air pockets will be created.

Fittings

Suction lines should be the same size as the pump inlet. If reducers are used in suction lines, they should be the eccentric type, and should be installed with the flat part of the reducers uppermost to avoid creating air pockets. Valves are not normally used in suction lines, but if a valve is used, install it with the stem horizontal to avoid air pockets.

Strainers

If a strainer is furnished with the pump, be certain to use it; any spherical solids which pass through a strainer furnished with the pump will also pass through the pump itself.

If a strainer is not furnished with the pump, but is installed by the pump user, make certain that the total area of the openings in the strainer is at least three or four times the cross section of the suction line, and that the openings will not permit passage of solids larger than the solids handling capability of the pump.

This pump is designed to handle up to 3 inch diameter spherical solids.

Sealing

Since even a slight leak will affect priming, head, and capacity, especially when operating with a high suction lift, all connections in the suction line should be sealed with pipe dope to ensure an airtight seal. Follow the sealant manufacturer's recommendations when selecting and applying the pipe dope. The pipe dope should be compatible with the liquid being pumped.

Suction Lines In Sumps

If a single suction line is installed in a sump, it should be positioned away from the wall of the sump at a distance equal to one and one-half times the diameter of the suction line.

If there is a liquid flow from an open pipe into the sump, the flow should be kept away from the suction inlet because the inflow will carry air down into the sump, and air entering the suction line will reduce pump efficiency.

If it is necessary to position inflow close to the suction inlet, install a baffle between the inflow and the suction inlet at a distance one and one-half times the diameter of the suction pipe. The baffle will allow entrained air to escape from the liquid before it is drawn into the suction inlet.

If two suction lines are installed in a single sump, the flow paths may interact, reducing the efficiency of one or both pumps. To avoid this, position the suction inlets so that they are separated by a distance equal to at least three times the diameter of the suction pipe.

Suction Line Positioning

The depth of submergence of the suction line is critical to efficient pump operation. Figure 2 shows recommended minimum submergence vs. velocity.

NOTE

The pipe submergence required may be reduced by installing a standard pipe increaser fitting at the end of the suction line. The larger opening size will reduce the inlet velocity. Calculate the required submergence using the following formula based on the increased opening size (area or diameter).

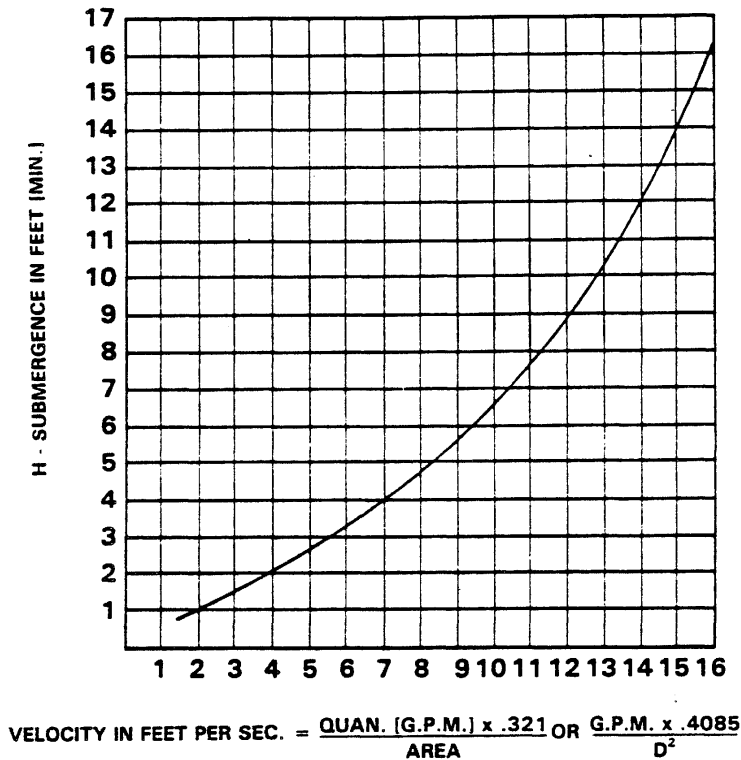

Figure 2. Recommended Minimum Suction Line Submergence Vs. Velocity

DISCHARGE LINES

Siphoning

Do not terminate the discharge line at a level lower than that of the liquid being pumped unless a siphon breaker is used in the line. Otherwise, a siphoning action causing damage to the pump could result.

Valves

A check valve in the discharge line is normally recommended, but it is not necessary in low discharge head applications.

If a throttling valve is desired in the discharge line, use a valve as large as the largest pipe to minimize friction losses. Never install a throttling valve in a suction line.

With high discharge heads, it is recommended that a throttling valve and a system check valve be installed in the discharge line to protect the pump from excessive shock pressure and reverse rotation when it is stopped.

Bypass Lines

If it is necessary to permit the escape of air to atmosphere during initial priming or in the repriming cycle, install a bypass line between the pump and the discharge check valve. The bypass line should be sized so that it does not affect pump discharge capacity.

Either a Gorman-Rupp automatic air release valve - which will automatically open to allow the pump to prime, and automatically close when priming is accomplished - or a hand-operated shutoff valve should be installed in the bypass line.

NOTE

The bypass line may clog frequently, particularly if the valve remains closed. If this condition occurs, either use a larger bypass line or leave the shutoff valve open during the pumping operation.

Do not terminate the discharge line at a level lower than that of the liquid being pumped unless a siphon breaker is used in the line. Otherwise, a siphoning action could result, causing damage to the pump.

ALIGNMENT

The alignment of the pump and the engine is critical for trouble free mechanical operation. See Section E, **Securing Intermediate And Drive Assembly To Engine** for detailed information.

OPERATION

OPERATION - SECTION C

WARNING

```

////////////////////////////////////
//
// This pump is designed to handle dirty water containing //
// specified entrained solids. Do not attempt to pump vol- //
// atile, flammable, or corrosive liquids which may damage //
// the pump or endanger personnel as a result of pump fail- //
// ure. //
//
////////////////////////////////////

```

WARNING

```

////////////////////////////////////
//
// Never tamper with the governor to gain more power. The //
// governor establishes safe operating limits that should //
// not be exceeded. The maximum continuous operating speed //
// is 1900 RPM. //
//
////////////////////////////////////

```

PRIMING

Install the pump and piping as described in INSTALLATION. Make sure that the piping connections are tight, and that the pump is securely mounted. Check that the pump is properly lubricated (see LUBRICATION in MAINTENANCE AND REPAIR).

This pump is self-priming, but the pump should never be operated unless there is liquid in the casing.

CAUTION

<p>Never operate a self-priming pump unless there is liquid in the casing. The pump will not prime when dry. Extended operation of a dry pump will destroy the seal assembly.</p>

Add liquid to the pump casing when:

1. The pump is being put into service for the first time.
2. The pump has not been used for a considerable length of time.
3. The liquid in the pump casing has evaporated.

Once the pump casing has been filled, the pump will prime as necessary.

WARNING

```

////////////////////////////////////
//
// After filling the pump casing, reinstall and tighten the //
// fill plug. Do not attempt to operate the pump unless //
// all connecting piping is securely installed. Otherwise, //
// liquid in the pump forced out under pressure could cause //
// injury to personnel. //
// //
////////////////////////////////////

```

To fill the pump, remove the pump casing fill cover or fill plug at the top of the casing and add clean liquid until the pump is filled. Replace the fill cover or fill plug before operating the pump.

STARTING

Consult the operations manual furnished with the engine.

OPERATION

Lines With a Bypass

Either a Gorman-Rupp automatic air release valve or a hand operated shutoff valve may be installed in a bypass line.

If a Gorman-Rupp automatic air release valve has been installed, close the throttling valve in the discharge line. The Gorman-Rupp valve will automatically open to allow the pump to prime, and automatically close when priming has been accomplished. After the pump has been primed, and liquid is flowing steadily from the bypass line, open the discharge throttling valve.

If a hand operated shutoff valve has been installed, close the throttling valve in the discharge line, and open the bypass shutoff valve so that the pump will not have to prime against the weight of the liquid in the discharge line. When the pump has been primed, and liquid is flowing steadily from the bypass line, close the bypass shutoff valve and open the discharge throttling valve.

Lines Without a Bypass

Open all valves in the discharge line and start the power source. Priming is indicated by a positive reading on the discharge pressure gauge or by a quieter operation. The pump may not prime immediately because the suction line must first fill with liquid. If the pump fails to prime within five minutes, stop it and check the suction line for leaks.

After the pump has been primed, partially close the discharge line throttling valve in order to fill the line slowly and guard against excessive shock pres-

OPERATION

sure which could damage pipe ends, gaskets, sprinkler heads, and any other fixtures connected to the line. When the discharge line is completely filled, adjust the throttling valve to the required flow rate.

Leakage

No leakage should be visible at pump mating surfaces, or at pump connections or fittings. Keep all line connections and fittings tight to maintain maximum pump efficiency.

Liquid Temperature And Overheating

The maximum liquid temperature for this pump is 110°F. Do not apply it at a higher operating temperature.

Overheating can occur if operated with the valves in the suction or discharge lines closed. Operating against closed valves could bring the liquid to a boil, build pressure, and cause the pump to rupture or explode. If overheating occurs, stop the pump and allow it to cool before servicing it. Refill the pump casing with cool liquid.

WARNING

```

////////////////////////////////////
//
// Do not remove plates, covers, gauges, pipe plugs, or //
// fittings from an overheated pump. Vapor pressure within //
// the pump can cause parts being disengaged to be ejected //
// with great force. Allow the pump to cool before servic- //
// ing. //
// //
////////////////////////////////////

```

Strainer Check

If a suction strainer has been shipped with the pump or installed by the user, check the strainer regularly, and clean it as necessary. The strainer should also be checked if pump flow rate begins to drop. If a vacuum suction gauge has been installed, monitor and record the readings regularly to detect strainer blockage.

Never introduce air or steam pressure into the pump casing or piping to remove a blockage. This could result in personal injury or damage to the equipment. If backflushing is absolutely necessary, liquid pressure must be limited to 50% of the maximum permissible operating pressure shown on the pump performance curve. (See Section E, Page 1). If the pump is fitted with a Gorman-Rupp double grease lubricated seal, the maximum incoming pressure must be reduced to 10 p.s.i..

Pump Vacuum Check

With the pump inoperative, install a vacuum gauge in the system, using pipe dope on the threads. Block the suction line and start the pump. At operating speed the pump should pull a vacuum of 20 inches or more of mercury. If it does not, check for air leaks in the seal, gasket, or discharge valve.

Open the suction line, and read the vacuum gauge with the pump primed and at operating speed. Shut off the pump. The vacuum gauge reading will immediately drop proportionate to static suction lift, and should then stabilize. If the vacuum reading falls off rapidly after stabilization, an air leak exists. Before checking for the source of the leak, check the point of installation of the vacuum gauge.

STOPPING

Never halt the flow of liquid suddenly. If the liquid being pumped is stopped abruptly, damaging shock waves can be transmitted to the pump and piping system. Close all connecting valves slowly. On engine driven pumps, reduce the throttle speed slowly and allow the engine to idle briefly before stopping.

CAUTION

If application involves a high discharge head, gradually close the discharge throttling valve before stopping the pump.

After stopping the pump, switch off the engine ignition and remove the key to ensure that the pump will remain inoperative.

Cold Weather Preservation

In below freezing conditions, drain the pump to prevent damage from freezing. Also, clean out any solids by flushing with a hose. Operate the pump for approximately one minute; this will remove any remaining liquid that could freeze the pump rotating parts.

If the pump will be idle for more than a few hours, or if it has been pumping liquids containing a large amount of solids, drain the pump, and flush it thoroughly with clean water. To prevent large solids from clogging the drain port and preventing the pump from completely draining, insert a rod or stiff wire in the drain port, and agitate the liquid during the draining process. Clean out any remaining solids by flushing with a hose.

BEARING TEMPERATURE CHECK

Bearings normally run at higher than ambient temperatures because of heat generated by friction. Temperatures up to 160°F are considered normal for bearings, and they can operate safely to at least 180°F.

Checking bearing temperatures by hand is inaccurate. Bearing temperatures can be measured accurately by placing a contact-type thermometer against the housing. Record this temperature for future reference.

A sudden increase in bearing temperatures is a warning that the bearings are at the point of failing to operate properly. Make certain that the bearing lubricant is of the proper viscosity and at the correct level (see LUBRICATION in MAINTENANCE AND REPAIR). Bearing overheating can also be caused by shaft misalignment and/or excessive vibration.

When pumps are first started, the bearings may seem to run at temperatures above normal. Continued operation should bring the temperatures down to normal levels.

PUMP TROUBLESHOOTING - SECTION D

WARNING

```

////////////////////////////////////
//
// Before attempting to open or service the pump:
//
// 1. Familiarize yourself with this manual.
// 2. Switch off the engine ignition and remove the key
//    to ensure that the pump will remain inoperative.
// 3. Allow the pump to cool if overheated.
// 4. Vent the pump slowly and cautiously.
// 5. Close the suction and discharge valves.
// 6. Check the temperature before opening any covers,
//    plates, or plugs.
// 7. Drain the pump.
//
////////////////////////////////////
    
```

TROUBLE	POSSIBLE CAUSE	PROBABLE REMEDY
PUMP FAILS TO PRIME	Not enough liquid in casing.	Add liquid to casing. See PRIMING.
	Suction check valve contaminated or damaged.	Clean or replace check valve.
	Air leak in suction line.	Correct leak.
	Lining of suction hose collapsed.	Replace suction hose.
	Leaking or worn seal or pump gasket.	Check pump vacuum. Replace leaking or worn seal or gasket.
	Suction lift or discharge head too high.	Check piping installation and install bypass line if needed. See INSTALLATION.
	Strainer clogged.	Check strainer and clean if necessary.
PUMP STOPS OR FAILS TO DELIVER RATED FLOW OR PRESSURE	Suction check valve or foot valve clogged or binding.	Clean valve.
	Air leak in suction line.	Correct leak.
	Suction intake not submerged at proper level or sump too small.	Check installation and correct submergence as needed.

TROUBLE	POSSIBLE CAUSE	PROBABLE REMEDY
PUMP STOPS OR FAILS TO DELIVER RATED FLOW OR PRESSURE(cont.)	<p>Lining of suction hose collapsed.</p> <p>Impeller or other wearing parts worn or damaged.</p> <p>Impeller clogged.</p> <p>Suction lift or discharge head too high.</p> <p>Strainer clogged.</p> <p>Pump speed too slow.</p> <p>Leaking or worn seal or pump gasket.</p>	<p>Replace suction hose.</p> <p>Replace worn or damaged parts. Check that impeller is properly centered and rotates freely.</p> <p>Free impeller of debris.</p> <p>Check piping installation and install bypass line if needed. See INSTALLATION.</p> <p>Check strainer and clean if necessary.</p> <p>Check engine output; consult engine operation manual.</p> <p>Check pump vacuum. Replace leaking or worn seal or gasket.</p>
PUMP REQUIRES TOO MUCH POWER	<p>Pump speed too high.</p> <p>Discharge head too low.</p> <p>Liquid solution too thick.</p> <p>Bearing(s) frozen.</p>	<p>Check engine output.</p> <p>Adjust discharge valve.</p> <p>Dilute if possible.</p> <p>Disassemble pump and check bearing(s).</p>
PUMP CLOGS FREQUENTLY	<p>Discharge flow too slow.</p> <p>Suction check valve or foot valve clogged or binding.</p> <p>Liquid solution too thick.</p>	<p>Open discharge valve fully to increase flow rate, and run engine at maximum governed speed.</p> <p>Clean valve.</p> <p>Dilute if possible.</p>

TROUBLE	POSSIBLE CAUSE	PROBABLE REMEDY
EXCESSIVE NOISE	<p>Cavitation in pump.</p> <p>Pumping entrained air.</p> <p>Pump or drive not securely mounted.</p> <p>Impeller clogged or damaged.</p>	<p>Reduce suction lift and/or friction losses in suction line. Record vacuum and pressure gauge readings and consult local representative or factory.</p> <p>Locate and eliminate source of air bubble.</p> <p>Secure mounting hardware.</p> <p>Clean out debris; replace damaged parts.</p>
BEARINGS RUN TOO HOT	<p>Bearing temperature is high, but within limits.</p> <p>Low or incorrect lubricant.</p> <p>Suction and discharge lines not properly supported.</p> <p>Drive misaligned.</p>	<p>Check bearing temperature regularly to monitor any increase.</p> <p>Check for proper type and level of lubricant.</p> <p>Check piping installation for proper support.</p> <p>Align drive properly.</p>

PUMP MAINTENANCE AND REPAIR - SECTION E

MAINTENANCE AND REPAIR OF THE WEARING PARTS OF THE PUMP WILL MAINTAIN PEAK OPERATING PERFORMANCE.

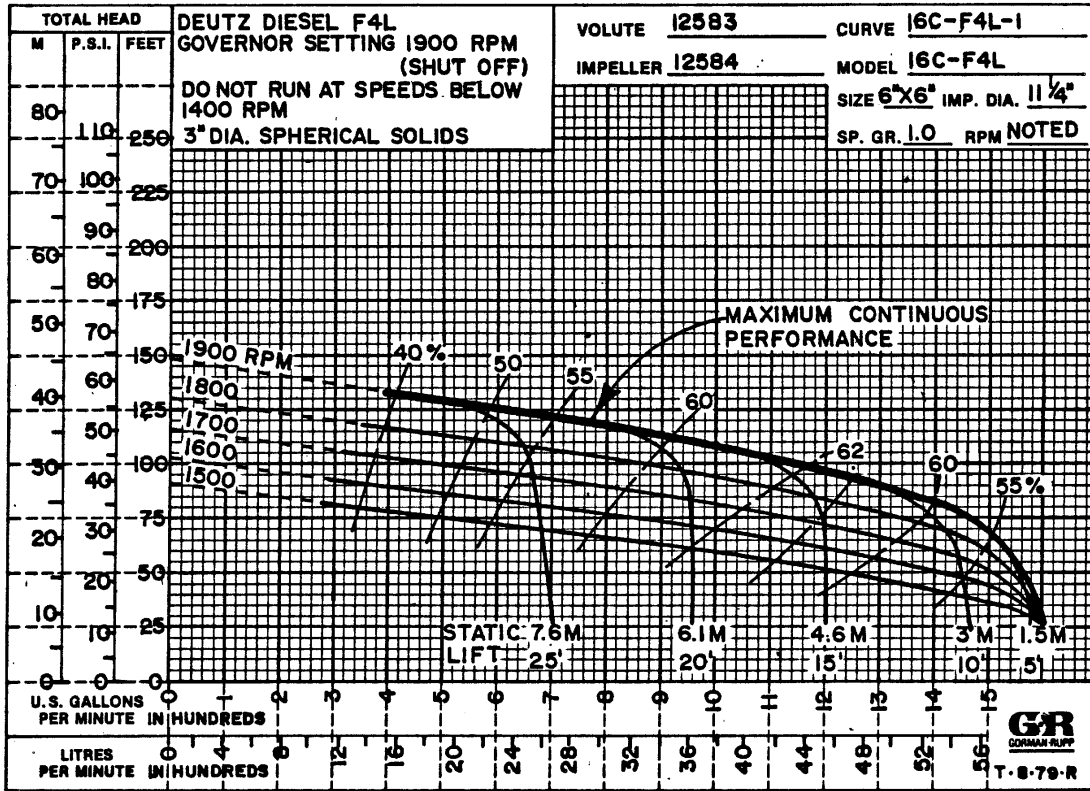

*STANDARD PERFORMANCE FOR PUMP MODEL 16C2-F4L

*Based on 70°F clear water at sea level with minimum suction lift. Since pump installations are seldom identical, your performance may be different due to such factors as viscosity, specific gravity, elevation, temperature, and impeller trim.

If your pump serial number is followed by an "N", your pump is **NOT** a standard production model. Contact the Gorman-Rupp Company to verify performance or part numbers.

CAUTION

Pump speed and operating condition points must be within the continuous performance range shown on the curve.

SECTIONAL DRAWING

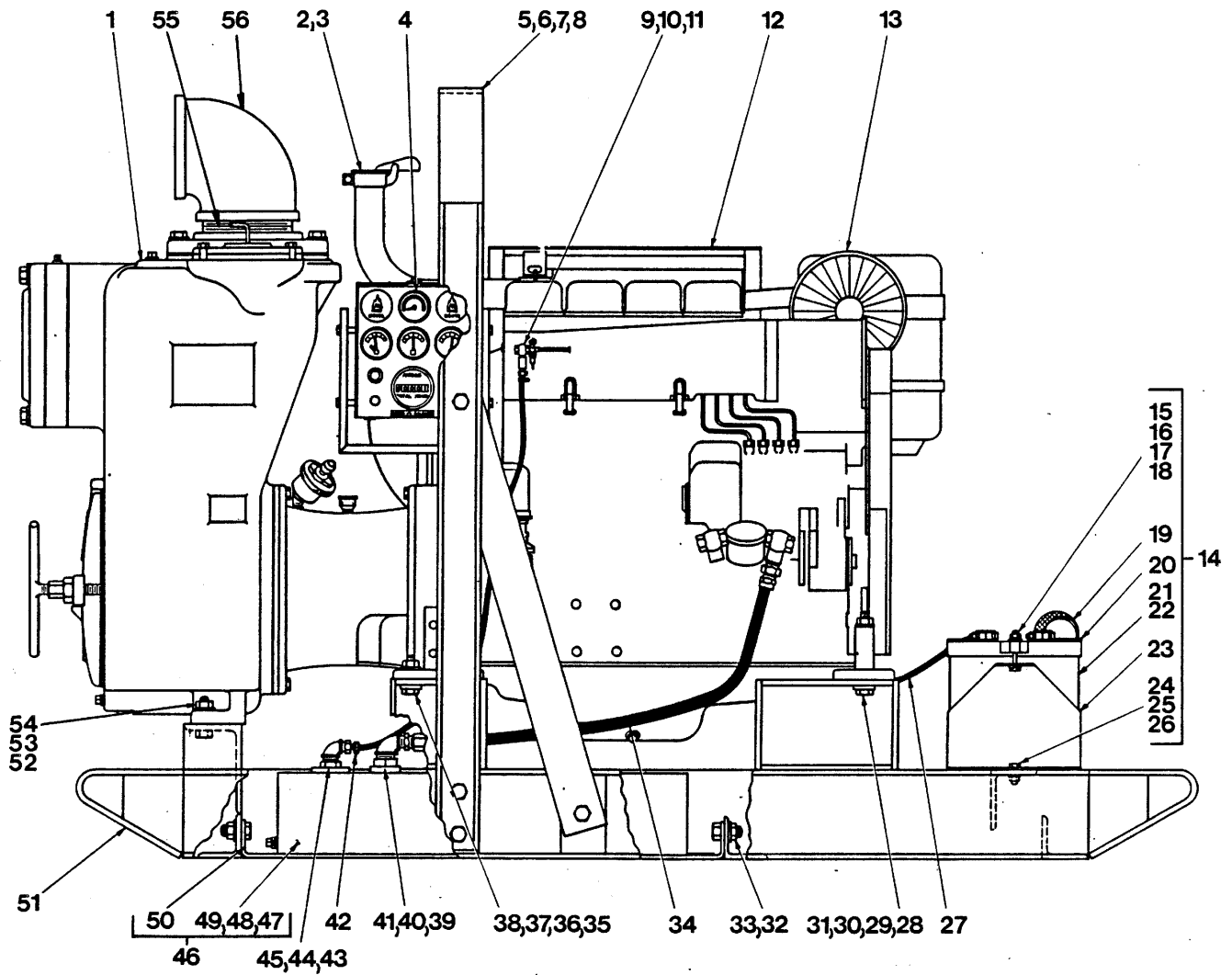

Figure 1. Model 16C2-F4L Pump Assembly

MAINTENANCE AND REPAIR

PARTS LIST
 Pump Model 16C2-F4L
 (From S/N 861130 up)

If your pump serial number is followed by an "N", your pump is NOT a standard production model. Contact the Gorman-Rupp Company to verify part numbers.

ITEM NO.	PART NAME	PART NUMBER	MATL CODE	QTY	ITEM NO.	PART NAME	PART NUMBER	MATL CODE	QTY
1	PUMP END	16C2 (SEE FIGURE 2)		1	31	HEX NUT	D10	15991	2
2	EXHAUST ELBOW	31912-023	15990	1	32	HEX NUT	21765-314	-----	10
3	WEATHER CAP	S1331	-----	1	33	HEX HD CAPSCREW	B0604	15991	10
4	TACHOMETER KIT	48312-606	-----	1	34	FUEL INLET ASSY	9072-L	-----	1
	-ELECTRIC TACH	26861-021	-----	1	35	BEVELED WASHER	21167-011	-----	4
5	HOISTING BAIL	13351-AK	24000	1	36	HEX HD CAPSCREW	B1008	15991	4
6	HEX HD CAPSCREW	B1006	15991	8	37	LOCKWASHER	J10	15991	4
7	LOCKWASHER	J10	15991	8	38	HEX NUT	D10	15991	4
8	HEX NUT	D10	15991	8	39	FUEL OUTLET ASSY	10765	24030	1
9	FUEL RET LINE	11308-A	-----	1	40	REDUCING ELBOW	Q0604	11990	1
10	HOSE CLAMP	26518-642	-----	1	41	MALE CONNECTOR	S1447	-----	1
11	HOSE BARB FITTING	26523-441	-----	1	42	HOSE CLAMP	26518-642	-----	1
12	MUFFLER GUARD ASSY	42331-010	24150	1	43	HOSE CONNECTOR	26523-402	-----	1
13	DEUTZ F4L ENGINE	29217-041	-----	1	44	REDUCING ELBOW	Q0402	11990	1
14	BATTERY BOX ASSY	GRP40-08B	-----	1	45	FUEL RETURN LINE	14294	24030	1
15	-HEX HD CAPSCREW	B0605	15991	2	46	FUEL TANK AND GUARD ASSY	46711-033	-----	1
16	-FLAT WASHER	K06	15991	2	47	-FUEL TANK ASSY	46711-034	24150	1
17	-LOCKWASHER	J06	15991	2	48	-HEX NUT	21765-314	-----	4
18	-HEX NUT	D06	15991	2	49	-FLAT WASHER	K06	15991	4
19 *	-GRND CABLE ASSY	5795-AC	24040	1	50	-GUARD ASSY	42381-017	24150	1
20	-LID ASSY	42113-012	24150	1	51	BASE ASSEMBLY	41566-575	24150	1
21 *	-12V BATTERY	29331-506	-----	1	52	HEX HD CAPSCREW	B1010	15991	2
22	-BATTERY TAG	6588-S	-----	1	53	LOCKWASHER	J10	15991	2
23	-BATTERY BOX ASSY	42431-030	24150	1	54	HEX NUT	D10	15991	2
24	-HEX HD CAPSCREW	B0605	15991	4	55	PIPE NIPPLE	T96	15070	1
25	-LOCKWASHER	J06	15991	4	56	PIPE ELBOW	R96	11990	1
26	-HEX NUT	D06	15991	4		NOT SHOWN:			
27 *	*POS CABLE ASSY	6926-S	24040	1		STRAINER	7823-A	24000	1
28	BEVELED WASHER	21167-011	-----	2		OPTIONAL:			
29	HEX HD CAPSCREW	B1018	15991	2		WHEEL KIT	GRP30-248	-----	1
30	LOCKWASHER	J10	15991	2					

*INDICATES PARTS RECOMMENDED FOR STOCK

Above Serial Numbers Do Not Apply To Pumps Made In Canada.

CANADIAN SERIAL NO AND UP

SECTIONAL DRAWING

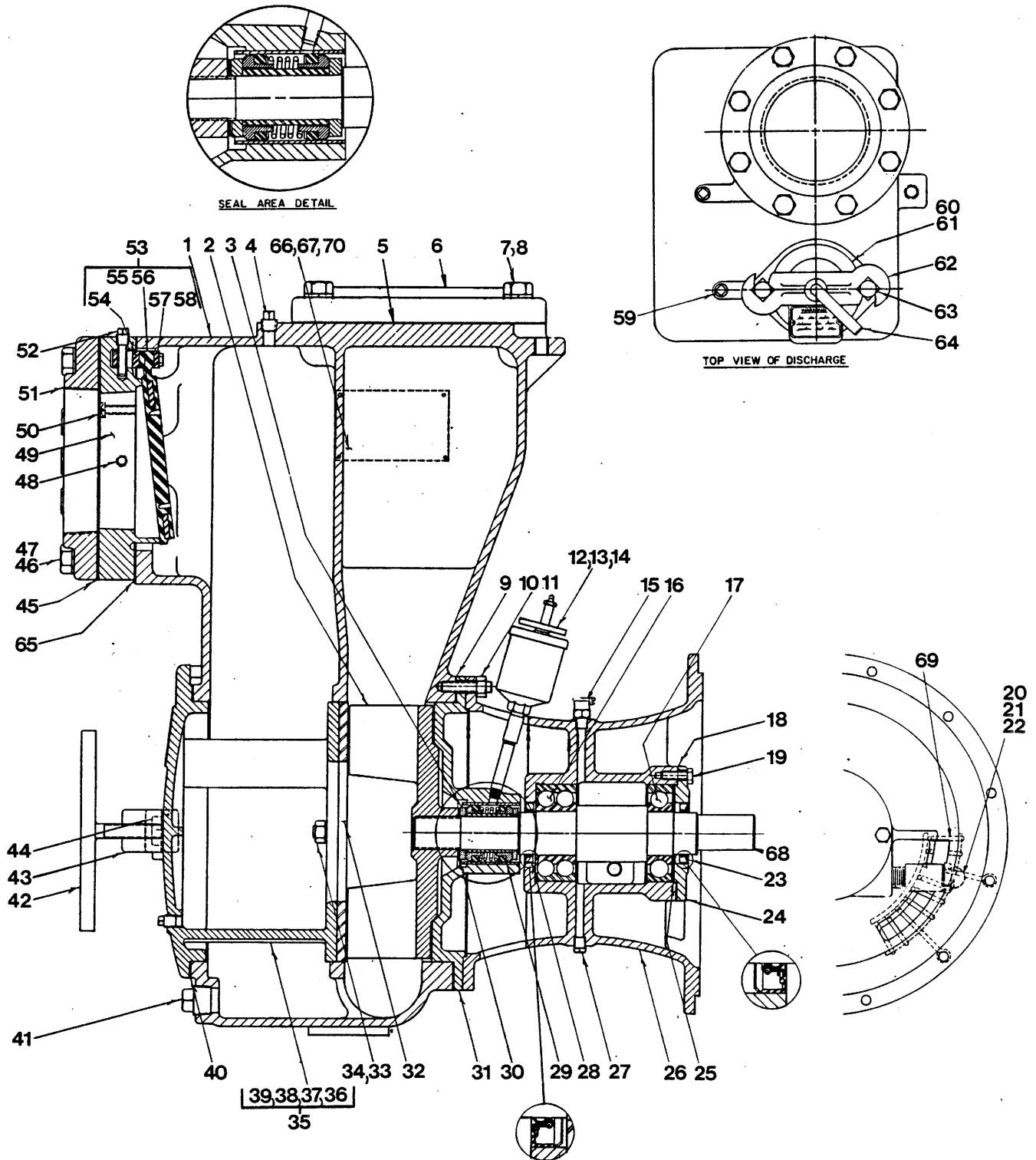

Figure 2. Pump End Assy 16C2-(F4L)

PARTS LIST
Pump End Assy 16C2-(F4L)

ITEM NO.	PART NAME	PART NUMBER	MATL CODE	QTY	ITEM NO.	PART NAME	PART NUMBER	MATL CODE	QTY
1	PUMP CASING	12583	10010	1	39	-DRAIN PLUG	P04	11990	1
2	*IMPELLER	12584	11000	1	40	*COVER GSKT	7668-G	20000	1
3	*SEAL ASSY	GS1500	-----	1	41	CASING DRAIN PLUG	P16	11990	1
4	PIPE PLUG	P04	11990	1	42	COVER CLAMP SCREW	2536	24000	1
5	*DISCH FLANGE GSKT	1679-G	18000	1	43	COVER CLAMP BAR	12586	11000	1
6	DISCHARGE FLANGE	1758	10010	1	44	MACHINE BOLT	A1010	15991	2
7	HEX HD CAPSCREW	B1208	15991	8	45	*SUCTION FLANGE GSKT	1679-G	18000	1
8	LOCKWASHER	J12	15991	8	46	HEX HD CAPSCREW	B1214	15991	8
9	*CASING GSKT SET	34-G	18000	1	47	LOCKWASHER	J12	15991	8
10	STUD	C0809	15991	8	48	PIPE PLUG	P04	11990	1
11	HEX NUT	D08	15991	8	49	*CHECK VALVE SEAT	11402-C	10010	1
12	*SEAL GREASE CUP	S1509	-----	1	50	RD HD MACH SCREW	X0506	14990	2
13	PIPE COUPLING	AE04	11990	1	51	SUCTION FLANGE	1758	10010	1
14	HEAVY PIPE NIPPLE	THA0412	15070	1	52	CHECK VALVE PIN	11645	17010	1
15	OIL HOLE COVER	26717-068	-----	1	53	*CHECK VALVE ASSY	46411-064	-----	1
16	*BALL BEARING	23421-461	-----	1	54	-ADAPTOR	NOT AVAILABLE		1
17	*BALL BEARING	S1077	-----	1	55	-CHECK VALVE	NOT AVAILABLE		1
18	*BEARING CAP GSKT	5413-G	18000	1	56	-SPACER SLEEVE	NOT AVAILABLE		2
19	HEX HD CAPSCREW	B0604	15991	4	57	-BACKUP PLATE	NOT AVAILABLE		1
20	*OIL LEVEL SIGHT GAUGE	S1471	-----	1	58	-HEX HD CAPSCREW	NOT AVAILABLE		2
21	CLOSE NIPPLE	T12	15070	1	59	PIPE PLUG	P04	11990	1
22	PIPE COUPLING	AE12	11990	1	60	FILL COVER ASSY	42111-344	-----	1
23	*OIL SEAL	25258-622	-----	1	61	*FILL COVER GSKT	50-G	19210	1
24	*BEARING CAP	4185-A	10010	1	62	FILL COVER CLAMP BAR	38111-004	11000	1
25	*WAVY WASHER	23963-327	-----	1	63	MACHINE BOLT	A1014	15991	2
26	INTERMEDIATE	38263-614	10010	1	64	FILL COVER CLAMP SCREW	31912-009	15000	1
27	INTERM DRAIN PLUG	P06	11990	1	65	*CHECK VALVE GSKT	11402-G	19370	1
28	*OIL SEAL	25258-622	-----	1	66	NAME PLATE	38818-023	13990	1
29	*SEAL LINER	7408	14010	REF	67	DRIVE SCREW	BM#04-03	15990	4
30	*IMPELLER SHIM SET	5091	17090	REF	68	*IMPELLER SHAFT	38514-807	16040	1
31	*SEAL PLATE	11895-A	10010	1	69	INTERMEDIATE GRD	42381-032	24150	1
32	*WEAR PLATE	2545	15990	1	70	WARNING DECAL	38816-096	-----	1
33	HEX NUT	D08	15991	2		NOT SHOWN:			
34	LOCKWASHER	J08	15991	2		INTERMEDIATE GRD	42381-031	24150	1
35	*BACK COVER ASSY	42111-935	-----	1		OPTIONAL:			
36	-COVER PLATE	NOT AVAILABLE		1		HARDENED IMPELLER	12584	11080	1
37	-WARNING PLATE	2613-EV	13990	1					
38	-DRIVE SCREW	BM#04-03	15990	4					

*INDICATES PARTS RECOMMENDED FOR STOCK

SECTIONAL DRAWING

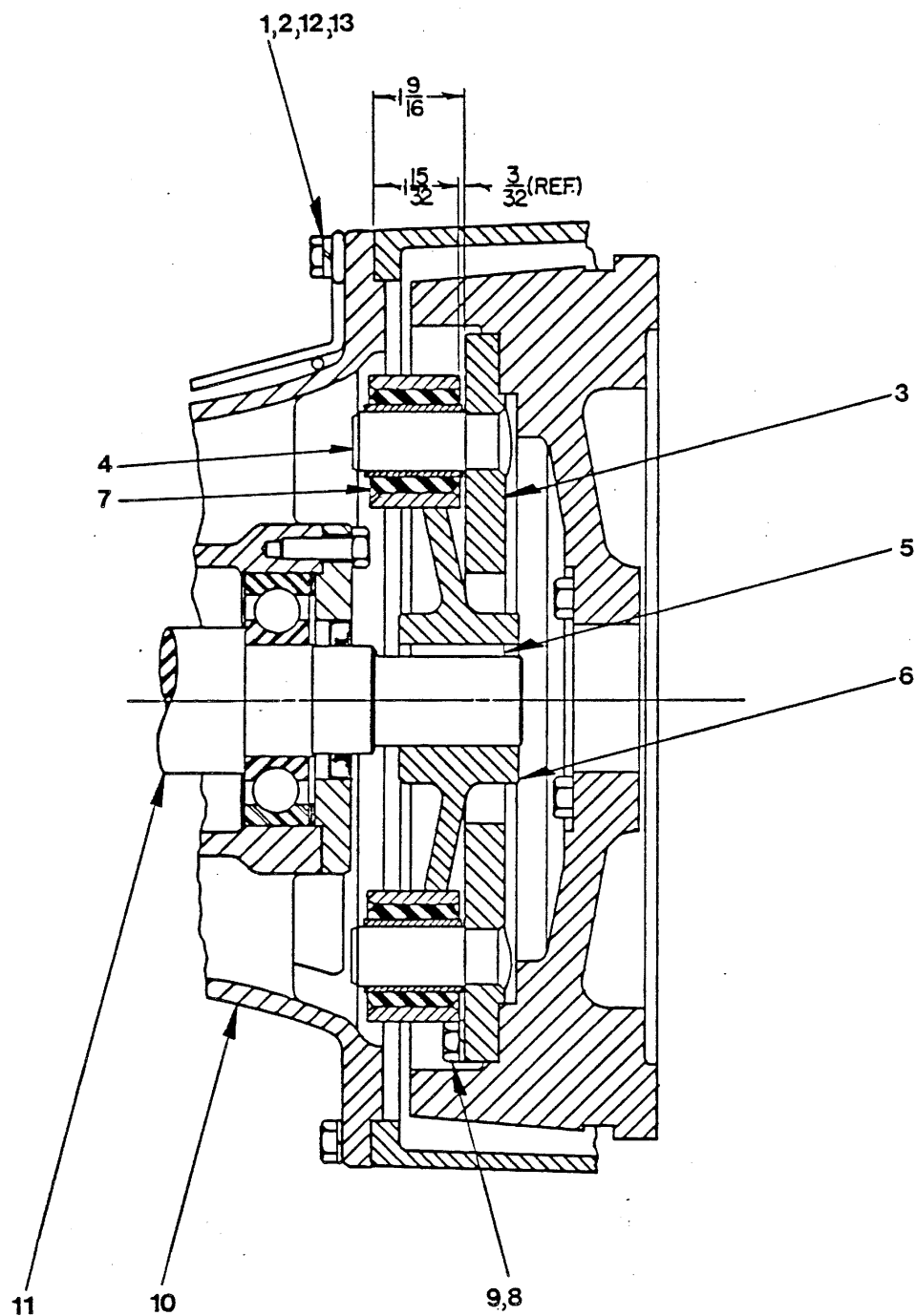

Figure 3. Drive Assembly For 16C2-F4L

PARTS LIST
Drive Assembly For 16C2-F4L

ITEM NO.	PART NAME	PART NUMBER	MATL CODE	QTY
1	HEX HD CAPSCREW	22645-164	-----	12
2	LOCKWASHER	21171-511	-----	12
3	DRIVE PLATE ASSEMBLY	44131-005	24150	1
4	* -DRIVE PIN	13819	15030	2
5	* SHAFT KEY	N0607	15990	1
6	DRIVE ARM ASSEMBLY	13817-D	-----	1
7	* -DYNA FLEX JOINT	S2110	-----	2
8	HEX HD CAPSCREW	22645-164	-----	8
9	LOCKWASHER	21171-511	-----	8
10	INTERMEDIATE	38263-614	10010	REF
11	* IMPELLER SHAFT	38514-807	16040	REF
12	INTERMEDIATE GUARD	42381-031	24150	1
13	INTERMEDIATE GUARD	42381-032	24150	1

*INDICATES PARTS RECOMMENDED FOR STOCK

PUMP AND SEAL DISASSEMBLY AND REASSEMBLY

This pump requires little service due to its rugged, minimum-maintenance design. However, if it becomes necessary to inspect or replace the wearing parts, follow these instructions which are keyed to the sectional view(s) (see Figures 1, 2 and 3) and the accompanying parts list(s).

Most service functions, such as wear plate, impeller, and seal replacement, may be performed by draining the pump and removing the back cover assembly. However, the following instructions assume complete disassembly is required.

Before attempting to service the pump, switch off the engine ignition and remove the key to ensure that the engine will remain inoperative and close all valves in the suction and discharge lines.

For engine disassembly and repair, consult the literature supplied with the engine, or contact your local Deutz engine representative.

WARNING

```

////////////////////////////////////
//
// Before attempting to open or service the pump:
//
// 1. Familiarize yourself with this manual.
// 2. Switch off the engine ignition and remove the key
//    to ensure that the pump will remain inoperative.
// 3. Allow the pump to cool if overheated.
// 4. Vent the pump slowly and cautiously.
// 5. Close the suction and discharge valves.
// 6. Check the temperature before opening any covers,
//    plates, or plugs.
// 7. Drain the pump.
//
////////////////////////////////////

```

WARNING

```

////////////////////////////////////
//
// Use lifting and moving equipment in good repair and with
// adequate capacity to prevent injuries to personnel or
// damage to equipment. The bail is intended for use in
// lifting the pump assembly only. Suction and discharge
// hoses and piping MUST be removed from the pump when
// lifting the pump by the bail.
//
////////////////////////////////////

```

Back Cover Removal

(Figure 2)

The wear plate (32) and check valve assembly (53) are easily accessible and may be serviced by removing the back cover assembly (35). Before removing the assembly, remove the casing drain plug (41) and drain the pump. Clean and reinstall the drain plug.

Loosen the cover clamp screw (42) and clamp bar (43) securing the back cover. Pull the back cover and assembled wear plate from the pump casing (1). Remove the back cover gasket (40).

Inspect the wear plate and replace it if badly scored or worn. To remove the wear plate, disengage the hardware (33 and 34).

Suction Check Valve Removal

(Figure 2)

After the back cover assembly has been removed, reach through the opening and hold the check valve assembly (53) in place while removing the check valve pin (52). Slide the assembly out of the check valve seat (49) and remove it.

NOTE

Further disassembly of the check valve is not required since it must be replaced as a complete unit. Individual parts are not sold separately.

The check valve assembly may also be serviced by removing the suction flange (51). To remove the flange, disengage the hardware (46 and 47) and separate the suction flange from the check valve seat (49). Remove the machine screws (50) and pull the seat and assembled check valve from the suction port. Remove the check valve pin (52), and pull the check valve out of the seat.

Replace the flange gaskets (45 and 65) as required.

Pump Casing Removal

(Figure 1)

To service the impeller or seal assembly, disconnect the suction and discharge piping. Remove the hardware (52, 53 and 54) securing the pump casing to the base (51).

(Figure 2)

Remove the nuts (11) securing the pump casing to the seal plate (31) and intermediate (26). Install a standard 5/8-11 UNC lifting eye in the tapped hole in the top of the pump casing. **Be sure** to screw the eye into the casing until fully engaged. Use a hoist and sling of suitable capacity to separate the pump casing from the seal plate and intermediate.

WARNING

```

////////////////////////////////////
//
// Do not attempt to lift the complete pump unit using the //
// lifting eye. It is designed to facilitate removal or //
// installation of individual components only. Additional //
// weight may result in damage to the pump or failure of //
// the eye bolt. //
// //
////////////////////////////////////

```

Remove any leveling shims used under the casing mounting feet. Tie and tag the shims for ease of reassembly.

Impeller Removal

(Figure 2)

Turn the cross arm on the automatic lubricating grease cup (12) clockwise until it rests against the cover (see Figure 5). This will prevent the grease from escaping when the impeller is removed.

To loosen the impeller (2), tap the vanes in a counterclockwise direction (when facing impeller) with a block of wood or a soft-faced mallet. Unscrew the impeller and replace it if cracked or badly worn. Use caution when removing the impeller; tension on the seal spring will be released as the impeller is unscrewed.

Slide the impeller adjusting shims (30) off the impeller shaft (68). For ease of reassembly, tie and tag the shims, or measure and record their thickness.

Seal Removal

(Figure 2)

To remove the seal assembly (3), remove the grease cup and piping (12, 13 and 14), and slide the seal plate (31) and seal parts off the shaft as a single unit. **Be careful** not to drop or damage any seal parts.

Carefully remove the stationary and rotating seal elements, packing rings, seal spring, and shaft sleeve from the seal plate.

NOTE

The seal assembly may be removed without completely disassembling the pump by removing the impeller through the back cover opening and using a stiff wire with a hooked end to pull the seal parts out of the seal plate.

Inspect the seal liner (29) for wear or grooves which could cause leakage or damage to the seal packing rings. The seal liner is a press fit in the seal

plate (31), and does not normally require replacement. If replacement is necessary, see **Seal Installation**.

If no further disassembly is required, see **Seal Installation**.

Separating Intermediate And Drive Assembly From Engine

(Figure 3)

If it is necessary to separate the intermediate and drive assemblies from the engine, support the intermediate using a hoist and sling, and remove the hardware (1, 2, 13 and 14) securing the intermediate (15) to the engine bellhousing. Separate the assemblies by pulling the intermediate straight away from the engine.

As the assemblies are separated, the drive pins (6) will disengage from the drive arm assembly (8). The drive arm assembly and the impeller shaft key (7) are a tight press fit on the shaft (16), and will remain on the shaft.

It is not necessary to remove the drive plate assembly (5) from the engine flywheel unless the drive pins are bent or worn and must be replaced. To remove the drive plate assembly, remove the hardware (11 and 12) and remove the drive plate.

The drive pins are secured into the drive plate by a tight press fit and peening. To remove the pins, drill through from the peened end and drive the pins out using a drift pin.

Use a bearing puller to remove the drive arm assembly from the impeller shaft. Remove the shaft key.

Inspect the dyna flex joints (9), and replace them if worn. The dyna flex joints are a press fit in the drive arm.

Shaft And Bearing Removal And Disassembly

(Figure 2)

When the pump is properly operated and maintained, the intermediate should not require disassembly. Disassemble the shaft and bearings **only** when there is evidence of wear or damage.

CAUTION

Shaft and bearing disassembly in the field is not recommended. These operations should be performed only in a properly-equipped shop by qualified personnel.

Drain the bearing lubricant by removing the intermediate drain plug (27). Clean and reinstall the drain plug.

Disengage the capscrews (19), and remove the bearing cap (24), gasket (18), outboard oil seal (23), and wavy washer (25). Press the oil seal from the bearing cap.

Place a block of wood against the impeller end of the shaft (68), and tap the shaft and assembled bearings out of the intermediate. Press the inboard oil seal (28) from the intermediate.

Use a bearing puller to remove the inboard and outboard bearings (16 and 17) from the impeller shaft.

Shaft and Bearing Reassembly And Installation

(Figure 2)

Clean the intermediate, shaft and all component parts (except the bearings) with a soft cloth soaked in cleaning solvent. Inspect the parts for wear or damage and replace as necessary.

WARNING

```

////////////////////////////////////
//                               //
// Most cleaning solvents are toxic and flammable. Use //
// them only in a well-ventilated area free from excessive //
// heat, sparks, and flame. Read and follow all prec- //
// autions printed on solvent containers.                //
//                               //
////////////////////////////////////

```

Inspect the shaft for distortion, nicks or scratches or thread damage on the impeller end. Dress small nicks and burrs with a fine file or emery cloth. Replace the shaft if defective.

Clean the bearings thoroughly in **fresh** cleaning solvent. Dry the bearings with filtered compressed air and coat with light oil.

Rotate the bearings by hand to check for roughness or binding and inspect the bearing balls. If rotation is rough or the bearing balls are discolored, replace the bearings.

CAUTION

Bearings must be kept free of all dirt and foreign material. Failure to do so will greatly shorten bearing life. **DO NOT** spin dry bearings. This may scratch the balls or races and cause premature bearing failure.

The bearing tolerances provide a tight press fit onto the shaft and a snug slip fit into the intermediate. Replace the shaft or intermediate if the proper bearing fit is not achieved.

Dip the bearings in clean oil and then position them on the shaft. The loading groove on the inboard bearing **must** face toward the impeller. Use an arbor (or

hydraulic) press to press against the inner races until the bearings seat squarely against the shaft shoulders.

CAUTION

When installing the bearings onto the shaft, NEVER press or hit against the outer race, balls, or ball cage. Press ONLY on the inner race.

Apply a light coating of oil to the lip of the inboard oil seal (28), and press it into the intermediate with the lip positioned as shown in Figure 2.

Slide the shaft and assembled bearings into the intermediate bore until the inboard bearing (16) bottoms against the bore shoulder. Be careful not to damage the oil seal lip on the shaft threads.

CAUTION

When installing the shaft and bearings into the bearing bore, push against the outer race. NEVER hit the balls or ball cage.

Apply a light coating of oil to the lip of the outboard oil seal (23), and press it into the bearing cap (24) with the lip positioned as shown in Figure 2. The face of the oil seal should be just flush with the outer face of the bearing cap.

Install the wavy washer (25) and bearing cap gasket (18), then secure the bearing cap to the intermediate with the capscrews (19). Be careful not to damage the oil seal lip on the shaft keyway.

Lubricate the bearings as indicated in LUBRICATION at the end of this section.

Securing Intermediate And Drive Assembly To Engine**(Figure 3)**

If the drive pins (6) were removed from the drive plate assembly (5), install new pins by pressing them into the drive plate and peening the ends. Secure the drive plate assembly to the engine flywheel with the hardware (11 and 12).

Install the impeller shaft key (7) and press the drive arm assembly (8) onto the impeller shaft.

CAUTION

Make certain that the drive plate and drive arm assemblies are mounted in accordance with the dimensions shown in Figure 3. THESE DIMENSIONS ARE CRITICAL. If the drive arm assembly is not properly positioned on the shaft, a preload condition can cause premature bearing failure.

The end of the shaft must be recessed in the bore of the drive arm 0.03 inch. This will allow a clearance of approximately 3/32 inch between the drive arm assembly and the drive plate after the intermediate is installed on the engine bellhousing.

Align the drive arm assembly so that the drive pins will engage the dyna flex joints, and secure the intermediate (15) and guards (3 and 4) to the engine bellhousing with the hardware (1, 2, 13 and 14).

Seal Installation

(Figures 2 and 4)

Clean the seal cavity and shaft with a cloth soaked in fresh cleaning solvent.

WARNING

```

////////////////////////////////////
//
// Most cleaning solvents are toxic and flammable. Use //
// them only in a well-ventilated area free from excessive //
// heat, sparks, and flame. Read and follow all prec- //
// autions printed on solvent containers. //
// //
////////////////////////////////////

```

The seal is not normally reused because wear patterns on the finished faces cannot be realigned during reassembly. This could result in premature failure. If necessary to reuse an old seal in an emergency, **carefully** wash all metallic parts in fresh cleaning solvent and allow to dry thoroughly.

Handle the seal parts with extreme care to prevent damage. Be careful not to contaminate precision finished faces; even fingerprints on the faces can shorten seal life. If necessary, clean the faces with a non-oil based solvent and a clean lint free tissue. Wipe **lightly** in a concentric pattern to avoid scratching the faces.

Inspect the seal components for wear, scoring, grooves, and other damage that might cause leakage. Clean and polish the seal spacer sleeve, or replace it if there are nicks or cuts on either end. If any components are worn, replace the complete seal; **never mix old and new seal parts.**

If a replacement seal is being used, remove it from the container and inspect the precision finished faces to ensure that they are free of any foreign matter.

To ease installation of the seal, lubricate the packing rings and seal liner with water or a very small amount of oil, and apply a drop of light lubricating oil on the finished faces. Assemble the seal as follows, (see Figure 4).

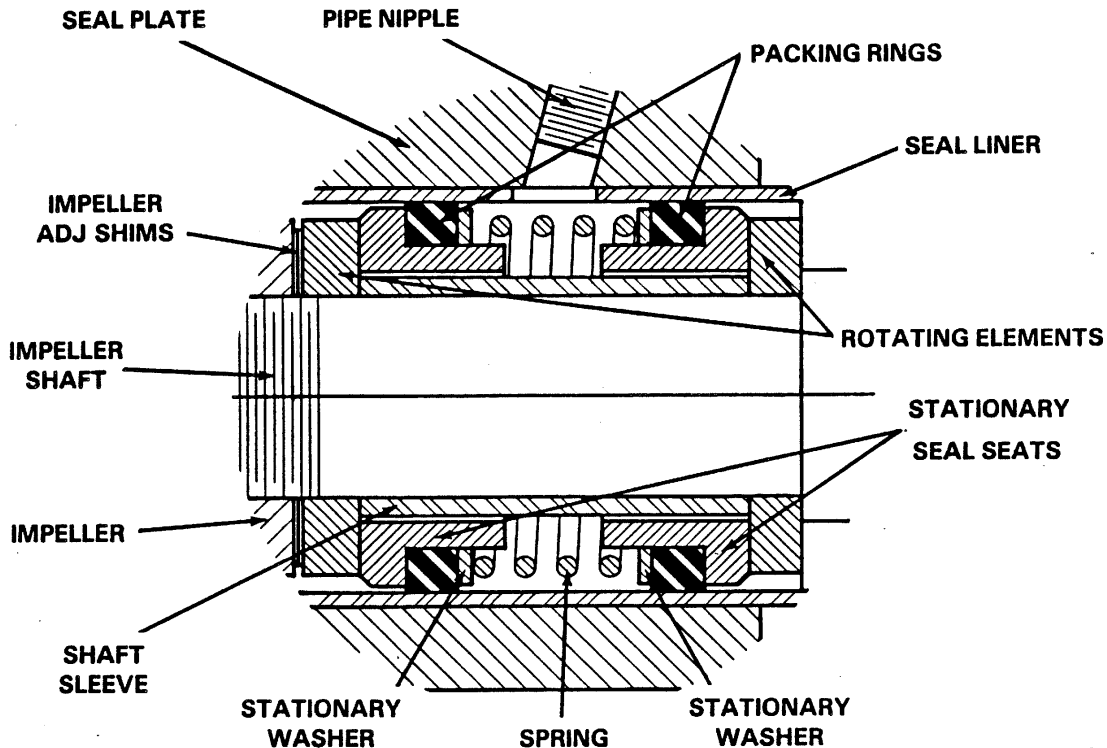

Figure 4. GS1500 Seal Assembly

CAUTION

This seal is not designed for operation at temperatures above 110°F. Do not use at higher operating temperatures.

Inspect the seal plate, the seal liner, and the impeller shaft for burrs or sharp corners, and remove any that exist. Replace the seal liner (29) if wear or grooves exist which could cause leakage or damage to the seal packing rings. To replace the seal liner, position the seal plate (31) on the bed of an arbor (or hydraulic) press and use a new sleeve to force the old one out. After the new liner is properly installed, a 1/4 inch diameter hole must be drilled through it to permit the flow of lubricant to the seal assembly. **Be careful** to center the drill in the threaded grease pipe hole and not damage the threads. Deburr the hole from the inside of the seal liner after drilling.

Slide the seal plate onto the shaft until fully seated against the intermediate. Align the threaded seal lubricant hole with the intermediate opening and tempo-

rarily secure the seal plate to the intermediate with two capscrews and nuts (1/2 UNC X 1 1/2 inch long, not supplied).

Install the inboard rotating element with the chamfered side facing the shaft shoulder.

Subassemble the stationary seal seats, packing rings, stationary washers and spring onto the shaft sleeve. Apply a drop of light oil on the precision finished faces of the stationary seats; **never use grease**. Slide the entire subassembly into the lubricated seal liner until it bottoms against the inboard rotating element.

Install the outboard rotating element with the chamfered side facing the impeller.

Reinstall the automatic grease cup and piping (12, 13, and 14).

Lubricate the seal as indicated in LUBRICATION, after the impeller has been installed.

Impeller Installation And Adjustment

(Figure 2)

Inspect the impeller, and replace it if cracked or badly worn.

Slide the same thickness of impeller adjusting shims (30) as previously removed onto the shaft and screw the impeller on until tight.

A clearance of .025 to .045 inch between the impeller and the seal plate is necessary for maximum pump efficiency. Measure this clearance, and add or remove impeller shims until it is reached.

Remove the two capscrews temporarily holding the seal plate and install the same thickness of casing gaskets (9) as previously removed. Secure the seal plate and pump casing to the intermediate with the nuts (11). **Do not** fully tighten the nuts (11) until the impeller face clearance has been set.

A clearance of .010 to .020 inch between the impeller and the wear plate is also recommended for maximum pump efficiency. This clearance must be set after installing the back cover, by adding or removing gaskets in the pump casing gasket set (9) until the impeller binds against the wear plate when the shaft is turned. After the impeller binds, add .015 inch of gaskets.

NOTE

An alternate method of adjusting this clearance is to reach through the discharge port with a feeler gauge and measure the gap. Add or subtract pump casing gaskets accordingly.

Remove the lifting eye from the pump casing.

Suction Check Valve Installation

Inspect the check valve assembly, and replace it if badly worn.

NOTE

The check valve assembly must be replaced as a complete unit. Individual parts are not sold separately.

Reach through the back cover opening with the assembled check valve and position the check valve adaptor into the mounting slot in the seat. Align the adaptor with the seat hole and secure the assembly with the check valve pin (52).

NOTE

If the suction flange or check valve seat was removed, replace the respective gaskets and apply 'Permatex Aviation No. 3 Form-A-Gasket' or equivalent to the mating surfaces.

Back Cover Installation

(Figure 2)

If the wear plate (51) was removed for replacement, carefully center it on the back cover and secure it with the hardware (33 and 34). The wear plate must be concentric to prevent binding when the back cover is installed.

Clean any scale or debris from the contacting surfaces in the pump casing that might prevent a good seal with the back cover. Replace the back cover gasket (40) and slide the back cover assembly into the pump casing. Be sure the wear plate does not bind against the impeller.

NOTE

To ease future disassembly, apply a film of grease or 'Never-Seez' on the back cover shoulder, or any surface which contacts the pump casing. This action will reduce rust and scale build-up.

Secure the back cover assembly by installing the clamp bar (43) and tightening the cover clamp screw (42). **Do not** over-tighten the clamp screw; it should be just tight enough to ensure a good seal at the back cover shoulder.

Final Pump Reassembly

(Figure 1)

Install any leveling shims used under the pump casing mounting feet and secure the casing to the base (51) with the hardware (52, 53 and 54). **Be sure** the pump is secured to the base and engine.

Install the suction and discharge lines, and open all valves. Make certain that all piping connections are tight, properly supported and secure.

Be sure the pump end and engine have been properly lubricated, see LUBRICATION.

Fill the pump casing with clean liquid. Reinstall the fill cover plate and tighten it.

Refer to OPERATION, Section C, and start the pump.

LUBRICATION

Seal Assembly

(Figure 2)

Fill the grease cup (12) through the grease fitting with No. 2 lithium base grease until grease escapes from the relief hole. Turn the grease cup arm counterclockwise until it is at the top of the stem; this will release the spring to apply grease to the seal (see Figure 5).

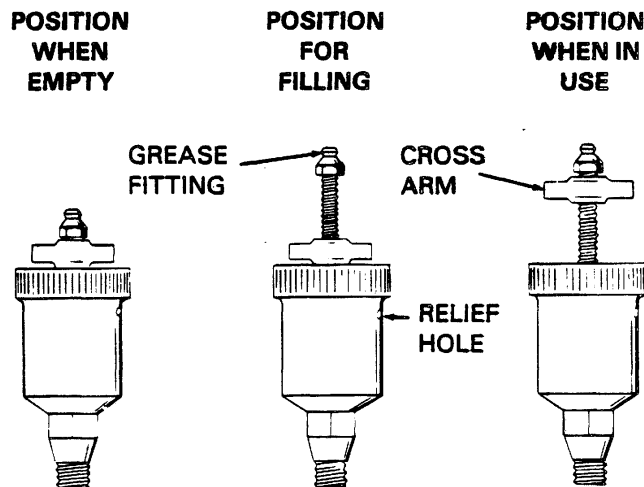

Figure 5. Automatic Lubricating Grease Cup

Bearings

(Figure 2)

The intermediate was fully lubricated when shipped from the factory. Check the oil level regularly through the sight gauge (20) and maintain it at the mid-point of the gauge. When lubrication is required, add SAE No. 30

non-detergent oil through the oil hole cover (15). **Do not** over lubricate. Over-lubrication can cause the bearings to over-heat, resulting in premature bearing failure.

Under normal conditions, drain the intermediate once each year and refill with approximately 7 1/2 ounces of clean oil. Change the oil more frequently if the pump is operated continuously or installed in an environment with rapid temperature change.

CAUTION

Monitor the condition of the bearing lubricant regularly for evidence of rust or moisture condensation. This is especially important in areas where variable hot and cold temperatures are common.

For cold weather operation, consult the factory or a lubricant supplier for the recommended grade of oil.

Engine

Consult the literature supplied with the engine, or contact your local Deutz engine representative.

**For U.S. and International Warranty Information,
Please Visit www.grpumps.com/warranty**

or call:

U.S.: 419-755-1280

International: +1-419-755-1352

**For Canadian Warranty Information,
Please Visit www.grcanada.com/warranty**

or call:

519-631-2870

THE GORMAN-RUPP COMPANY • MANSFIELD, OHIO

GORMAN-RUPP OF CANADA LIMITED • ST. THOMAS, ONTARIO, CANADA