

---

# INSTALLATION, OPERATION, AND MAINTENANCE MANUAL

WITH PARTS LIST



10-SERIES PUMP

MODEL
<b>16C20-F4L</b>

**THE GORMAN-RUPP COMPANY • MANSFIELD, OHIO**

GORMAN-RUPP OF CANADA LIMITED • ST. THOMAS, ONTARIO, CANADA

Printed in U.S.A.

©Copyright by the Gorman-Rupp Company 1989



# TABLE OF CONTENTS

<b>INTRODUCTION</b> .....	<b>PAGE I – 1</b>
<b>WARNINGS – SECTION A</b> .....	<b>PAGE A – 1</b>
<b>INSTALLATION – SECTION B</b> .....	<b>PAGE B – 1</b>
Pump Dimensions .....	PAGE B – 1
PREINSTALLATION INSPECTION .....	PAGE B – 2
Battery Specifications And Installation .....	PAGE B – 2
POSITIONING PUMP .....	PAGE B – 2
Lifting .....	PAGE B – 2
Mounting .....	PAGE B – 2
SUCTION AND DISCHARGE PIPING .....	PAGE B – 3
Materials .....	PAGE B – 3
Line Configuration .....	PAGE B – 3
Connections to Pump .....	PAGE B – 3
Gauges .....	PAGE B – 3
SUCTION LINES .....	PAGE B – 3
Fittings .....	PAGE B – 3
Strainers .....	PAGE B – 3
Sealing .....	PAGE B – 4
Suction Lines In Sumps .....	PAGE B – 4
Suction Line Positioning .....	PAGE B – 4
DISCHARGE LINES .....	PAGE B – 5
Siphoning .....	PAGE B – 5
Valves .....	PAGE B – 5
Bypass Lines .....	PAGE B – 5
ALIGNMENT .....	PAGE B – 5
<b>OPERATION – SECTION C</b> .....	<b>PAGE C – 1</b>
PRIMING .....	PAGE C – 1
STARTING .....	PAGE C – 1
OPERATION .....	PAGE C – 1
Lines With a Bypass .....	PAGE C – 1
Lines Without a Bypass .....	PAGE C – 2
Leakage .....	PAGE C – 2
Liquid Temperature And Overheating .....	PAGE C – 2
Strainer Check .....	PAGE C – 2
Pump Vacuum Check .....	PAGE C – 2
STOPPING .....	PAGE C – 3
Cold Weather Preservation .....	PAGE C – 3
BEARING TEMPERATURE CHECK .....	PAGE C – 3
<b>TROUBLESHOOTING – SECTION D</b> .....	<b>PAGE D – 1</b>
<b>PUMP MAINTENANCE AND REPAIR – SECTION E</b> .....	<b>PAGE E – 1</b>
PERFORMANCE CURVE FOR PUMP MODEL 16C20–F4L .....	PAGE E – 1
PARTS LIST – PUMP MODEL 16C20–F4L .....	PAGE E – 3

**TABLE OF CONTENTS**  
**(continued)**

PARTS LIST – PUMP END ASSY 16C20–(F4L) .....	PAGE E – 5
PARTS LIST – DRIVE ASSEMBLY FOR 16C20–F4L .....	PAGE E – 7
PUMP AND SEAL DISASSEMBLY AND REASSEMBLY .....	PAGE E – 8
Back Cover Removal .....	PAGE E – 8
Suction Check Valve Removal .....	PAGE E – 8
Pump Casing Removal .....	PAGE E – 9
Impeller Removal .....	PAGE E – 9
Seal Removal and Disassembly .....	PAGE E – 9
Separating Intermediate And Drive Assembly From engine .....	PAGE E – 9
Shaft and Bearing Removal and Disassembly .....	PAGE E – 10
Shaft and Bearing Reassembly and Installation .....	PAGE E – 11
Securing Intermediate And Drive Assembly To Engine .....	PAGE E – 12
Seal Reassembly and Installation .....	PAGE E – 12
Impeller Installation And Adjustment .....	PAGE E – 14
Suction Check Valve Installation .....	PAGE E – 14
Back Cover Installation .....	PAGE E – 15
Final Pump Assembly .....	PAGE E – 15
LUBRICATION .....	PAGE E – 15
Seal Assembly .....	PAGE E – 15
Bearings .....	PAGE E – 15
Engine .....	PAGE E – 16

## INTRODUCTION

This Installation, Operation, and Maintenance manual is designed to help you achieve the best performance and longest life from your Gorman-Rupp pump.

This pump is a 10 Series, semi-open impeller, self-priming centrifugal model with a suction

check valve. The pump is powered by a Deutz Diesel engine, model F4L-912D. The pump is designed for handling dirty water containing specified entrained solids. The basic material of construction for wetted parts is gray iron, with ductile iron impeller and steel wearing parts.

If there are any questions regarding the pump or its application which are not covered in this manual or in other literature accompanying this unit, please contact your Gorman-Rupp distributor, or write:

**The Gorman-Rupp Company**  
P.O. Box 1217  
Mansfield, Ohio 44901-1217

or

**Gorman-Rupp of Canada Limited**  
70 Burwell Road  
St. Thomas, Ontario N5P 3R7

For information or technical assistance on the engine, contact the engine manufacturer's local dealer or representative.

The following are used to alert maintenance personnel to procedures which require special attention, to those which could damage equipment, and to those which could be dangerous to personnel:

### NOTE

*Instructions to aid in installation, operation, and maintenance or which clarify a procedure.*

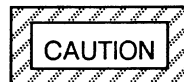

INSTRUCTIONS WHICH MUST BE FOLLOWED TO AVOID CAUSING DAMAGE TO THE PRODUCT OR OTHER EQUIPMENT INCIDENTAL TO THE INSTALLATION. THESE INSTRUCTIONS DESCRIBE THE REQUIREMENTS AND THE POSSIBLE DAMAGE WHICH COULD RESULT FROM FAILURE TO FOLLOW THE PROCEDURES.



THESE INSTRUCTIONS MUST BE FOLLOWED TO AVOID CAUSING INJURY OR DEATH TO PERSONNEL, AND DESCRIBE THE PROCEDURE REQUIRED AND THE INJURY WHICH COULD RESULT FROM FAILURE TO FOLLOW THE PROCEDURE.



## WARNINGS – SECTION A

THESE WARNINGS APPLY TO 10 SERIES ENGINE DRIVEN PUMPS. REFER TO THE MANUAL ACCOMPANYING THE ENGINE BEFORE ATTEMPTING TO BEGIN OPERATION.



BEFORE ATTEMPTING TO OPEN OR SERVICE THE PUMP:

1. FAMILIARIZE YOURSELF WITH THIS MANUAL.
2. SWITCH OFF THE ENGINE IGNITION AND REMOVE THE KEY TO ENSURE THAT THE PUMP WILL REMAIN INOPERATIVE.
3. ALLOW THE PUMP TO COOL IF OVERHEATED.
4. CHECK THE TEMPERATURE BEFORE OPENING ANY COVERS, PLATES, OR PLUGS.
5. CLOSE THE SUCTION AND DISCHARGE VALVES.
6. VENT THE PUMP SLOWLY AND CAUTIOUSLY.
7. DRAIN THE PUMP.



THIS PUMP IS DESIGNED TO HANDLE DIRTY WATER CONTAINING SPECIFIED ENTRAINED SOLIDS. DO NOT ATTEMPT TO PUMP VOLATILE, CORROSIVE, OR FLAMMABLE MATERIALS, OR ANY LIQUIDS WHICH MAY DAMAGE THE PUMP OR ENDANGER PERSONNEL AS A RESULT OF PUMP FAILURE.

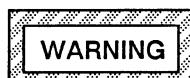

USE LIFTING AND MOVING EQUIPMENT IN GOOD REPAIR AND WITH ADEQUATE CAPACITY TO PREVENT INJURIES TO PERSONNEL OR DAMAGE TO EQUIPMENT. THE BAIL IS INTENDED FOR USE IN LIFTING THE PUMP ASSEMBLY ONLY. SUCTION AND DISCHARGE

HOSES AND PIPING MUST BE REMOVED FROM THE PUMP BEFORE LIFTING.



AFTER THE PUMP HAS BEEN POSITIONED, MAKE CERTAIN THAT THE PUMP AND ALL PIPING OR HOSE CONNECTIONS ARE TIGHT, PROPERLY SUPPORTED AND SECURE BEFORE OPERATION.



DO NOT OPERATE THE PUMP AGAINST A CLOSED DISCHARGE VALVE FOR LONG PERIODS OF TIME. IF OPERATED AGAINST A CLOSED DISCHARGE VALVE, PUMP COMPONENTS WILL DETERIORATE, AND THE LIQUID COULD COME TO A BOIL, BUILD PRESSURE, AND CAUSE THE PUMP CASING TO RUPTURE OR EXPLODE.



DO NOT REMOVE PLATES, COVERS, GAUGES, PIPE PLUGS, OR FITTINGS FROM AN OVERHEATED PUMP. VAPOR PRESSURE WITHIN THE PUMP CAN CAUSE PARTS BEING DISENGAGED TO BE EJECTED WITH GREAT FORCE. ALLOW THE PUMP TO COOL BEFORE SERVICING.



DO NOT OPERATE AN INTERNAL COMBUSTION ENGINE IN AN EXPLOSIVE ATMOSPHERE. WHEN OPERATING INTERNAL COMBUSTION ENGINES IN AN ENCLOSED AREA, MAKE CERTAIN THAT EXHAUST FUMES ARE PIPED TO THE OUTSIDE. THESE FUMES CONTAIN CARBON MONOXIDE, A DEADLY GAS

---

THAT IS COLORLESS, TASTELESS, AND ODORLESS.



FUEL USED BY INTERNAL COMBUSTION ENGINES PRESENTS AN EXTREME EXPLOSION AND FIRE HAZARD. MAKE CERTAIN THAT ALL FUEL LINES ARE SECURELY CONNECTED AND FREE OF LEAKS. NEVER REFUEL A HOT OR RUNNING ENGINE. AVOID OVERFILLING THE

FUEL TANK. ALWAYS USE THE CORRECT TYPE OF FUEL.



NEVER TAMPER WITH THE GOVERNOR TO GAIN MORE POWER. THE GOVERNOR ESTABLISHES SAFE OPERATING LIMITS THAT SHOULD NOT BE EXCEEDED. THE MAXIMUM CONTINUOUS OPERATING SPEED FOR THIS PUMP IS 1900 RPM.



## INSTALLATION – SECTION B

Review all **WARNINGS** in Section A.

Since pump installations are seldom identical, this section offers only general recommendations and practices required to inspect, position, and arrange the pump and piping.

Most of the information pertains to a standard static lift application where the pump is positioned above the free level of liquid to be pumped.

If installed in a **flooded suction application** where the liquid is supplied to the pump under pressure, some of the information such as mounting, line configuration, and priming must

be tailored to the specific application. Since the pressure supplied to the pump is critical to performance and safety, **be sure** to limit the incoming pressure to **50%** of the maximum permissible operating pressure as shown on the pump performance curve.

For further assistance, contact your Gorman-Rupp distributor or the Gorman-Rupp Company.

### Pump Dimensions

See Figure 1 for the approximate physical dimensions of this pump.

### OUTLINE DRAWING

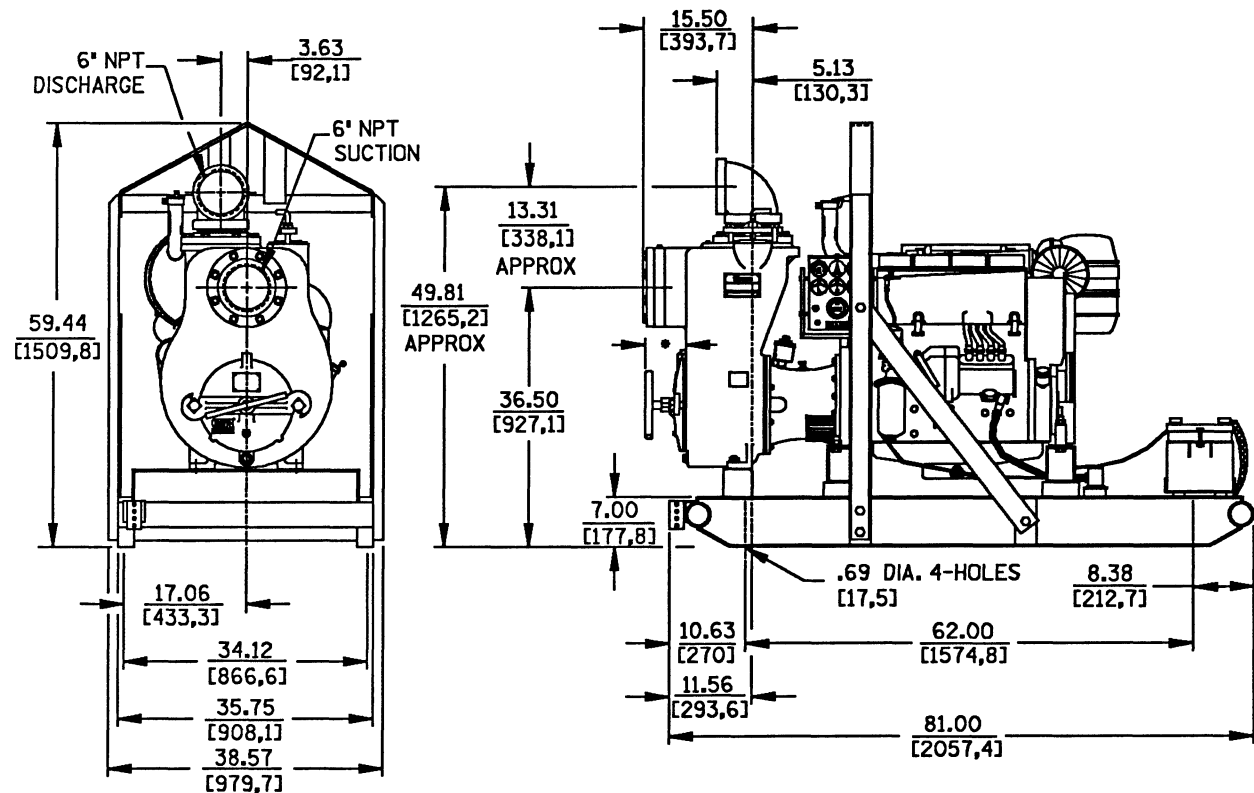

DIMENSIONS:  
INCHES  
[MILLIMETERS]

• 18.00 [457,2] REQUIRED FOR REMOVAL OF COVER PLATE.

POWERED BY DEUTZ F4L-912 DIESEL ENGINE.

Figure 1. Pump Model 16C20-F4L

## PREINSTALLATION INSPECTION

The pump assembly was inspected and tested before shipment from the factory. Before installation, inspect the pump for damage which may have occurred during shipment. Check as follows:

- a. Inspect the pump for cracks, dents, damaged threads, and other obvious damage.
- b. Check for and tighten loose attaching hardware. Since gaskets tend to shrink after drying, check for loose hardware at mating surfaces.
- c. Carefully read all tags, decals, and markings on the pump assembly, and follow the instructions indicated.
- d. Check levels and lubricate as necessary. Refer to **LUBRICATION** in the **MAINTENANCE AND REPAIR** section of this manual and perform duties as instructed.
- e. If the pump and engine have been stored for more than 12 months, some of the components or lubricants may have exceeded their maximum shelf life. These **must be inspected or replaced** to ensure maximum pump service.

If the maximum shelf life has been exceeded, or if anything appears to be abnormal, contact your Gorman-Rupp distributor or the factory to determine the repair or updating policy. **Do not** put the pump into service until appropriate action has been taken.

### Battery Specifications And Installation

Unless otherwise specified on the pump order, the engine battery was **not** included with the unit. Refer to the following specifications when selecting a battery.

**Table 1. Battery Specifications**

Voltage	Cold Crank Amps @ 0° F	Reserve Capacity @ 80° F (Minutes)	Amp/ Hr. Rating	Approx. Overall Dims. (Inches)
12 Volts	960-975	365	175	20.5L x 8.75W x 9.75H

Refer to the information accompanying the battery and/or electrolyte solution for activation and charging instructions.

Before installing the battery, clean the positive and negative cable connectors, and the battery terminals. Secure the battery by tightening the holddown brackets. The terminals and clamps may be coated with petroleum jelly to retard corrosion. Connect and tighten the positive cable first, then the negative cable.

## POSITIONING PUMP



**USE LIFTING AND MOVING EQUIPMENT IN GOOD REPAIR AND WITH ADEQUATE CAPACITY TO PREVENT INJURIES TO PERSONNEL OR DAMAGE TO EQUIPMENT. THE BAIL IS INTENDED FOR USE IN LIFTING THE PUMP ASSEMBLY ONLY. SUCTION AND DISCHARGE HOSES AND PIPING MUST BE REMOVED FROM THE PUMP BEFORE LIFTING.**

### Lifting

Use lifting equipment with a capacity of at least **12,000 pounds**. This pump weighs approximately **2,360 pounds**, not including the weight of accessories and base. Customer installed equipment such as suction and discharge piping **must** be removed before attempting to lift.

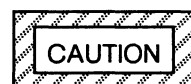

**THE PUMP ASSEMBLY CAN BE SERIOUSLY DAMAGED IF THE CABLES OR CHAINS USED TO LIFT AND MOVE THE UNIT ARE IMPROPERLY WRAPPED AROUND THE PUMP.**

### Mounting

Locate the pump in an accessible place as close as practical to the liquid being pumped. Level mounting is essential for proper operation.

If the pump has been mounted on a movable base, make certain the base is stationary by set-

ting the brake and blocking the wheels before attempting to operate the pump.

To ensure sufficient lubrication and fuel supply to the engine, **do not** position the pump and engine more than 15° off horizontal for continuous operation. The pump and engine may be positioned up to 30° off horizontal for **intermittent operation only**; however, the engine manufacturer should be consulted for continuous operation at angles greater than 15°.

## SUCTION AND DISCHARGE PIPING

Pump performance is adversely effected by increased suction lift, discharge elevation, and friction losses. See the performance curve and operating range shown on Page E-1 to be sure your overall application allows pump to operate within the safe operation range.

### Materials

Either pipe or hose may be used for suction and discharge lines; however, the materials must be compatible with the liquid being pumped. If hose is used in suction lines, it must be the rigid-wall, reinforced type to prevent collapse under suction. Using piping couplings in suction lines is not recommended.

### Line Configuration

Keep suction and discharge lines as straight as possible to minimize friction losses. Make minimum use of elbows and fittings, which substantially increase friction loss. If elbows are necessary, use the long-radius type to minimize friction loss.

### Connections to Pump

Before tightening a connecting flange, align it exactly with the pump port. Never pull a pipe line into place by tightening the flange bolts and/or couplings.

Lines near the pump must be independently supported to avoid strain on the pump which could cause excessive vibration, decreased

bearing life, and increased shaft and seal wear. If hose-type lines are used, they should have adequate support to secure them when filled with liquid and under pressure.

### Gauges

Most pumps are drilled and tapped for installing discharge pressure and vacuum suction gauges. If these gauges are desired for pumps that are not tapped, drill and tap the suction and discharge lines not less than 18 inches from the suction and discharge ports and install the lines. Installation closer to the pump may result in erratic readings.

## SUCTION LINES

To avoid air pockets which could affect pump priming, the suction line must be as short and direct as possible. When operation involves a suction lift, the line must always slope upward to the pump from the source of the liquid being pumped; if the line slopes down to the pump at any point along the suction run, air pockets will be created.

### Fittings

Suction lines should be the same size as the pump inlet. If reducers are used in suction lines, they should be the eccentric type, and should be installed with the flat part of the reducers uppermost to avoid creating air pockets. Valves are not normally used in suction lines, but if a valve is used, install it with the stem horizontal to avoid air pockets.

### Strainers

If a strainer is furnished with the pump, be certain to use it; any spherical solids which pass through a strainer furnished with the pump will also pass through the pump itself.

If a strainer is not furnished with the pump, but is installed by the pump user, make certain that the total area of the openings in the strainer is at least three or four times the cross section of the suction line, and that the openings will not permit

passage of solids larger than the solids handling capability of the pump.

This pump is designed to handle up to 3 inch diameter spherical solids.

**Sealing**

Since even a slight leak will affect priming, head, and capacity, especially when operating with a high suction lift, all connections in the suction line should be sealed with pipe dope to ensure an airtight seal. Follow the sealant manufacturer's recommendations when selecting and applying the pipe dope. The pipe dope should be compatible with the liquid being pumped.

**Suction Lines In Sumps**

If a single suction line is installed in a sump, it should be positioned away from the wall of the sump at a distance equal to 1 1/2 times the diameter of the suction line.

If there is a liquid flow from an open pipe into the sump, the flow should be kept away from the suction inlet because the inflow will carry air down into the sump, and air entering the suction line will reduce pump efficiency.

If it is necessary to position inflow close to the suction inlet, install a baffle between the inflow and the suction inlet at a distance 1 1/2 times the diameter of the suction pipe. The baffle will allow entrained air to escape from the liquid before it is drawn into the suction inlet.

If two suction lines are installed in a single sump, the flow paths may interact, reducing the efficiency of one or both pumps. To avoid this, position the suction inlets so that they are separated by a distance equal to at least 3 times the diameter of the suction pipe.

**Suction Line Positioning**

The depth of submergence of the suction line is critical to efficient pump operation. Figure 2 shows recommended minimum submergence vs. velocity.

**NOTE**

*The pipe submergence required may be reduced by installing a standard pipe increaser fitting at the end of the suction line. The larger opening size will reduce the inlet velocity. Calculate the required submergence using the following formula based on the increased opening size (area or diameter).*

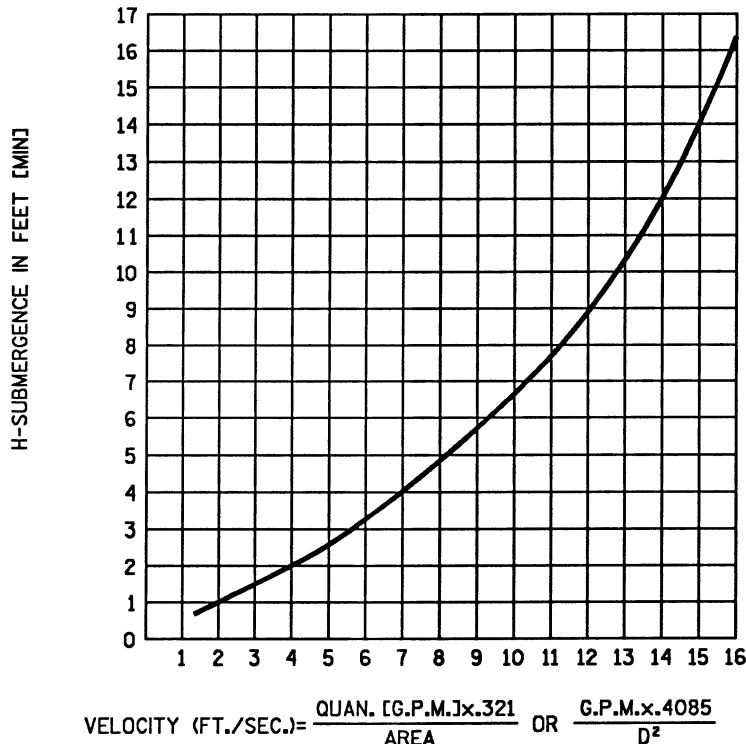

**Figure 2. Recommended Minimum Suction Line Submergence vs. Velocity**

---

## DISCHARGE LINES



### Siphoning

Do not terminate the discharge line at a level lower than that of the liquid being pumped unless a siphon breaker is used in the line. Otherwise, a siphoning action causing damage to the pump could result.

### Valves

If a throttling valve is desired in the discharge line, use a valve as large as the largest pipe to minimize friction losses. Never install a throttling valve in a suction line.

With high discharge heads, it is recommended that a throttling valve and a system check valve be installed in the discharge line to protect the pump from excessive shock pressure and reverse rotation when it is stopped.

IF THE APPLICATION INVOLVES A HIGH DISCHARGE HEAD, GRADUALLY CLOSE THE DISCHARGE THROTTLING VALVE BEFORE STOPPING THE PUMP.

### Bypass Lines

If a system check valve is used due to high discharge head, it may be necessary to vent trapped air from the top of the pump during the priming process. This may be accomplished by installing a bypass line from the top of the pump, back to the source of liquid. The end of the bypass line must be submerged. The line must be large enough to prevent clogging, but not so large as to affect pump discharge capacity.

## ALIGNMENT

The alignment of the pump and the engine is critical for trouble-free mechanical operation. See Section E, **Securing Intermediate And Drive Assembly To Engine** for detailed information.



## OPERATION – SECTION C

Review all warnings in Section A.

Follow the instructions on all tags, labels and decals attached to the pump.



THIS PUMP IS DESIGNED TO HANDLE DIRTY WATER CONTAINING SPECIFIED ENTRAINED SOLIDS. DO NOT ATTEMPT TO PUMP VOLATILE, CORROSIVE, OR FLAMMABLE MATERIALS, OR ANY LIQUIDS WHICH MAY DAMAGE THE PUMP OR ENDANGER PERSONNEL AS A RESULT OF PUMP FAILURE.



NEVER TAMPER WITH THE GOVERNOR TO GAIN MORE POWER. THE GOVERNOR ESTABLISHES SAFE OPERATING LIMITS THAT SHOULD NOT BE EXCEEDED. THE MAXIMUM CONTINUOUS OPERATING SPEED FOR THIS PUMP IS 1900 RPM.

### PRIMING

Install the pump and piping as described in **INSTALLATION**. Make sure that the piping connections are tight, and that the pump is securely mounted. Check that the pump is properly lubricated (see **LUBRICATION** in **MAINTENANCE AND REPAIR**).

This pump is self-priming, but the pump should never be operated unless there is liquid in the pump casing.

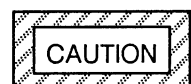

NEVER OPERATE THIS PUMP UNLESS THERE IS LIQUID IN THE PUMP CASING. THE PUMP WILL NOT PRIME WHEN DRY. EXTENDED OPERATION

OF A DRY PUMP WILL DESTROY THE SEAL ASSEMBLY.

Add liquid to the pump casing when:

1. The pump is being put into service for the first time.
2. The pump has not been used for a considerable length of time.
3. The liquid in the pump casing has evaporated.

When installed in a flooded suction application, simply open the system valves and permit the incoming liquid to evacuate the air. After the pump and piping system have completely filled, evacuate any remaining air pockets in the pump or suction line by loosening pipe plug or opening bleeder valves.

Once the pump casing has been filled, the pump will prime as necessary.

When installed in a static lift application such as fire truck filling, always leave enough liquid in the tank to prime the pump prior to start-up.

### NOTE

*This pump is self-priming; however, it is not suited for unattended reprime applications. In the event of suction check valve failure and loss of prime, the pump casing must be refilled through the fill cover or fill plug.*

### STARTING

Consult the operations manual furnished with the engine.

### OPERATION

#### Lines With a Bypass

Close the discharge throttling valve (if so equipped) so that the pump will not have to prime against the weight of the liquid in the dis-

charge line. Air from the suction line will be discharged through the bypass line back to the wet well during the priming cycle. When the pump is fully primed and liquid is flowing steadily from the bypass line, open the discharge throttling valve. Liquid will then continue to circulate through the bypass line while the pump is in operation.

### Lines Without a Bypass

Open all valves in the discharge line and start the engine. Priming is indicated by a positive reading on the discharge pressure gauge or by a quieter operation. The pump may not prime immediately because the suction line must first fill with liquid. If the pump fails to prime within five minutes, stop it and check the suction line for leaks.

After the pump has been primed, partially close the discharge line throttling valve in order to fill the line slowly and guard against excessive shock pressure which could damage pipe ends, gaskets, sprinkler heads, and any other fixtures connected to the line. When the discharge line is completely filled, adjust the throttling valve to the required flow rate.

### Leakage

No leakage should be visible at pump mating surfaces, or at pump connections or fittings. Keep all line connections and fittings tight to maintain maximum pump efficiency.

### Liquid Temperature And Overheating

The **maximum** liquid temperature for this pump is 160° F. Do not apply it at a higher operating temperature.

Overheating can occur if operated with the valves in the suction or discharge lines closed. Operating against closed valves could bring the liquid to a boil, build pressure, and cause the pump to rupture or explode. If overheating occurs, stop the pump and allow it to cool before servicing it. Refill the pump casing with cool liquid.



**ALLOW AN OVER-HEATED PUMP TO COOL BEFORE SERVICING. DO NOT REMOVE PLATES, COVERS, GAUGES, OR FITTINGS FROM AN OVER-HEATED PUMP. LIQUID WITHIN THE PUMP CAN REACH BOILING TEMPERATURES, AND VAPOR PRESSURE WITHIN THE PUMP CAN CAUSE PARTS BEING DISENGAGED TO BE EJECTED WITH GREAT FORCE. AFTER THE PUMP COOLS, DRAIN THE LIQUID FROM THE PUMP BY REMOVING THE CASING DRAIN PLUG. USE CAUTION WHEN REMOVING THE PLUG TO PREVENT INJURY TO PERSONNEL FROM HOT LIQUID.**

### Strainer Check

If a suction strainer has been shipped with the pump or installed by the user, check the strainer regularly, and clean it as necessary. The strainer should also be checked if pump flow rate begins to drop. If a vacuum suction gauge has been installed, monitor and record the readings regularly to detect strainer blockage.

**Never** introduce air or steam pressure into the pump casing or piping to remove a blockage. This could result in personal injury or damage to the equipment. If backflushing is absolutely necessary, liquid pressure **must** be limited to 50% of the maximum permissible operating pressure shown on the pump performance curve.

### Pump Vacuum Check

With the pump inoperative, install a vacuum gauge in the system, using pipe dope on the threads. Block the suction line and start the pump. At operating speed the pump should pull a vacuum of 20 inches or more of mercury. If it does not, check for air leaks in the seal, gasket, or discharge valve.

Open the suction line, and read the vacuum gauge with the pump primed and at operation speed. Shut off the pump. The vacuum gauge reading will immediately drop proportionate to static suction lift, and should then stabilize. If the vacuum reading falls off rapidly after stabiliza-



tion, an air leak exists. Before checking for the source of the leak, check the point of installation of the vacuum gauge.

## STOPPING

Never halt the flow of liquid suddenly. If the liquid being pumped is stopped abruptly, damaging shock waves can be transmitted to the pump and piping system. Close all connecting valves slowly.

On engine driven pumps, reduce the throttle speed slowly and allow the engine to idle briefly before stopping.



IF THE APPLICATION INVOLVES A HIGH DISCHARGE HEAD, GRADUALLY CLOSE THE DISCHARGE THROTTLING VALVE BEFORE STOPPING THE PUMP.

After stopping the pump, switch off the engine ignition and remove the key to ensure that the pump will remain inoperative.

### Cold Weather Preservation

In below freezing conditions, drain the pump to prevent damage from freezing. Also, clean out any solids by flushing with a hose. Operate the pump for approximately one minute; this will remove any remaining liquid that could freeze the

pump rotating parts. If the pump will be idle for more than a few hours, or if it has been pumping liquids containing a large amount of solids, drain the pump, and flush it thoroughly with clean water. To prevent large solids from clogging the drain port and preventing the pump from completely draining, insert a rod or stiff wire in the drain port, and agitate the liquid during the draining process. Clean out any remaining solids by flushing with a hose.

### BEARING TEMPERATURE CHECK

Bearings normally run at higher than ambient temperatures because of heat generated by friction. Temperatures up to 160°F are considered normal for bearings, and they can operate safely to at least 180°F.

Checking bearing temperatures by hand is inaccurate. Bearing temperatures can be measured accurately by placing a contact-type thermometer against the housing. Record this temperature for future reference.

A sudden increase in bearing temperature is a warning that the bearings are at the point of failing to operate properly. Make certain that the bearing lubricant is of the proper viscosity and at the correct level (see **LUBRICATION** in **MAINTENANCE AND REPAIR**). Bearing overheating can also be caused by shaft misalignment and/or excessive vibration.

When pumps are first started, the bearings may seem to run at temperatures above normal. Continued operation should bring the temperatures down to normal levels.



## TROUBLESHOOTING – SECTION D

Review all WARNINGS in Section A.



**BEFORE ATTEMPTING TO OPEN OR SERVICE THE PUMP:**

1. FAMILIARIZE YOURSELF WITH THIS MANUAL.
2. SWITCH OFF THE ENGINE IGNITION AND REMOVE THE KEY TO ENSURE THAT THE PUMP WILL REMAIN INOPERATIVE.
3. ALLOW THE PUMP TO COOL IF OVERHEATED.
4. CHECK THE TEMPERATURE BEFORE OPENING ANY COVERS, PLATES, OR PLUGS.
5. CLOSE THE SUCTION AND DISCHARGE VALVES.
6. VENT THE PUMP SLOWLY AND CAUTIOUSLY.
7. DRAIN THE PUMP.

TROUBLE	POSSIBLE CAUSE	PROBABLE REMEDY
PUMP FAILS TO PRIME	Not enough liquid in casing.  Suction check valve contaminated or damaged.  Air leak in suction line.  Lining of suction hose collapsed.  Leaking or worn seal or pump gasket.  Suction lift or discharge head too high.  Strainer clogged.  Suction check valve or foot valve clogged or binding.	Add liquid to casing. See <b>PRIMING</b> .  Clean or replace check valve.  Correct leak.  Replace suction hose.  Check pump vacuum. Replace leaking or worn seal or gasket.  Check piping installation and install bypass line if needed. See <b>INSTALLATION</b> .  Check strainer and clean if necessary.  Clean valve
PUMP STOPS OR FAILS TO DELIVER RATED FLOW OR PRESSURE	Air leak in suction line.  Lining of suction hose collapsed.  Leaking or worn seal or pump gasket.  Strainer clogged.	Correct leak.  Replace suction hose.  Check pump vacuum. Replace leaking or worn seal or gasket.  Check strainer and clean if necessary.

TROUBLE	POSSIBLE CAUSE	PROBABLE REMEDY
PUMP STOPS OR FAILS TO DELIVER RATED FLOW OR PRESSURE (cont.)	<p>Suction intake not submerged at proper level or sump too small.</p> <p>Impeller or other wearing parts worn or damaged.</p> <p>Impeller clogged.</p> <p>Pump speed too slow.</p> <p>Suction lift or discharge head too high.</p>	<p>Check installation and correct submergence as needed.</p> <p>Replace worn or damaged parts. Check that impeller is properly centered and rotates freely.</p> <p>Free impeller of debris.</p> <p>Check engine output; consult engine operation manual.</p> <p>Check piping installation and install bypass line if needed. See <b>INSTALLATION</b>.</p>
PUMP REQUIRES TOO MUCH POWER	<p>Pump speed too high.</p> <p>Discharge head too low.</p> <p>Liquid solution too thick.</p> <p>Bearing(s) frozen.</p>	<p>Check engine output.</p> <p>Adjust discharge valve.</p> <p>Dilute if possible.</p> <p>Disassemble pump and check bearing(s).</p>
PUMP CLOGS FREQUENTLY	<p>Liquid solution too thick.</p> <p>Discharge flow too slow.</p> <p>Suction check valve or foot valve clogged or binding.</p>	<p>Dilute if possible.</p> <p>Open discharge valve fully to increase flow rate, and run power source at maximum governed speed.</p> <p>Clean valve.</p>
EXCESSIVE NOISE	<p>Cavitation in pump.</p> <p>Pumping entrained air.</p> <p>Pump or drive not securely mounted.</p> <p>Impeller clogged or damaged.</p>	<p>Reduce suction lift and/or friction losses in suction line. Record vacuum and pressure gauge readings and consult local representative or factory.</p> <p>Locate and eliminate source of air bubble.</p> <p>Secure mounting hardware.</p> <p>Clean out debris; replace damaged parts.</p>

TROUBLE	POSSIBLE CAUSE	PROBABLE REMEDY
BEARINGS RUN TOO HOT	Bearing temperature is high, but within limits.  Low or incorrect lubricant.  Suction and discharge lines not properly supported.  Drive misaligned.	Check bearing temperature regularly to monitor any increase.  Check for proper type and level of lubricant.  Check piping installation for proper support.  Align drive properly.



## PUMP MAINTENANCE AND REPAIR – SECTION E

MAINTENANCE AND REPAIR OF THE WEARING PARTS OF THE PUMP WILL MAINTAIN PEAK OPERATING PERFORMANCE.

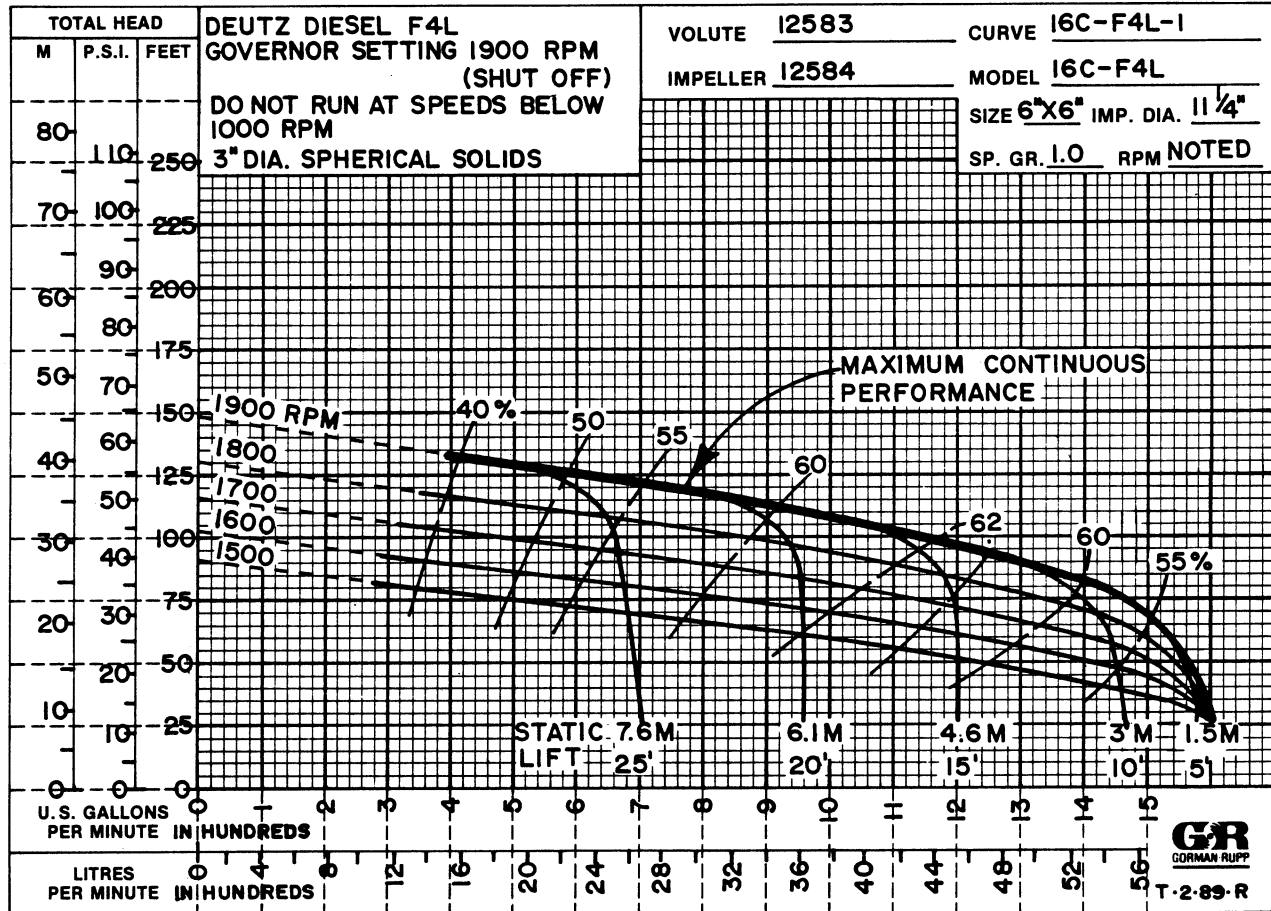

\* STANDARD PERFORMANCE FOR PUMP MODEL 16C20-F4L

\* Based on 70° F clear water at sea level with minimum suction lift. Since pump installations are seldom identical, your performance may be difference due to such factors as viscosity, specific gravity, elevation, temperature, and impeller trim.

model. Contact the Gorman-Rupp Company to verify performance or part numbers.

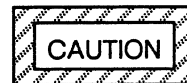

If your pump serial number is followed by an "N", your pump is NOT a standard production

PUMP SPEED AND OPERATING CONDITION POINTS MUST BE WITHIN THE CONTINUOUS PERFORMANCE RANGE SHOWN ON THE CURVE.

SECTION DRAWING

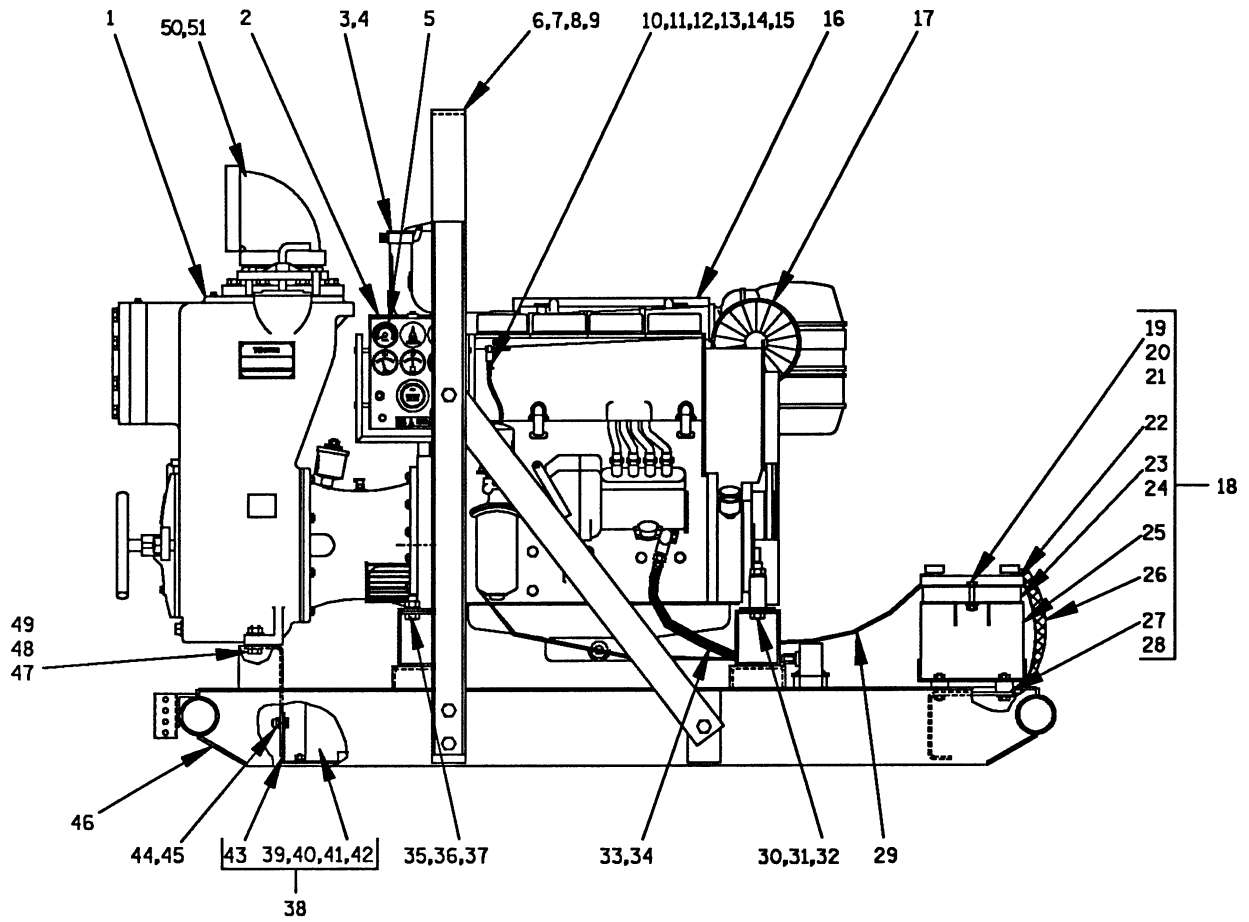

Figure 1. Model 16C20-F4L Pump Assembly



**PARTS LIST**  
**Pump Model 16C20-F4L**  
 (From S/N 913960 up)

If your pump serial number is followed by an "N", your pump is **NOT** a standard production model. Contact the Gorman-Rupp Company to verify part numbers.

ITEM NO.	PART NAME	PART NUMBER	MAT'L CODE	QTY	ITEM NO.	PART NAME	PART NUMBER	MAT'L CODE	QTY
1	PUMP END ASSY	16C20	Fig. 2	1	30	HEX HD CAPSCREW	B1017	15991	2
2	CAUTION DECAL	38816-169	-----	1	31	LOCKWASHER	J10	15991	2
3	EXHAUST ELBOW	31912-023	15990	1	32	HEX NUT	D10	15991	2
4	WEATHER CAP	S1331	-----	1	33	HOSE INLET ASSY	9072-C	-----	1
5	TACHOMETER KIT	48312-606	-----	1	34	MALE CONNECTOR	S1447	-----	1
6	HOISTING BAIL	13351-BB	24000	1	35	HEX HD CAPSCREW	B1008	15991	4
7	HEX HD CAPSCREW	B1006	15991	8	36	LOCKWASHER	J10	15991	4
8	LOCKWASHER	J10	15991	8	37	HEX NUT	D10	15991	4
9	HEX NUT	D10	15991	8	38	FUEL TANK AND GUARD ASSY	46711-041	-----	1
10	FUEL RETURN LINE	11308-F	-----	1	39	-FUEL TANK ASSY	46711-042	24150	1
11	HOSE CLAMP	26518-642	-----	2	40	-HEX NUT	D06	15991	6
12	HOSE BARB FITTING	26523-441	-----	1	41	-LOCKWASHER	J06	15991	6
13	MALE CONNECTOR	26523-402	-----	1	42	-FLAT WASHER	K06	15991	6
14	REDUCER ELBOW	Q0402	11990	1	43	-FUEL TANK GRD ASSY	42381-046	24150	1
15	FUEL RETURN LINE	14294	24030	1	44	HEX NUT W/FLANGE	21765-314	-----	10
16	MUFFLER GRD ASSY	42331-031	-----	1	45	HEX HD CAPSCREW	B0604	15991	10
17	DEUTZ F4L ENGINE	29217-043	-----	1	46	BASE ASSY	41566-659	24150	1
18	BATTERY BOX ASSY	GRP40-08C	-----	1	47	HEX HD CAPSCREW	B1010	15991	2
19	-HEX HD CAPSCREW	B0607	15991	2	48	LOCKWASHER	J10	15991	2
20	-FLAT WASHER	K06	15991	2	49	HEX NUT	D10	15991	2
21	-HEX NUT W/FLANGE	21765-314	-----	2	50	PIPE ELBOW	R96	11990	1
22 *	-GRD CABLE ASSY	47311-064	24040	1	51	PIPE NIPPLE	T96	15070	1
23	-BATT BOX LID ASSY	42113-012	24150	1		NOT SHOWN:			
24 *	-12V BATTERY	SEE OPTIONS		REF		BELT/FAN GRD KIT	48157-701	-----	1
25	-BATTERY TAG	6588-S	-----	REF		OPTIONAL:			
26	-BATTERY BOX ASSY	42431-030	24150	1		WHEEL KIT	GRP30-248-F		1
27	-STUD MOUNT	24631-002	-----	4		12V BATTERY	29331-506	-----	1
28	-HEX NUT W/FLANGE	21765-314	-----	8					
29 *	CABLE ASSY	6926-Q	24040	1					

\* INDICATES PARTS RECOMMENDED FOR STOCK

Above Serial Numbers Do Not Apply To Pumps Made In Canada.

CANADIAN SERIAL NO. .... AND UP

SECTION DRAWING

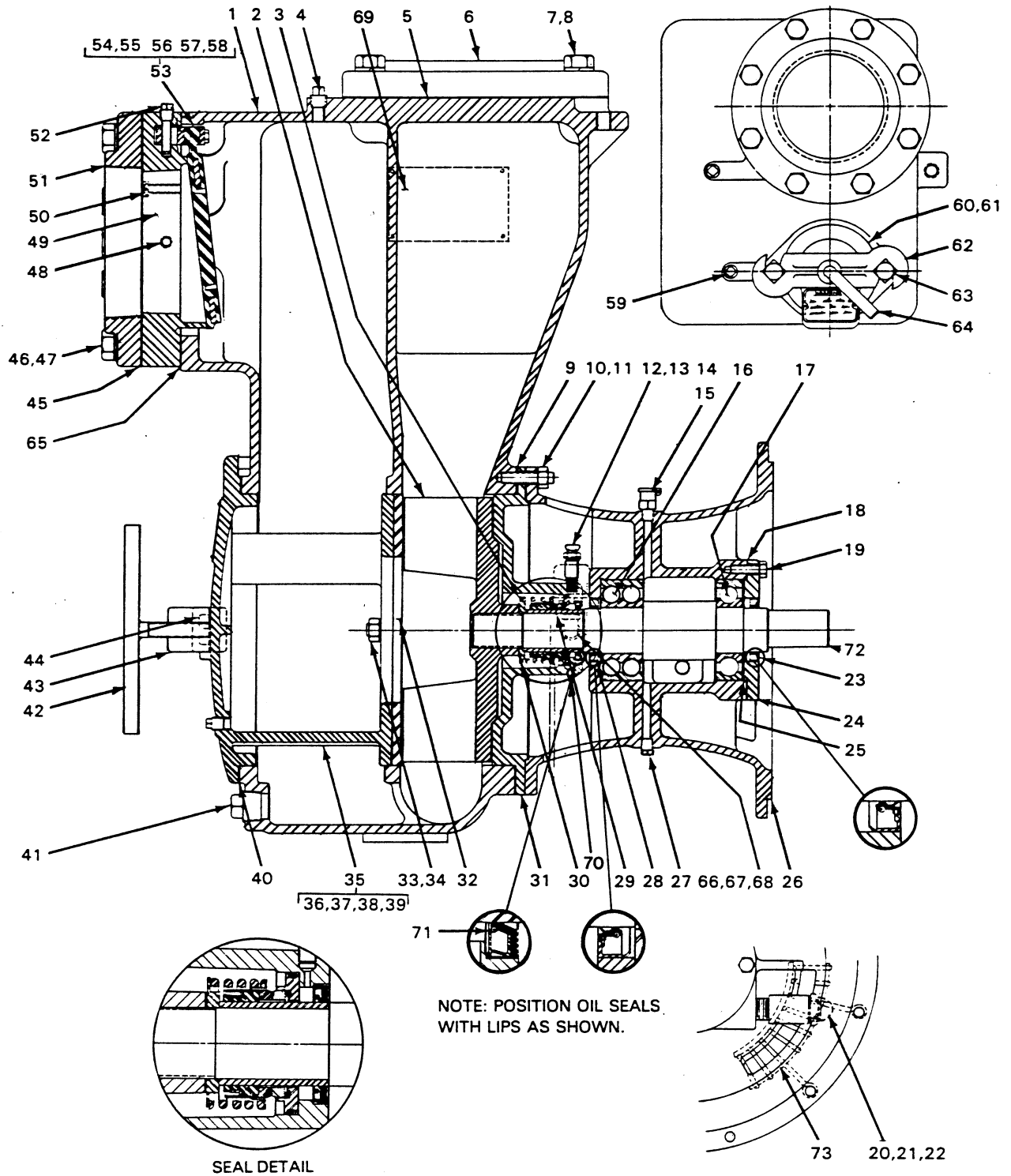

Figure 2. Pump End Assy 16C20-(F4L)

**PARTS LIST**  
**Pump End Assy 16C20-(F4L)**

ITEM NO.	PART NAME	PART NUMBER	MAT'L CODE	QTY	ITEM NO.	PART NAME	PART NUMBER	MAT'L CODE	QTY
1	PUMP CASING	12583	10010	1	42	COVER CLAMP SCREW	2536	24000	1
2 *	IMPELLER	12584	11000	1	43	COVER CLAMP BAR	12586	11000	1
3 *	SEAL ASSEMBLY	12461	-----	1	44	MACHINE BOLT	A1010	15991	2
4	PIPE PLUG	P04	11990	1	45	SUCT FLANGE GSKT	1679-G	18000	1
5 *	DISCH FLANGE GSKT	1679-G	18000	1	46	HEX HD CAPSCREW	B1214	15991	8
6	DISCHARGE FLANGE	1758	10010	1	47	LOCKWASHER	J12	15991	8
7	HEX HD CAPSCREW	B1208	15991	8	48	PIPE PLUG	P04	11990	1
8	LOCKWASHER	J12	15991	8	49 *	CHECK VALVE SEAT	11402-C	10010	1
9 *	CASING GSKT SET	34-G	18000	1	50	RD HD MACH SCREW	X0506	14990	2
10	STUD	C0809	15991	8	51	SUCTION FLANGE	1758	10010	1
11	HEX NUT	D08	15991	8	52	CHECK VALVE PIN	11645	17010	1
12 *	SEAL AIR VENT	S02162	-----	1	53 *	CHECK VALVE ASSY	46411-064	-----	1
13	PIPE COUPLING	AE02	11990	1	54	-ADAPTOR	NOT AVAILABLE		1
14	PIPE NIPPLE	T02	15070	1	55	-CHECK VALVE	NOT AVAILABLE		1
15	OIL HOLE COVER	26717-068	-----	1	56	-SPACER SLEEVE	NOT AVAILABLE		1
16 *	BALL BEARING	23421-461	-----	1	57	-BACKUP PLATE	NOT AVAILABLE		1
17 *	BALL BEARING	S1077	-----	1	58	-HEX HD CAPSCREW	NOT AVAILABLE		2
18 *	BRG CAP GSKT	5413-G	18000	1	59	PIPE PLUG	P04	11990	1
19	HEX HD CAPSCREW	B0604	15991	4	60	FILL COVER ASSY	42111-344	-----	1
20 *	OIL LEVEL SIGHT GAUGE	S1471	-----	1	61 *	FILL COVER GSKT	50-G	19210	1
21	CLOSE NIPPLE	T12	15070	1	62	COVER CLAMP BAR	38111-004	11000	1
22	PIPE COUPLING	AE12	11990	1	63	MACHINE BOLT	A1014	15991	2
23 *	OIL SEAL	25258-622	-----	1	64	COVER CLAMP SCREW	31912-009	15000	1
24	BEARING CAP	4185-A	10010	1	65 *	CHECK VALVE GSKT	11402-G	19370	1
25 *	WAVY WASHER	23963-327	-----	1	66	BOTTLE OILER	S1933	-----	1
26	INTERMEDIATE	38263-614	10010	1	67	PIPE ELBOW	R02	11990	1
27	INTERM DRAIN PLUG	P06	11990	1	68	PIPE NIPPLE	T0220	15070	1
28 *	OIL SEAL	25258-622	-----	1	69	NAME PLATE	38818-023	13990	1
29 *	SHAFT SLEEVE	11907	17030	1	70	SEAL DRAIN PLUG	P02	11990	1
30 *	IMPELLER SHIM SET	5091	17090	1	71 *	OIL SEAL	S1935	-----	1
31 *	SEAL PLATE	38272-517	10010	1	72	IMPELLER SHAFT	38514-807	16040	1
32 *	WEAR PLATE	2545	15990	1	73	INTERM GRD	42381-032	24150	1
33	HEX NUT	D08	15991	2	NOT SHOWN:				
34	LOCKWASHER	J08	15991	2		WARNING DECAL	38816-096	-----	1
35 *	BACK COVER ASSY	42111-935	-----	1		INTERM GRD	42381-031	24150	1
36	-COVER PLATE	NOT AVAILABLE		1		CLIP AIR ELIMINATOR	6006	-----	1
37	-WARNING PLATE	2613-EV	13990	1		STRAINER	7823-A	24000	1
38	-DRIVE SCREW	BM#04-03	15990	4		SUCTION STICKER	6588-AG	00000	1
39	-DRAIN PLUG	P04	11990	1		DISCHARGE STICKER	6588-BJ	00000	1
40 *	BACK COVER GSKT	7668-G	20000	1	OPTIONAL:				
41	CASING DRAIN PLUG	P16	11990	1		HARDENED IMPELLER	12584	11080	1

\* INDICATES PARTS RECOMMENDED FOR STOCK

SECTION DRAWING

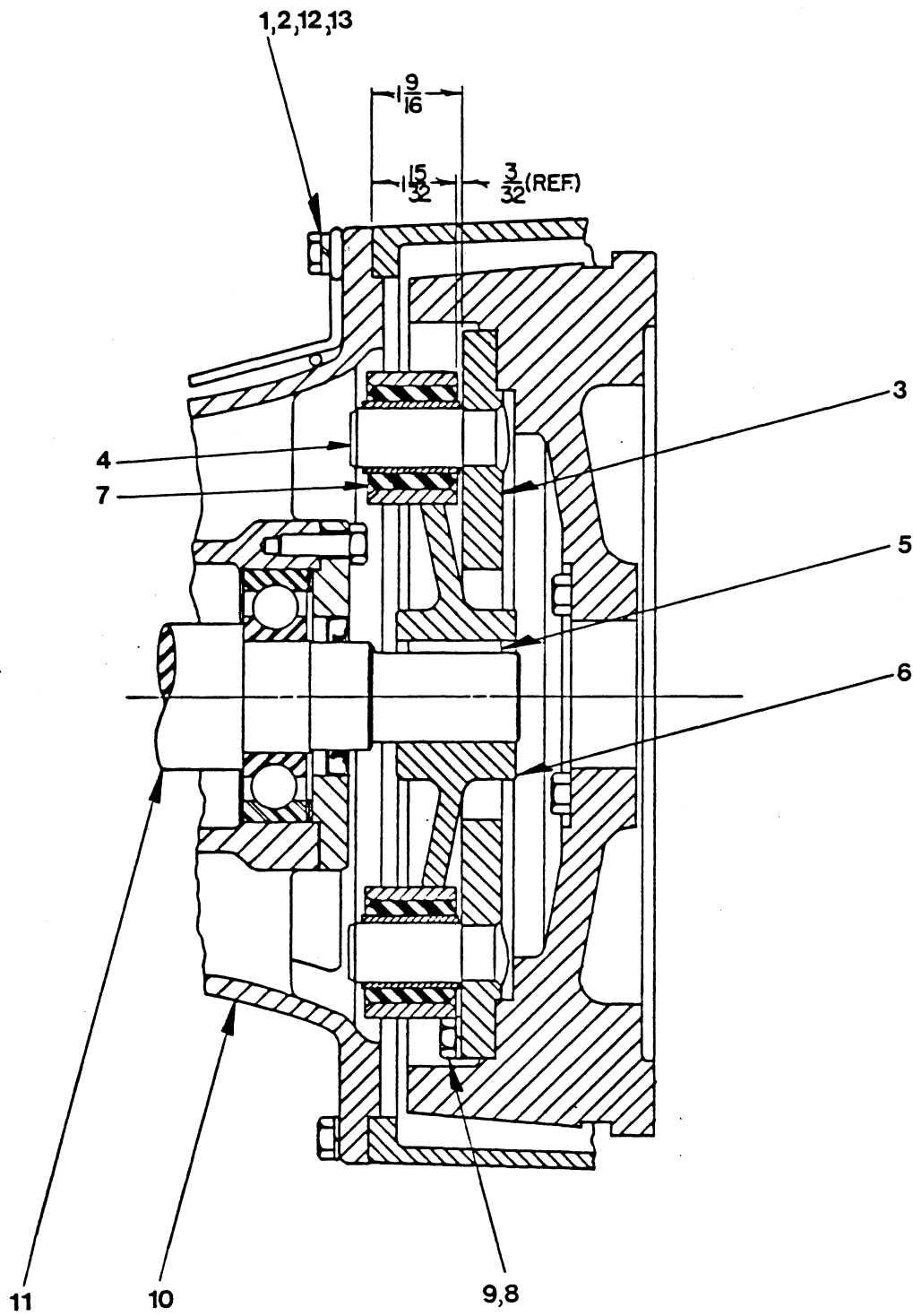

Figure 3. Drive Assembly For 16C20-F4L

**PARTS LIST**  
**Drive Assembly For 16C20-F4L**

ITEM NO.	PART NAME	PART NUMBER	MAT'L CODE	QTY
1	HEX HD CAPSCREW	22645-164	-----	12
2	LOCKWASHER	21171-511	-----	12
3	DRIVE PLATE ASSEMBLY	44131-005	24150	1
4	-DRIVE PIN	13819	15030	2
5	* SHAFT KEY	N0607	15990	1
6	DRIVE ARM ASSEMBLY	13817-D	-----	1
7	* -DYNA FLEX JOINT	S2110	-----	2
8	HEX HD CAPSCREW	22645-164	-----	8
9	LOCKWASHER	21171-511	-----	8
10	INTERMEDIATE	38263-614	10010	1
11	IMPELLER SHAFT	38514-807	16040	1
12	INTERMEDIATE GUARD	42381-031	24150	1
13	INTERMEDIATE GUARD	42381-032	24150	1

\* INDICATES PARTS RECOMMENDED FOR STOCK

## PUMP AND SEAL DISASSEMBLY AND REASSEMBLY



Review all warnings in Section A.

Follow the instructions on all tags, label and decals attached to the pump.

This pump requires little service due to its rugged, minimum-maintenance design. However, if it becomes necessary to inspect or replace the wearing parts, follow these instructions which are keyed to the sectional views (see Figures 1 2, and 3) and the accompanying parts lists.

Most service functions, such as wear plate, impeller, and seal replacement, may be performed by draining the pump and removing the back cover assembly. However, the following instructions assume complete disassembly is required.

Before attempting to service the pump, switch off the engine ignition and remove the key to ensure that it will remain inoperative. Close all valves in the suction and discharge lines.

For engine disassembly and repair, consult the literature supplied with the engine, or contact your local Deutz engine representative.



### BEFORE ATTEMPTING TO OPEN OR SERVICE THE PUMP:

1. FAMILIARIZE YOURSELF WITH THIS MANUAL.
2. SWITCH OFF THE ENGINE IGNITION AND REMOVE THE KEY TO ENSURE THAT THE PUMP WILL REMAIN INOPERATIVE.
3. ALLOW THE PUMP TO COOL IF OVERHEATED.
4. CHECK THE TEMPERATURE BEFORE OPENING ANY COVERS, PLATES, OR PLUGS.
5. CLOSE THE SUCTION AND DISCHARGE VALVES.
6. VENT THE PUMP SLOWLY AND CAUTIOUSLY.
7. DRAIN THE PUMP.

**USE LIFTING AND MOVING EQUIPMENT IN GOOD REPAIR AND WITH ADEQUATE CAPACITY TO PREVENT INJURIES TO PERSONNEL OR DAMAGE TO EQUIPMENT. THE BAIL IS INTENDED FOR USE IN LIFTING THE PUMP ASSEMBLY ONLY. SUCTION AND DISCHARGE HOSES AND PIPING MUST BE REMOVED FROM THE PUMP BEFORE LIFTING.**

### Back Cover Removal

(Figure 2)

Before attempting to service the pump, remove the pump casing drain plug (41) and drain the pump. Clean and reinstall the drain plug. The wear plate (32) and check valve (53) are easily accessible and may be serviced by removing the back cover assembly (35).

Remove the cover clamp screw (42) and clamp bar (43) securing the back cover. Pull the back cover and assembled wear plate from the pump casing (1). Inspect the back cover gasket (40) and replace it if damaged or worn.

Inspect the wear plate and replace it if badly scored and worn. To remove the wear plate, disengage the hardware (33 and 34).

### Suction Check Valve Removal

(Figure 2)

If the check valve assembly (53) is to be serviced, reach through the back cover opening and hold the assembly in place while removing the check valve pin (52). Slide the assembly from the check valve seat (49) and remove it from the pump.

### NOTE

*Further disassembly of the check valve is not required since it must be replaced as a complete unit. Individual parts are not sold separately.*

The check valve assembly may also be serviced by removing the suction flange (51). To remove

the flange, disengage the hardware (46 and 47) and separate the flange from the check valve seat (49). Remove the machine screws (50) and pull the seat and assembled check valve from the suction port. Remove the check valve pin (52) and pull the check valve assembly out of the seat.

Replace the flange gaskets (45 and 65) as required.

### Pump Casing Removal

(Figure 1)

To service the impeller or seal assembly, disconnect the suction and discharge piping. Remove the hardware (47, 48, and 49) securing the casing to the base (46).

(Figure 2)

Remove the nuts (11) securing the pump casing to the seal plate (31). Install a standard 5/8-11 UNC lifting eye in the tapped hole in the top of the pump casing. **Be sure** to screw the eye into the casing until fully engaged. Use a hoist and sling of suitable capacity to separate the casing from the seal plate and intermediate.



**DO NOT ATTEMPT TO LIFT THE COMPLETE PUMP UNIT USING THE LIFTING EYE. IT IS DESIGNED TO FACILITATE REMOVAL OR INSTALLATION OF INDIVIDUAL COMPONENTS ONLY. ADDITIONAL WEIGHT MAY RESULT IN DAMAGE TO THE PUMP OR FAILURE OF THE EYE BOLT.**

Remove any leveling shims used under the casing mounting feet. Tie and tag the shims for ease of reassembly.

### Impeller Removal

(Figure 2)

Before removing the impeller, drain the seal lubricant by removing the seal drain plug (70). Clean and reinstall the drain plug.

To remove the impeller (2), tap the vanes in counterclockwise direction (when facing the impeller) with a block of wood or soft-faced mallet. **Be careful** not to damage the impeller. When the impeller breaks loose, unscrew it from the shaft. Use caution when removing the impeller; tension on the shaft seal spring will be released as the impeller is unscrewed. Inspect the impeller and replace if cracked or badly worn.

Slide the impeller adjusting shims (30) off the impeller shaft (68). Tie and tag the shims or measure and record their thickness for ease of reassembly.

### Seal Removal and Disassembly

(Figure 2)

To remove the seal assembly (3), carefully remove the spring holder and spring. Slide the shaft sleeve and retainer assembly out of the seal plate bore and then slide the retainer assembly off the sleeve. Remove the rotating and stationary elements and assembled stationary seat with O-rings. Use a stiff wire with a hooked end if necessary.

### NOTE

*The seal assembly may be removed without completely disassembling the pump by removing the impeller through the back cover opening and using a stiff wire with a hooked end to pull the seal parts out of the seal plate.*

If no further disassembly is required, refer to Seal Reassembly And Installation.

### Separating Intermediate And Drive Assembly From engine

(Figure 3)

If it is necessary to separate the intermediate and drive assemblies from the engine, support the intermediate using a hoist and sling, and remove the hardware (1, 2, 12, and 13) securing the intermediate (10) to the engine bellhousing. Separate the assemblies by pulling the intermediate straight away from the engine.

As the assemblies are separated, the drive pins (4) will disengage from the drive arm assembly

(6). The drive arm assembly and the impeller shaft key (5) are a tight press fit on the shaft (11), and will remain on the shaft.

It is not necessary to remove the drive plate assembly (3) from the engine flywheel unless the drive pins are bent or worn and must be replaced. To remove the drive plate assembly, disengage the hardware (8 and 9) and remove the drive plate.

The drive pins are secured into the drive plate by a tight press fit and peening. To remove the pins, drill through from the peened end and drive the pins out using a drift pin.

Use a bearing puller to remove the drive arm assembly from the impeller shaft. Remove the shaft key.

Inspect the dyna flex joints (7), and replace them if worn. The dyna flex joints are a press fit in the drive arm.

### Shaft and Bearing Removal and Disassembly

(Figure 2)

When the pump is properly operated and maintained, the bearing housing should not require disassembly. Disassemble the shaft and bearings **only** when there is evidence of wear or damage.

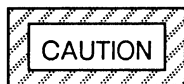

SHAFT AND BEARING DISASSEMBLY IN THE FIELD IS NOT RECOMMENDED. THESE OPERATIONS SHOULD BE PERFORMED ONLY IN A PROPERLY-EQUIPPED SHOP BY QUALIFIED PERSONNEL.

Remove the intermediate drain plug (27) and drain the lubricant. Clean and reinstall the drain plug.

Disengage the capscrews (19) and remove the bearing cap (24), gasket (18), outboard oil seal (23), and wavy washer (25). Press the oil seal from the bearing cap.

Place a block of wood against the impeller end of the shaft (72), and tap the shaft and assembled bearings from the intermediate. Press the inboard oil seal (28) from the intermediate.

After removing the shaft and bearings, clean and inspect the bearings in place as follows.



TO PREVENT DAMAGE DURING REMOVAL FROM THE SHAFT, IT IS RECOMMENDED THAT BEARINGS BE CLEANED AND INSPECTED IN PLACE. IT IS **STRONGLY** RECOMMENDED THAT THE BEARINGS BE REPLACED ANY TIME THE SHAFT AND BEARINGS ARE REMOVED.

Clean the intermediate, shaft and all component parts (except the bearings) with a soft cloth soaked in cleaning solvent. Inspect the parts for wear or damage and replace as necessary.



**MOST CLEANING SOLVENTS ARE TOXIC AND FLAMMABLE. USE THEM ONLY IN A WELL-VENTILATED AREA FREE FROM EXCESSIVE HEAT, SPARKS, AND FLAME. READ AND FOLLOW ALL PRECAUTIONS PRINTED ON SOLVENT CONTAINERS.**

Clean the bearings thoroughly in **fresh** cleaning solvent. Dry the bearings with filtered compressed air and coat with light oil.

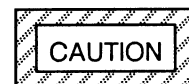

BEARINGS MUST BE KEPT FREE OF ALL DIRT AND FOREIGN MATERIAL. FAILURE TO DO SO WILL GREATLY SHORTEN BEARING LIFE. **DO NOT SPIN DRY BEARINGS.** THIS MAY SCRATCH THE BALLS OR RACES AND CAUSE PREMATURE BEARING FAILURE.

Rotate the bearings by hand to check for roughness or binding and inspect the bearing balls. If rotation is rough or the bearing balls are discolored, replace the bearings.

The bearing tolerances provide a tight press fit onto the shaft and a snug slip fit into the bearing



housing. Replace the bearings, shaft, or intermediate if the proper bearing fit is not achieved.

If bearing replacement is required, use a bearing puller to remove the inboard and outboard bearings (16 and 17) from the shaft.

**Shaft and Bearing Reassembly and Installation**

(Figure 2)

Inspect the shaft for distortion, nicks or scratches, or for thread damage on the impeller end. Dress small nicks and burrs with a fine file or emery cloth. Replace the shaft if defective.

Position the inboard oil seal (28) in the intermediate housing bore with the lip positioned as shown in Figure 2. Press the oil seal into the housing until the face is **just flush** with the machined surface on the housing.

Clean and inspect the bearings as indicated in **Shaft And Bearing Removal And Disassembly**.

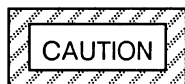

TO PREVENT DAMAGE DURING REMOVAL FROM THE SHAFT, IT IS RECOMMENDED THAT BEARINGS BE CLEANED AND INSPECTED IN PLACE. IT IS **STRONGLY** RECOMMENDED THAT THE BEARINGS BE REPLACED ANY TIME THE SHAFT AND BEARINGS ARE REMOVED.

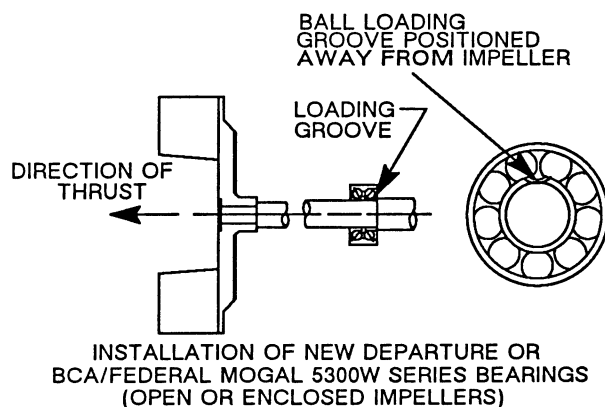

After the bearings have been installed and allowed to cool, check to ensure that they have not moved away from the shaft shoulders in

The bearings may be heated to ease installation. An induction heater, hot oil bath, electric oven, or hot plate may be used to heat the bearings. Bearings should **never** be heated with a direct flame or directly on a hot plate.

**NOTE**

*If a hot oil bath is used to heat the bearings, both the oil and the container must be **absolutely** clean. If the oil has been previously used, it must be **thoroughly** filtered.*

Heat the bearings to a uniform temperature **no higher than 250°F (120°C)**, and slide the bearings onto the shaft, one at a time, until they are fully seated. This should be done quickly, in one continuous motion, to prevent the bearings from cooling and sticking on the shaft.

**NOTE**

*Position the inboard bearing (16) on the shaft as indicated by the following illustrations.*

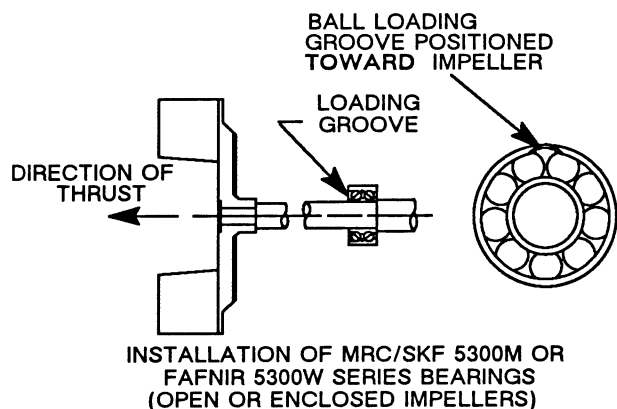

shrinking. If movement has occurred, use a suitable sized sleeve and a press to reposition the bearings against the shaft shoulders.

If heating the bearings is not practical, use a suitable sized sleeve, and an arbor (or hydraulic) press to install the bearings on the shaft.



WHEN INSTALLING THE BEARINGS ONTO THE SHAFT, **NEVER PRESS OR HIT AGAINST THE OUTER RACE, BALLS, OR BALL CAGE. PRESS ONLY ON THE INNER RACE.**

Slide the shaft and assembled bearings into the intermediate bore until the inboard bearing (16) is fully seated against the bore shoulder. **Be careful** not to damage the oil seal lip on the shaft threads.



WHEN INSTALLING THE SHAFT AND BEARINGS INTO THE BEARING BORE, PUSH AGAINST THE OUTER RACE. **NEVER HIT THE BALLS OR BALL CAGE.**

Apply a light coating of oil to the lip of the outboard oil seal (23), and press it into the bearing cap (24) with the lip positioned as shown in Figure 2. The face of the oil seal should be just flush with the outer face of the bearing cap.

Install the wavy washer (25) and bearing cap gasket (18), and secure the bearing cap to the intermediate with the capscrews (19). Be careful not to damage the oil seal lip on the shaft keyway.

Lubricate the bearings as indicated in LUBRICATION at the end of this section.

### Securing Intermediate And Drive Assembly To Engine

(Figure 3)

If the drive pins (4) were removed from the drive plate assembly (3), install the new pins by pressing them into the drive plate and peening the ends. Secure the drive plate assembly to the engine flywheel with the hardware (8 and 9).

If the dyna flex joints (7) were removed from the drive arm assembly, lubricate the O.D. of the replacement dyna flex joints with a fine film of rubber lubricant (Parker O Lube or equivalent), and press them into the drive arm until centered.

Install the impeller shaft key (5) and press the drive arm assembly (6) onto the impeller shaft.



MAKE CERTAIN THAT THE DRIVE PLATE AND DRIVE ARM ASSEMBLIES ARE MOUNTED IN ACCORDANCE WITH THE DIMENSIONS SHOWN IN FIGURE 3. THESE DIMENSIONS ARE CRITICAL. IF THE DRIVE ARM ASSEMBLY IS NOT PROPERLY POSITIONED ON THE SHAFT, A PRELOAD CONDITION CAN CAUSE PREMATURE BEARING FAILURE.

THE END OF THE SHAFT MUST BE RECESSED IN THE BORE OF THE DRIVE ARM 0.03 INCH. THIS WILL ALLOW A CLEARANCE OF APPROXIMATELY 3/32 INCH BETWEEN THE DRIVE ARM ASSEMBLY AND THE DRIVE PLATE AFTER THE INTERMEDIATE IS INSTALLED ON THE ENGINE BELLHOUSING.

### Seal Reassembly and Installation

(Figures 2 and 4)

Clean the seal cavity and shaft with a cloth soaked in fresh cleaning solvent.



**MOST CLEANING SOLVENTS ARE TOXIC AND FLAMMABLE. USE THEM ONLY IN A WELL-VENTILATED AREA FREE FROM EXCESSIVE HEAT, SPARKS, AND FLAME. READ AND FOLLOW ALL PRECAUTIONS PRINTED ON SOLVENT CONTAINERS.**

The seal is not normally reused because wear patterns on the finished faces cannot be realigned during reassembly. This could result in premature failure. If necessary to reuse an old seal in an emergency, **carefully** wash all metallic parts in fresh cleaning solvent and allow to dry thoroughly.

Handle the seal parts with extreme care to prevent damage. Be careful not to contaminate precision finished faces; even fingerprints on the faces can shorten seal life. If necessary, clean the faces with a non-oil based solvent and a clean, lint-free tissue. Wipe lightly in a concentric pattern to avoid scratching the faces.

Inspect the seal components for wear, scoring, grooves, and other damage that might cause leakage. Clean and polish the shaft sleeve, or replace it if there are nicks or cuts on either end.

If any components are worn, replace the complete seal; **never mix old and new seal parts.**

If a replacement seal is being used, remove it from the container and inspect the precision finished faces to ensure that they are free of any foreign matter.

To ease installation of the seal, lubricate the O-rings and disc with water or a very small amount of oil, and apply a drop of light lubricating oil on the finished faces. Assemble the seal as follows, (see Figure 4).

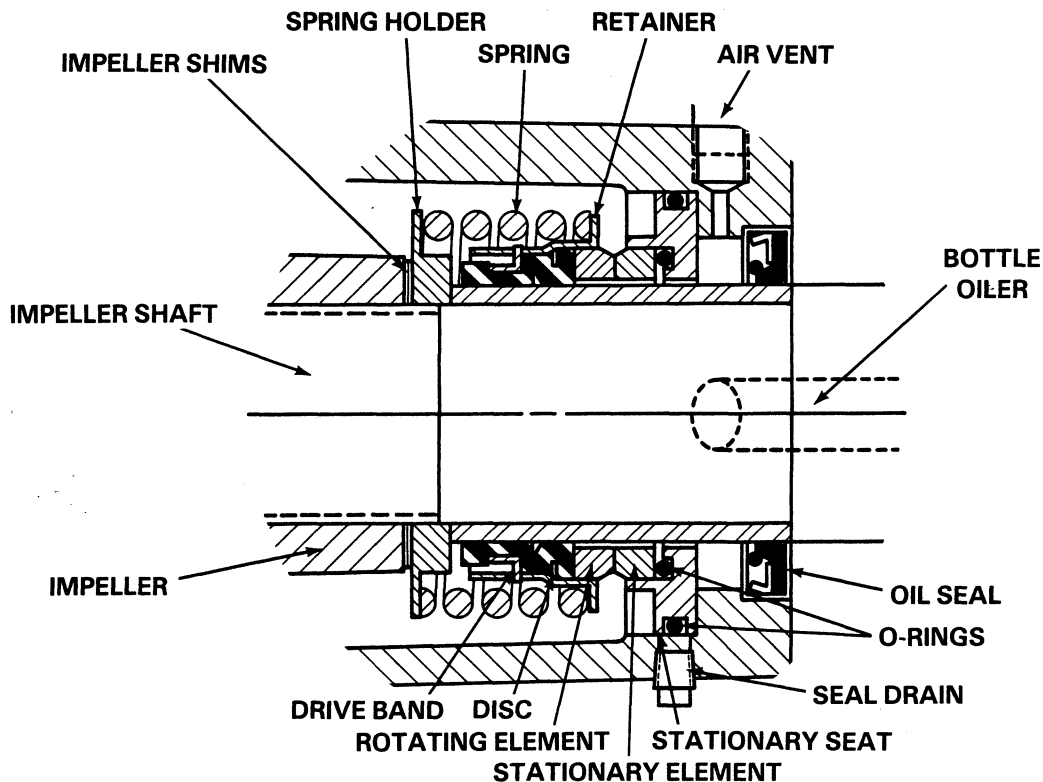

Figure 4. 12461 Seal Assembly



THIS SEAL IS NOT DESIGNED FOR OPERATION AT TEMPERATURES ABOVE 160° F. DO NOT USE AT HIGHER OPERATING TEMPERATURES.

Assemble the O-rings into the stationary element. Press the stationary element into the stationary seat with the chamfered side facing away from the seat. Press this assembly into the seal plate bore. A push tube cut from a length of plastic pipe would aid this installation. The I.D. of

the tube should be approximately the same as the I.D. of the seal spring.

Subassemble the rotating element in the retainer assembly with the chamfered side facing away from the retainer. Slide the assembly onto the shaft sleeve with the rotating element facing the chamfered end of the sleeve. Slide the sleeve onto the shaft until the seal elements contact and the sleeve bottoms against the shaft shoulder. **Be careful not to damage the seal plate oil seal (28).**

Install the spring and spring holder.

Reinstall the bottle oiler and piping (66, 67, and 68) and air vent and piping (12, 13, and 14).

Lubricate the seal as indicated in **LUBRICATION**, after the impeller has been installed.

### Impeller Installation And Adjustment

(Figure 2)

Inspect the impeller, and replace it if cracked or badly worn.



THE SHAFT AND IMPELLER THREADS **MUST BE COMPLETELY CLEAN BEFORE REINSTALLING THE IMPELLER. EVEN THE SLIGHTEST AMOUNT OF DIRT ON THE THREADS CAN CAUSE THE IMPELLER TO SEIZE TO THE SHAFT, MAKING FUTURE REMOVAL DIFFICULT OR IMPOSSIBLE WITHOUT DAMAGE TO THE IMPELLER OR SHAFT.**

Install the same thickness of impeller adjusting shims as previously removed, and screw the impeller onto the shaft until tight.

#### NOTE

*At the slightest sign of binding, immediately back the impeller off, and check the threads for dirt. Do not try to force the impeller onto the shaft.*

A clearance of .025 to .040 inch between the impeller and the seal plate is necessary for maximum pump efficiency. Measure this clearance, and add or remove impeller adjusting shims as required.

Remove the two capscrews temporarily holding the seal plate and install the same thickness of casing gaskets (9) as previously removed. Secure the seal plate and pump casing to the intermediate with the nuts (11). **Do not** fully tighten the nuts (11) until the impeller face clearance has been set.

A clearance of .010 to .020 inch between the impeller and the wear plate is also recom-

mended for maximum pump efficiency. This clearance must be set after installing the back cover, by adding or removing gaskets in the pump casing gasket set (9) until the impeller binds against the wear plate when the shaft is turned. After the impeller binds, add .015 inch of gaskets.

#### NOTE

*An alternate method of adjusting this clearance is to reach through the discharge port with a feeler gauge and measure the gap. Add or subtract pump casing gaskets accordingly.*

If a lifting eye was used to move the pump casing, **be sure** to remove the lifting eye from the pump casing.



**DO NOT ATTEMPT TO LIFT THE COMPLETE PUMP UNIT USING THE LIFTING EYE. IT IS DESIGNED TO FACILITATE REMOVAL OR INSTALLATION OF INDIVIDUAL COMPONENTS ONLY. ADDITIONAL WEIGHT MAY RESULT IN DAMAGE TO THE PUMP OR FAILURE OF THE EYE BOLT.**

### Suction Check Valve Installation

(Figure 2)

Inspect the check valve assembly, and replace it if badly worn.

#### NOTE

*The check valve assembly must be replaced as a complete unit. Individual parts are not sold separately.*

Reach through the back cover opening with the assembled check valve, and position the check valve adaptor in the mounting slot in the check valve seat. Align the adaptor with the seat hole and secure the assembly with the check valve pin (52).

#### NOTE

*If the suction flange or check valve seat was removed, replace the respective gaskets, apply*

*'Permatex Aviation No. 3 Form-A-Gasket' or equivalent compound to the mating surfaces.*

---

### Back Cover Installation

(Figure 2)

If the wear plate (51) was removed for replacement, carefully center it on the back cover and secure it with the hardware (33 and 34). The wear plate **must** be concentric to prevent binding when the back cover is installed.

Clean any scale or debris from the contacting surfaces in the pump casing that might interfere or prevent a good seal with the back cover. Replace the back cover gasket (40) and slide the back cover assembly into the pump casing. Be sure the wear plate does not bind against the impeller.

#### NOTE

*To ease future disassembly, apply a film of grease or 'Never-Seez' on the back cover shoulder, or any surface which contacts the pump casing. This action will reduce rust and scale build-up.*

---

Secure the back cover assembly by tightening the cover clamp screw (42). **Do not** over-tighten the clamp screw; it should be just tight enough to ensure a good seal at the back cover shoulder.

### Final Pump Assembly

(Figure 1)

Install any leveling shims used under the pump casing mounting feet and secure the casing to the base (46) with the hardware (47, 48, and 49). **Be sure** the pump is secured to the base and engine.

Install the suction and discharge lines and open all valves. Make certain that all piping connections are tight, properly supported and secure.

**Be sure** the pump end and engine have been properly lubricated, see **LUBRICATION**.

Fill the pump casing with clean liquid. Reinstall the fill cover plate and tighten it.

Refer to **OPERATION**, Section C, and start the pump.

## LUBRICATION

### Seal Assembly

(Figure 2)

Fill the bottle oiler (66) with SAE non-detergent motor oil, making certain to vent the seal cavity at the air vent (12) while filling. Check the oil level regularly and keep the bottle oiler full.

### Bearings

(Figure 2)

The intermediate was fully lubricated when shipped from the factory. Check the oil level regularly through the sight gauge (20) and maintain it at the middle of the gauge. When lubrication is required, add SAE No. 30 non-detergent oil through the oil hole cover (15). **Do not** over-lubricate. Over-lubrication can cause the bearings to over-heat, resulting in premature bearing failure.

#### NOTE

*The white reflector in the sight gauge must be positioned horizontally to provide proper drainage.*

---

Under normal conditions, drain the intermediate once each year and refill with clean oil. Change the oil more frequently if the pump is operated continuously or installed in an environment with rapid temperature change.

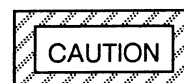

**MONITOR THE CONDITION OF THE BEARING LUBRICANT REGULARLY FOR EVIDENCE OF RUST**

OR MOISTURE CONDENSATION. THIS IS ESPECIALLY IMPORTANT IN AREAS WHERE VARIABLE HOT AND COLD TEMPERATURES ARE COMMON.

For cold weather operation, consult the factory or a lubricant supplier for the recommended grade of oil.

**Engine**

Consult the literature supplied with the power source, or contact your local Deutz engine representative.



**For U.S. and International Warranty Information,  
Please Visit [www.grpumps.com/warranty](http://www.grpumps.com/warranty)  
or call:  
U.S.: 419-755-1280  
International: +1-419-755-1352**

**For Canadian Warranty Information,  
Please Visit [www.grcanada.com/warranty](http://www.grcanada.com/warranty)  
or call:  
519-631-2870**