

# INSTALLATION, OPERATION, AND MAINTENANCE MANUAL

WITH PARTS LIST



## SUBMERSIBLE PUMPS

Record Pump Serial Number \_\_\_\_\_

MODEL
S2A1 230V 1P

**THE GORMAN-RUPP COMPANY • MANSFIELD, OHIO**

GORMAN-RUPP OF CANADA LIMITED • ST. THOMAS, ONTARIO, CANADA Printed In U.S.A.

©Copyright by the Gorman-Rupp Company

## TABLE OF CONTENTS

<b>INTRODUCTION</b> . . . . .	<b>I-1</b>
<b>WARNINGS - SECTION A</b> . . . . .	<b>A-1</b>
<b>INSTALLATION - SECTION B</b> . . . . .	<b>B-1</b>
<b>PREINSTALLATION INSPECTION</b> . . . . .	<b>B-1</b>
Lubrication . . . . .	<b>B-2</b>
<b>PUMP INSTALLATION</b> . . . . .	<b>B-2</b>
Pump Specifications . . . . .	<b>B-2</b>
Pump Dimensions . . . . .	<b>B-2</b>
Lifting . . . . .	<b>B-3</b>
Positioning The Pump . . . . .	<b>B-4</b>
Piping . . . . .	<b>B-5</b>
<b>CONTROL BOX INSTALLATION</b> . . . . .	<b>B-5</b>
Enclosure . . . . .	<b>B-5</b>
Grounding Methods . . . . .	<b>B-9</b>
Field Wiring Connections (Incoming Power) . . . . .	<b>B-10</b>
Pump Power Cable Connections . . . . .	<b>B-11</b>
<b>LIQUID LEVEL DEVICES</b> . . . . .	<b>B-12</b>
<b>OPERATION - SECTION C</b> . . . . .	<b>C-1</b>
<b>CONTROL BOX FUNCTION</b> . . . . .	<b>C-1</b>
Component Function . . . . .	<b>C-1</b>
<b>PUMP OPERATION</b> . . . . .	<b>C-2</b>
Liquid Temperature And Overheating . . . . .	<b>C-2</b>
Checking Pump Rotation . . . . .	<b>C-3</b>
<b>STARTING</b> . . . . .	<b>C-4</b>
Standard Pump (No Liquid Level Devices) . . . . .	<b>C-5</b>
With Automatic Liquid Level Devices . . . . .	<b>C-5</b>
<b>STOPPING</b> . . . . .	<b>C-5</b>
Operation Checks . . . . .	<b>C-5</b>
Cold Weather Preservation . . . . .	<b>C-6</b>
<b>TROUBLESHOOTING - SECTION D</b> . . . . .	<b>D-1</b>
<b>TROUBLESHOOTING CHART</b> . . . . .	<b>D-1</b>
<b>ELECTRICAL TESTING</b> . . . . .	<b>D-4</b>
Test Equipment . . . . .	<b>D-4</b>
Motor And Motor Power Cable Continuity . . . . .	<b>D-4</b>
Insulation Resistance . . . . .	<b>D-5</b>
Capacitors . . . . .	<b>D-6</b>
Start Relay . . . . .	<b>D-6</b>
<b>MAINTENANCE AND REPAIR - SECTION E</b> . . . . .	<b>E-1</b>
<b>PERFORMANCE CURVE</b> . . . . .	<b>E-1</b>
<b>PUMP MODEL - PARTS LIST</b> . . . . .	<b>E-3</b>
<b>PUMP AND MOTOR DISASSEMBLY AND REASSEMBLY</b> . . . . .	<b>E-4</b>
<b>PUMP END DISASSEMBLY</b> . . . . .	<b>E-5</b>
Strainer And Wear Plate Disassembly . . . . .	<b>E-5</b>
Draining Oil From Seal And Motor . . . . .	<b>E-5</b>
Positioning Pump For Disassembly . . . . .	<b>E-5</b>
Impeller Disassembly . . . . .	<b>E-6</b>
Seal Disassembly . . . . .	<b>E-6</b>
<b>PUMP END REASSEMBLY</b> . . . . .	<b>E-7</b>
Cleaning Old Parts . . . . .	<b>E-7</b>
Seal Reassembly . . . . .	<b>E-9</b>
Impeller Reassembly . . . . .	<b>E-10</b>
Impeller Clearance . . . . .	<b>E-11</b>
Strainer Screen And Base Plate Reassembly . . . . .	<b>E-11</b>
<b>MOTOR DISASSEMBLY</b> . . . . .	<b>E-11</b>
Terminal Housing/Power Cable Disassembly . . . . .	<b>E-12</b>
Rotor Disassembly . . . . .	<b>E-13</b>

Stator Disassembly	E-13
Relief Valve	E-14
Hoisting Bail	E-14
MOTOR REASSEMBLY	E-14
Stator Reassembly	E-15
Rotor Reassembly	E-15
Terminal Housing And Power Cable Reassembly	E-17
Power Cable Potting	E-18
LUBRICATION	E-21
Seal Cavity	E-22
Motor Housing Cavity	E-22
FINAL ASSEMBLY	E-22

INTRODUCTION

This Installation, Operation, and Maintenance Manual is designed to help you achieve the best performance and longest life from your Gorman-Rupp pump.

This pump is designed to operate fully or partially submerged. It is capable of handling most nonvolatile and nonflammable liquids which are mildly corrosive and abrasive. The basic material of construction is aluminum with ductile iron diffuser and impeller, and steel wear plate. The integral electric motor must be operated through the control box furnished with the pump. Neither the pump motor nor control box are explosion proof and should not be operated in a hazardous atmosphere.

If there are any questions regarding the pump or motor which are not covered in this manual or in other literature accompanying this unit, please contact your Gorman-Rupp distributor or the Gorman-Rupp Company:

The Gorman-Rupp Company	or	Gorman-Rupp of Canada Limited
P.O. Box 1217		70 Burwell Road
Mansfield, Ohio 44901-1217		St. Thomas, Ontario N5P 3R7

The following are used to alert maintenance personnel to procedures which require special attention, to those which could damage equipment, and to those which could be dangerous to personnel:

NOTE

Instructions to aid in installation, operation, and maintenance or which clarify a procedure.

CAUTION

Instructions which must be followed to avoid causing damage to the product or other equipment incidental to the installation. These instructions describe the requirements and the possible damage which could result from failure to follow the procedures.

WARNING

```

////////////////////////////////////
//
// These instructions must be followed to avoid causing in- //
// jury or death to personnel, and describe the procedure //
// required and the injury which could result from failure //
// to follow the procedure. //
// //
////////////////////////////////////

```



WARNINGS

WARNINGS - SECTION A

THESE WARNINGS APPLY TO THE "S-SERIES" SUBMERSIBLE MOTOR OPERATED PUMPS.

WARNING

```

////////////////////////////////////
//
// Before attempting to open or service the pump:
//
// 1. Familiarize yourself with this manual.
// 2. Lock out the power supply to the control panel to
// ensure that the pump will remain inoperative.
// 3. Allow the pump to cool if overheated.
// 4. Close the discharge valve (if used).
//
////////////////////////////////////

```

WARNING

```

////////////////////////////////////
//
// Do not attempt to pump volatile or flammable liquids for
// which this pump has not been designed.
//
////////////////////////////////////

```

WARNING

```

////////////////////////////////////
//
// Before connecting any cable to the control box, be sure
// to ground the control box. See Figure 4 on page B-9 for
// suggested grounding methods.
//
////////////////////////////////////

```

WARNING

```

////////////////////////////////////
//
// After the pump has been installed, make certain that the
// pump and all piping or hose connections are secure be-
// fore operation.
//
////////////////////////////////////

```

WARNING

```

////////////////////////////////////
//
// The pump motor is designed to be operated through the
// control box furnished with the pump. The control box
// provides overload protection and power control. Do not
// connect the pump motor directly to the incoming power
// lines.
//
////////////////////////////////////

```

WARNINGS

WARNING

```

////////////////////////////////////
//
// All electrical connections must be in accordance with //
// the National Electric Code and all local codes. If //
// there is a conflict between the instructions provided //
// and N.E.C. specifications, N.E.C. specifications shall //
// take precedence. All electrical equipment supplied with //
// this pump was in conformance with N.E.C. requirements in //
// effect on the date of manufacture. Failure to follow //
// applicable specifications, or substitution of electrical //
// parts not supplied or approved by the manufacturer, can //
// result in severe injury or death. //
// //
////////////////////////////////////

```

WARNING

```

////////////////////////////////////
//
// The electrical power used to operate this pump is high //
// enough to cause injury or death. Make certain that the //
// control box is grounded, and that the power supply is //
// compatible with the motor phase and voltage, before con- //
// necting the power source. If the overload unit is //
// tripped during pump operation, correct the problem be- //
// fore restarting the pump. //
// //
////////////////////////////////////

```

WARNING

```

////////////////////////////////////
//
// Obtain the services of a qualified electrician to con- //
// nect the electrical circuits, and to service the control //
// box. //
// //
////////////////////////////////////

```

WARNING

```

////////////////////////////////////
//
// Do not attempt to lift the pump by the motor power cable //
// or the piping. Attach proper lifting equipment to the //
// hoisting bail fitted to the pump. //
// //
////////////////////////////////////

```

---

---

## INSTALLATION

---

---

### INSTALLATION - SECTION B

This section is intended only to summarize recommended installation practices for the pump and control box. If there are any questions concerning your specific installation, contact your Gorman-Rupp distributor or the Gorman-Rupp Company.

Automatic liquid level devices are not furnished with the standard pump, but are available from Gorman-Rupp as options (see **Liquid Level Devices**, Section B); for information on installing and operating these devices, see the technical data accompanying that option.

#### PREINSTALLATION INSPECTION

The pump assembly and control box were inspected and tested before shipment from the factory. Before installation, check for damage which may have occurred during shipment. Check as follows:

- a. Check the pump assembly for cracks, dents, damaged threads, and other obvious damage.
- b. Check for and tighten loose bolts, nuts, capscrews, and other attaching hardware. Since gaskets tend to shrink after drying, check for and tighten loose hardware securing all mating surfaces.
- c. The standard pump is connected to the control box with 50 ft. of power cable. Inspect the cable for cuts or damage.
- d. Check the control box for cracks, dents, and other obvious damage.
- e. Check that all control box components are securely attached to their mounting surfaces, and that the electrical connections are tight and free of corrosion.
- f. Compare the amperes, phase, voltage, and hertz indicated on the motor name plate to the ratings indicated for the control box.
- g. Carefully read all tags, decals, and markings on the pump assembly and the control box, and perform all duties indicated.
- h. Check the pump and motor for any oil leaks. An oil leak may indicate a cut O-ring or other damage.
- i. If the pump and control box have been stored for more than 12 months, some of the components or lubricants may have exceeded their maximum shelf life. These **must be inspected or replaced** to insure maximum pump service.

If the maximum shelf life has been exceeded, or if anything appears to be abnormal, contact your Gorman-Rupp distributor or the factory to determine the repair or updating policy. **Do not** put the pump into service until appropriate action has been taken.



---



---

**INSTALLATION**

---



---

**Lubrication**

There are two lubrication cavities in this pump, both contain premium quality submersible pump oil. The motor housing cavity provides lubrication to the motor assembly and rotor shaft bearings. The intermediate cavity provides lubrication to the seal assembly.

The seal assembly is double faced. It is designed to prevent the liquid being pumped from entering the intermediate cavity at the impeller end, and to prevent moisture from entering the motor housing cavity at the motor end.

Both cavities are fully lubricated when the pump is shipped from the factory. Check lubrication levels before installing the pump (see **LUBRICATION** in **MAINTENANCE AND REPAIR**). An additional quart of oil has been provided with the pump to "top off" the oil cavities.

**PUMP INSTALLATION****Pump Specifications**

See Table 1 for the typical pump specifications and motor data.

**Table 1. Pump Specifications**

Model Number	Voltage/Phase	Pump Horsepower	Motor Speed (RPM)	Full Load Amperes	No Load Amperes	Locked Rotor Amperes	Discharge Size (NPT)
S2A1	230/1	2	3450	14	7	44	2

**Pump Dimensions**

The standard pump is provided with a suction strainer to prevent large solids from clogging the impeller. On high discharge head applications, the strainer can be replaced with an optional staging adaptor to allow one pump to feed another.

See Figure 1 on page B-3 for the approximate physical dimensions of the pump.

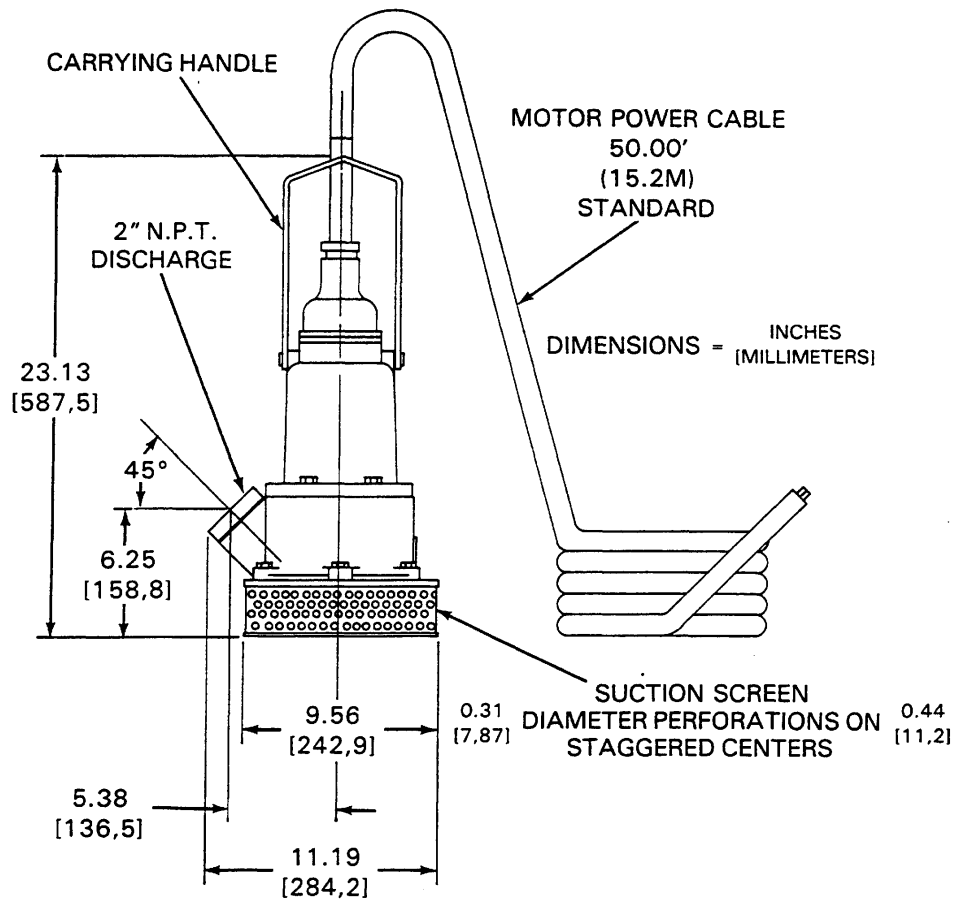

Figure 1. Pump Model S2A1-230V 1P

**Lifting**

Use lifting equipment with a capacity of a least **340 pounds**. This pump weighs approximately **68 pounds**, not including the weight of accessories and control box. Customer installed equipment such as rigid piping **must** be removed before attempting to lift.

INSTALLATION

WARNING

```

////////////////////////////////////
//
// Do not attempt to lift the pump by the motor power cable //
// or the piping. Attach proper lifting equipment to the //
// hoisting bail fitted to the pump. If chains or cable //
// are wrapped around the pump to lift it, make certain //
// that they are positioned so as not to damage pump, and //
// so that the load will be balanced. //
// //
////////////////////////////////////

```

Positioning The Pump

This pump is designed to operate fully or partially submerged. It may also be operated in air for extended periods. The rotating parts are oil lubricated, and the motor is cooled by a constant flow of liquid or air discharged through internal passage(s).

As a safe guard against rupture or explosion due to heat, the pump is fitted with a pressure relief valve which will open if vapor pressure within the pump motor reaches a critical point.

The pump will operate if positioned on its side, but this is not recommended because the motor torque could cause the pump to roll during operation.

The pump should be independently secured and supported by the hoisting bail. If the application involves a lot of debris, protect the pump from excessive wear and clogging by suspending it in a perforated barrel or culvert pipe. If the bottom is heavily sludge-covered, rest the pump on support blocks or suspend it from a raft or similar device near the surface of the liquid. See Figure 2 on page B-5 for typical pump installations.

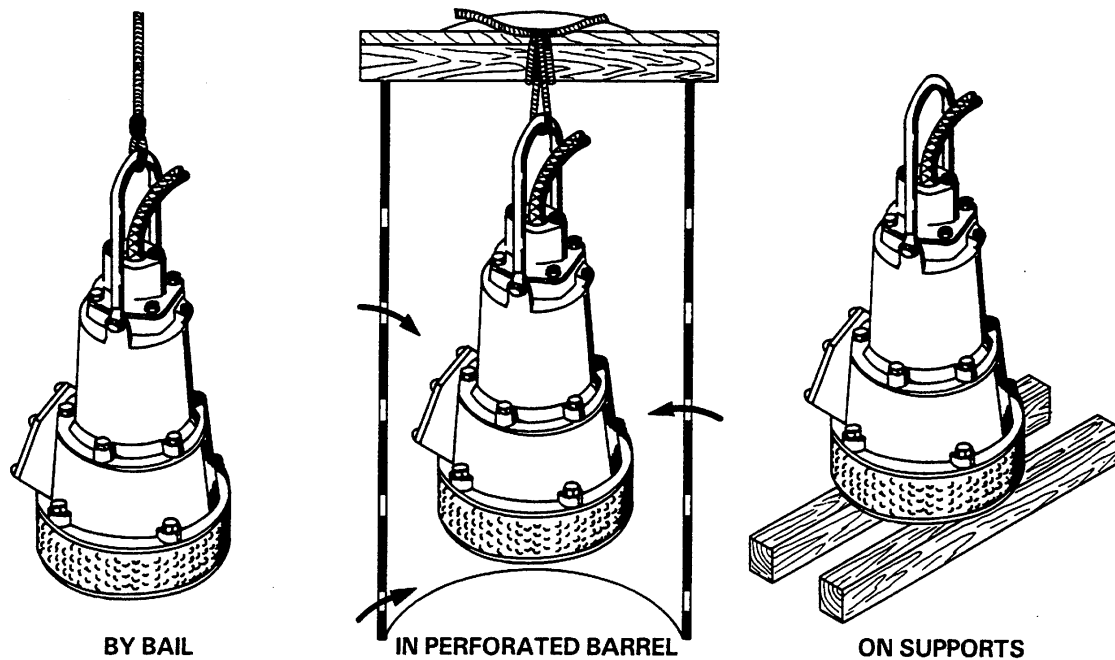

Figure 2. Typical Pump Installations.

All liquid entering the pump must pass through a strainer screen. Any spherical solids which pass through the screen will pass through the pump.

#### NOTE

Before actual operation, check the direction of impeller rotation to ensure that the pump is properly wired to the control box. See **Checking Pump Rotation** in **OPERATION** section.

#### Piping

No suction piping is required in a standard submerged application.

If an optional suction staging adaptor is installed, the discharge from one pump may be piped to the suction of another. To determine the size of the discharge connection, see Table 1, PUMP SPECIFICATIONS. Either hose or rigid pipe may be used. To facilitate mobility and maintenance, it is recommended that the discharge line be fitted with a quick disconnect fitting near the pump. The discharge line must be independently supported to avoid strain and vibration on the pump.

INSTALLATION

For maximum pumping capacity, keep the discharge as short and straight as possible. Minimize the use of elbows and fittings which increase friction losses through the discharge piping system.

It is recommended that a check valve or throttling valve be installed in the discharge line to control siphoning or back flow when the pump is shut off.

CONTROL BOX INSTALLATION

This pump is driven by an integral 230 VAC, 60 hertz, 1 phase, 2 HP motor. It is designed to operate through the control box furnished with the pump.

WARNING

```

////////////////////////////////////
//                               //
// The pump motor is designed to be operated through the //
// control box furnished with the pump. The control box //
// provides overload protection and power control. Do not //
// connect the pump motor directly to the incoming power //
// lines. //
//                               //
////////////////////////////////////

```

Enclosure

The control box is a rainproof enclosure with a padlockable front cover. **The enclosure is not designed to be watertight, and should not be submerged.** See Figure 3 on page B-7 for enclosure dimensions and callouts.

Secure the control box vertically on a level surface, which is above flood level. It should be easily accessible to the operator, and located close enough to the pump to avoid excessive voltage drop due to cable length. (See **Pump Power Cable Connections**). After the box is installed, make certain the front cover latches properly.

CAUTION

<p>Failure to mount the control box vertically on a level surface may affect operation of the pump controls.</p>
--

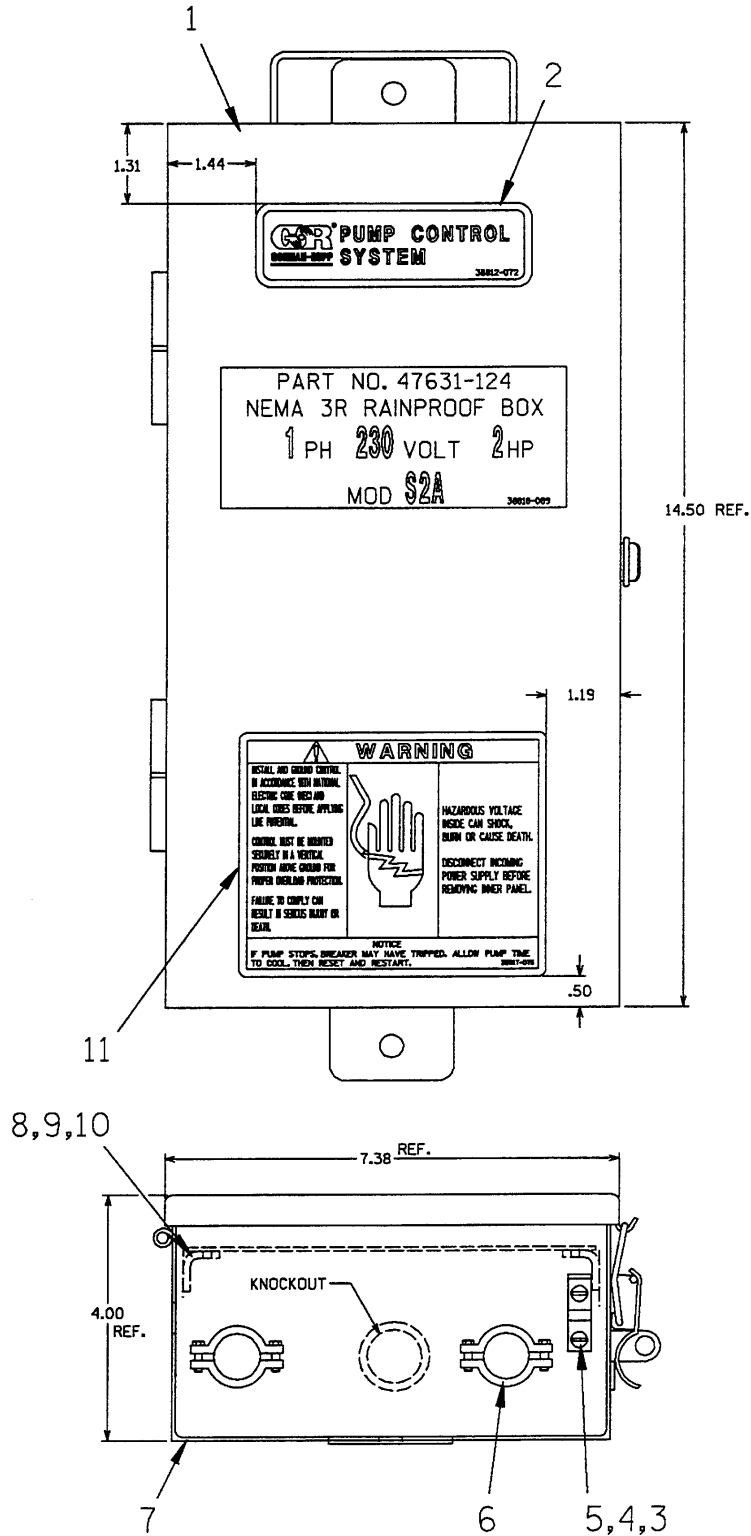

Figure 3. 47631-124 Control Box Assembly

**PARTS LIST, EXTERNAL PARTS**  
**47631-124 CONTROL BOX ASSEMBLY**  
 See Figure 8 on page B-15 for internal parts

ITEM NO.	PART NAME	PART NUMBER	MATL CODE	QTY
1	FRONT COVER	42821-267	-----	1
2	PUMP CONT. SYS. STICKER	38812-072	-----	1
3	GROUND LUG	27222-002	-----	2
4	PHILLIP HD MACHINE SCREW	21771-553	-----	1
5	HEX NUT	D#08	15991	1
6	CABLE CLAMP	27184-164	-----	2
7	CONTROL BOX SUB-ASSY	42821-241	-----	1
8	INNER PANEL	33643-096	15121	1
9	PHILLIPS HD MACH SCREW	21771-553	-----	4
10	WARNING STICKER	38817-075	-----	1
11	WARNING STICKER	38817-075	-----	1

## Grounding Methods

Electrically ground the installation before connecting the field wiring to the control box. Install a grounding terminal to the enclosure and connect it to a properly imbedded electrode.

The material used for the electrode **must** be an excellent conductor of electricity, such as copper. If iron or steel is used, it must be galvanized or otherwise metal plated to resist corrosion. **Do not** coat the electrode with any material of poor conductivity such as paint or plastic.

The electrode must conform to the recommendations of N. E. C. Article 250. Follow all installation requirements of the N.E.C., and all applicable local codes. See Figure 4 for some suggested grounding methods.

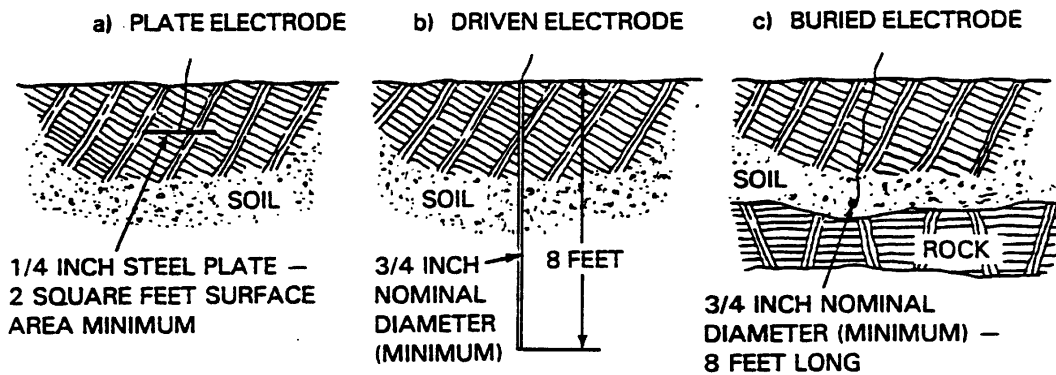

Figure 4. Suggested Grounding Methods

- a. **Plate Electrode:** An iron or steel plate, 1/4 inch thick, completely imbedded in the ground. The plate must present a surface of a least 2 square feet.
- b. **Driven Electrode:** A rod or pipe, 3/4 inch diameter minimum, 8 feet long, completely driven into the ground.
- c. **Buried Electrode:** If rock or stone prevents imbedding the full 8 foot length of the ground rod, bury it in a horizontal trench.

Space the ground rod or plates at least 6 feet from any other electrode or ground rod, such as those used for signal circuits, radio grounds, lightning rods, etc.

The earth surrounding the ground rod or plate **must** contain enough moisture to make a good electrical connection. In dry or sandy areas, pour water around the rod or consult qualified personnel to devise a method of improving the connection.



**WARNING**

```

////////////////////////////////////
//
// The electrical power used to operate this pump is high //
// enough to cause injury or death. Make certain that the //
// control box is properly grounded after installation. //
//
////////////////////////////////////

```

Field Wiring Connections (Incoming Power)

**WARNING**

```

////////////////////////////////////
//
// The electrical power used to operate this pump is high //
// enough to cause injury or death. Obtain the services of //
// a qualified electrician to make all electrical con- //
// nections. Make certain that the pump and enclosure are //
// properly grounded, and that the incoming power matches //
// the requirements of the pump and control. //
//
////////////////////////////////////

```

The pump control is designed to regulate a 230 volt, 1 phase, 60 hertz power supply. The field wiring must be properly sized to insure an adequate voltage supply. The voltage available **at the motor** must be within the range indicated in Table 2.

To calculate the voltage available at the motor proceed as follows:

- a. Measure the incoming voltage across lines (1 & 2) while the pump is **operating at full capacity**. See Figure 6 on page B-14 or Figure 8 on page B-15.
- b. Next, subtract the motor cable voltage drop (see Table 3, Motor Cable Specifications).
- c. Do not continue to operate the pump if this voltage is not within the recommended limits. Obtain the services of a qualified electrician to determine the correct field wiring size and other details to insure an adequate voltage supply to the pump.

**Table 2. Pump Motor Voltage Limits**

Nominal Voltage	Phase	Minimum Voltage	Maximum Voltage
230	1	220	245

Use conduit or cable clamps to secure the incoming field wiring to the control box. Make certain all connections are tight and that cable entry points are

rainproof. Support the cable weight, if required, to prevent excessive strain on cable clamps and cable.

Pump Power Cable Connections

**WARNING**

```

////////////////////////////////////
//
// The electrical power used to operate this pump is high //
// enough to cause injury or death. Make certain that in- //
// coming power is OFF and LOCKED OUT before connecting //
// power or accessory cables to the control box. Obtain //
// the services of a qualified electrician to make all //
// electrical connections. //
// //
////////////////////////////////////
    
```

The standard pump is provided with a 50-foot (15,2m) power cable sealed by heat-shrink tubing in the terminal housing assembly. (See Table 3 for cable specifications.) If a longer power cable is required, an optional cable assembly **must** be ordered from the factory. Splicing of the power cable is **not** recommended by the Gorman-Rupp Company due to safety and warranty considerations.

**WARNING**

```

////////////////////////////////////
//
// Never attempt to alter the length or repair any power //
// cable with a splice. The pump motor and cable must be //
// completely waterproof. Injury or death may result from //
// alterations. //
// //
////////////////////////////////////
    
```

**Table 3. Cable Requirements for Pump Electrical Connections, Model S2A1**

Voltage/ Phase	A.W.G. Cable Size	Cable OD (inches)	Conductor Dia. (inches)	Amp Rating* at 30°C (amperes)	DC Resist- ance at 25°C (ohms/ 1000 ft)	Voltage Drop at Max. Load per 100 ft
230/1	14	0.61	0.075	15	2.73	7.64

\*Applies only to S0 type cable. Refer to manufacturer's specifications for other cable.

Before connecting the pump power cable to the control box, make certain the incoming power is **OFF** and **LOCKED OUT**. Make certain the control box is **PROPERLY GROUNDED** and that the electrical data on the control matches the motor name plate data.

Connect the pump power cable to the control box as shown in Figure 6 on page B-14 or Figure 8 on page B-15. Use conduit or cable clamps to secure the power and

accessory cables to the control box. Make certain that all connections are tight and that cable entry points are rainproof.

### LIQUID LEVEL DEVICES

The standard pump is **not** furnished with a means to automatically regulate liquid level. However, the pump may be controlled to perform filling, or dewatering functions by using **either** of the following optional sensing devices: (see Figure 5 on page B-13).

- **Diaphragm Type:** two fixed position sensors (upper and lower) each contain a diaphragm which flexes with changes in liquid level, thus activating an enclosed miniature switch.
- **Bulb (Float) Type:** a bulb raises or lowers (floats) with the liquid level, thus activating an enclosed miniature switch.

Liquid level devices operate through a separate control box wired between the main control box and the pump. The liquid level control box may be purchased with the pump or easily added in the field by qualified personnel. The unit is complete except for remote float switches, which must be specified and purchased separately. For installation and operation of the liquid level control box, see the detailed instructions included with the control box.

### CAUTION

Liquid level devices **MUST** be positioned far enough apart to allow 10 minutes between starts. If the pump motor cycles more than 6 starts per hour, it will overheat resulting in damage to the motor windings or control box components.

TYPICAL INSTALLATION

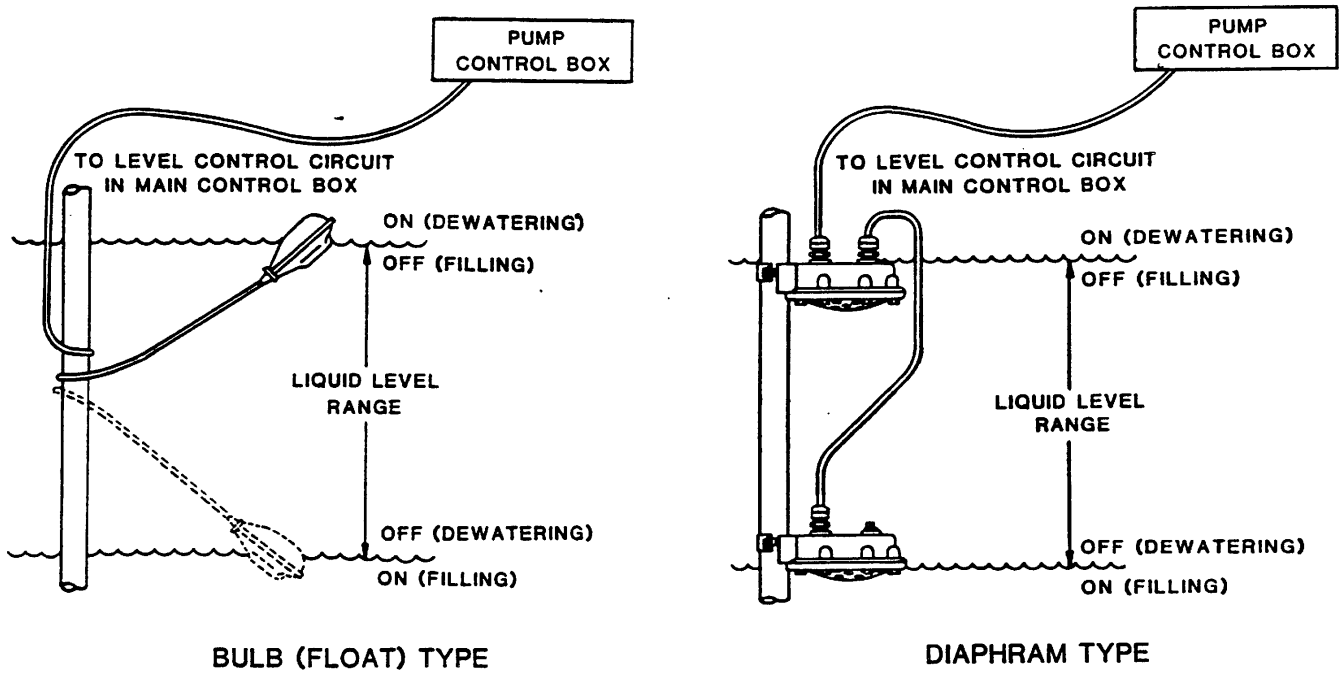

Figure 5. Liquid Level Devices

CAUTION

The internal wiring of the sensing devices are different for filling and dewatering functions. Be sure to follow the instructions included with the option before making wiring connections.

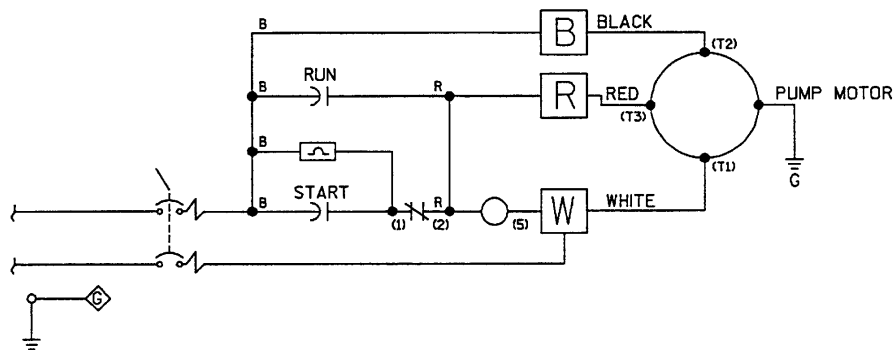
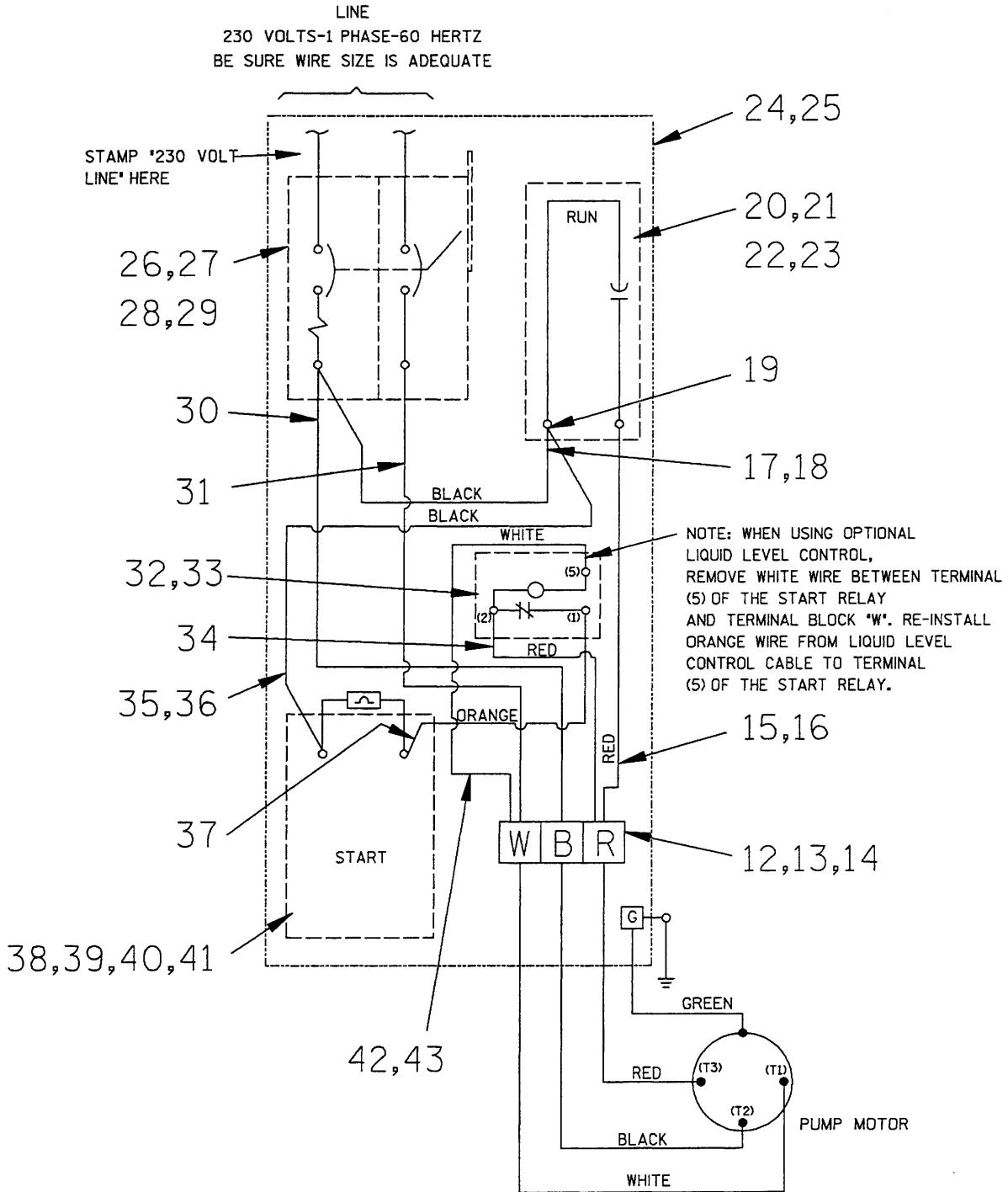

Figure 6. Elementary Wiring Diagram  
47631-124 Control Box

If liquid level controls are to be installed, connect the motor power cables and level control power cables as shown on page B-15.

See Figure 7 on page B-15 for a pictorial wiring diagram and callouts of the control box assembly internal parts.



NOTE  
WHEN ONLY ONE LIQUID LEVEL SWITCH IS USED,  
CONNECT TO TERMINALS L AND U.  
VOLTAGE TO FLOAT SWITCHES - 120 VOLTS TO GROUND.

Figure 7. 47631-124 Control Box Assembly -  
Pictorial Wiring Diagram

**PARTS LIST INTERNAL PARTS**  
**47631-124 CONTROL BOX ASSEMBLY**  
 See Figure 3 on Page B-7 for external parts

ITEM NO.	PART NAME	PART NUMBER	MATL CODE	QTY
12	END BARRIER	27233-026	-----	1
13	TERMINAL BLOCK	27233-216	-----	3
14	PHILLIPS HD MACH SCREW	21771-552	-----	2
15	FEMALE CONNECTOR	S1768	-----	1
16	FT #10 AWG TEW/AWM RED	18162-042	-----	1
17	FT #10 AWG TEW/AWM BLK	18162-043	-----	1
18	FEMALE CONNECTOR	S1768	-----	1
19	FEMALE CONNECTOR	S1790	-----	1
20	RUN CAPACITOR 7.5 MFD 440 VAC	27571-323	-----	1
21	PHILLIPS HD MACH SCREW	21771-552	-----	2
22	RUN CAPACITOR BRACKET	27581-907	-----	2
23	PHILLIPS HD MACH SCREW	21771-551	-----	1
24	SUB-PLATE	34621-153	15121	1
25	PHILLIPS HD MACH SCREW	21771-551	-----	4
26	FLATWASHER	K#08	15991	4
27	PHILLIPS HD MACH SCREW	21771-553	-----	2
28	OVERLOAD UNIT	27541-104	-----	1
29	PHILLIPS HD MACH SCREW	21771-552	-----	2
30	FT #10 AWG TEW/AWM BLK	18162-043	-----	1
31	FT #10 AWG TEW/AWM WHT	18162-041	-----	1
32	START RELAY	9483	-----	1
33	PHILLIPS HD MACH SCREW	21771-551	-----	1
34	FT #14 AWG TEW/AWM RED	18162-022	-----	1
35	FEMALE CONNECTOR	27236-052	-----	2
36	FT #14 AWG TEW/AWM BLK	18162-023	-----	1
37	FT #14 AWG TEW/AWM ORG	18162-026	-----	1
38	START CAPACITOR	9482A	-----	1
39	START CAPACITY BRACKET	27581-901	-----	1
40	CAPACITOR CAP	27588-014	-----	1
41	FLAT PH HD MACH SCREW STL	CG#10-01 1/2S	15991	2
42	FT #14 AWG TEW/AWM WHT	18162-021	-----	1
43	FEMALE CONNECTOR	27236-043	-----	3

OPERATION

OPERATION - SECTION C

CONTROL BOX FUNCTION

WARNING

```

////////////////////////////////////
//
// This pump motor and control box are not designed to be //
// explosion proof. Do not operate in an explosive atmos- //
// phere. //
// //
////////////////////////////////////

```

A control box is provided to facilitate operation of the pump. It contains controls for starting and stopping the pump, and provides overload protection for the pump motor. The pump control may be equipped with an optional automatic liquid level sensing device, in which case the low voltage circuits are also contained within the control box.

WARNING

```

////////////////////////////////////
//
// The pump motor is designed to be operated through the //
// control box furnished with the pump. The control box //
// provides overload protection and power control. Do not //
// connect the pump motor directly to the incoming power //
// lines. //
// //
////////////////////////////////////

```

CAUTION

Since operation of the pump motor is dependent upon the quality and performance of the electrical controls, the pump warranty is valid only when controls have been specified or provided by the Gorman-Rupp Company.

Component Function

The control box contains the following hand operated switches and controls:

- The **tie handle** operates the control box overload unit. In the OFF position, the tie handle opens the overload unit to interrupt incoming power through the control box and prevent pump operation. In the ON position, it closes the overload unit to permit pump operation. The overload unit will open or "TRIP" automatically in the event of a short circuit overload current, or thermal excess within the pump motor or electrical system. When tripped, move the tie handle to OFF and back to ON to reset the overload unit.



OPERATION

- The **selector switch** (optional on some boxes) controls the mode of operation. In the OFF position, it prevents all operation of the pump. In the HAND position, it allows the pump to run continuously. In the AUTO position, it allows the pump to be controlled automatically by the optional liquid level control system, if used.

NOTE

If the overload unit trips, do not reset it immediately. Wait at least ten minutes before resetting the tie handle back to the ON position. If the overload unit continues to trip, operational problems exist. See TROUBLESHOOTING.

WARNING

```

////////////////////////////////////
//
// The motor will restart as soon as the tie handle is re- //
// set, unless the selector switch is in the OFF position. //
// Turn the selector switch to OFF and move the tie handle //
// to OFF before approaching the pump. //
// //
////////////////////////////////////

```

- The **liquid level devices** (optional equipment) operate in conjunction with the 3-position switch (HAND-OFF-AUTO) supplied as a part of that option. After the level sensors and circuitry have been installed, pump operation may be automatically controlled for filling or dewatering functions. (See LIQUID LEVEL DEVICES, Section B.)

PUMP OPERATION

WARNING

```

////////////////////////////////////
//
// This pump is designed to handle most nonvolatile and //
// nonflammable liquids which may be mildly corrosive or //
// abrasive. Do not attempt to pump liquids which may //
// damage the pump or endanger personnel as a result of //
// pump failure. //
// //
////////////////////////////////////

```

Liquid Temperature And Overheating

The **maximum** liquid temperature for this pump is 120°F. Do not apply it at a higher operating temperature.

Overheating can occur if the pump is misapplied, required to start repeatedly, or if the control box fails to provide adequate protection. Operating the pump

OPERATION

against a closed discharge for extended period will also cause the pump to over-heat.

As a safeguard against rupture or explosion due to heat, this pump is equipped with a pressure relief valve which will open if vapor pressure within the pump motor reaches a critical point. If overheating does occur, stop the pump immediately and allow it to cool before servicing it. **Approach any overheated pump cautiously.**

**WARNING**

```

////////////////////////////////////
//
// Overheated pumps can cause severe burns and injury. If //
// overheating of the pump occurs:                          //
//
// 1. Stop the pump immediately.                             //
// 2. Allow the pump to cool.                                //
// 3. Refer to instructions in this manual before re-      //
// starting the pump.                                        //
//
////////////////////////////////////

```

It is recommended that the pressure relief valve assembly be replaced at each overhaul, or any time the pump motor overheats and activates the valve. **Never** replace this valve with a substitute which has not been specified or provided by the Gorman-Rupp Company.

**Checking Pump Rotation**

Check the direction of pump rotation before operation to ensure that the impeller is rotating in the correct direction.

Suspend the pump from the hoisting bail. Turn it on momentarily and note the direction of twist. For correct rotation and operation, the twist must be in the **counterclockwise** direction when viewed from the **top**.

**CAUTION**

<p>Secure the pump during rotation check to prevent coiling of the power cable.</p>
---

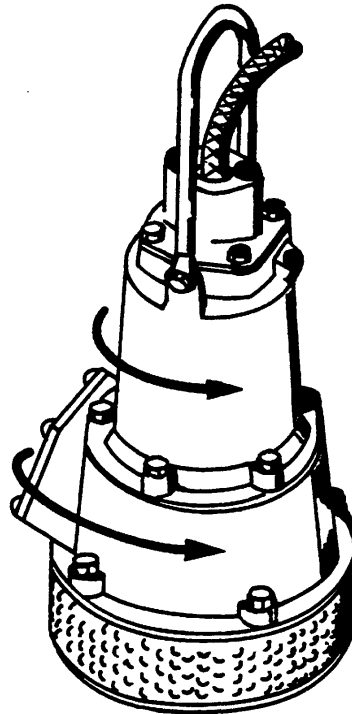

Figure 1. Checking Pump Rotation

If the pump twists clockwise on start, the pump must be returned to the factory or a Gorman-Rupp authorized Submersible Repair Center. Since this pump is driven by a single phase motor, the direction of rotation **can not** be altered by interchanging motor leads at the control box.

## STARTING

After the pump and control box have been installed, start the pump as follows.

### NOTE

Before actual operation, check the direction of impeller rotation to ensure that the pump is properly wired. See **Checking Pump Rotation** in **OPERATION** section.

### CAUTION

Never start the pump more than 6 times per hour. If the motor does not cool between starts, it will overheat resulting in damage to the motor windings and shaft bearings.

---

---

### Standard Pump (No Liquid Level Devices)

If no liquid level devices have been installed, move the tie handle to the ON position. The pump motor will start and pumping should begin. Since the pump is submerged, priming is not required.

The pump will continue to operate until it is stopped by turning the tie handle to OFF.

### With Automatic Liquid Level Devices

If optional liquid level devices have been installed, move the 3-position selector switch to OFF and the tie handle to the ON position.

If desired to operate the pump in the manual mode, set the selector switch to HAND; the pump will continue to run until the switch is returned to OFF, or reset to AUTO.

If desired to operate the pump in the automatic mode, set the selector switch to AUTO; pump operation will be maintained by the optional liquid level control system. To terminate automatic mode, move the selector switch to OFF or HAND.

### STOPPING

To stop pump operation, turn the tie handle OFF.

Power going to the pump from the control box is terminated by moving the tie handle to the OFF position, thereby opening the overload unit. This **does not** terminate incoming power through the field wiring connected to the control box.

After stopping the pump, be sure to perform all required maintenance and preservation procedures.

### NOTE

It is recommended that a check valve or throttling valve be installed in the discharge line if there is any possibility of siphoning or back flow when the pump is shut off.

### Operation Checks

Check the pump for proper operation when it is first started and periodically thereafter to identify minor problems.

Check the pump for unusual noises or excessive vibration while it is operating. If noise or vibration is excessive, stop the pump and refer to the troubleshooting chart for possible causes.

Check the pump strainer screen for clogging caused by stones, sticks, or other debris. Clean the strainer screen when required. In some cases, stopping the

OPERATION

pump momentarily may back flush the strainer screen, purging most of the debris from it. If this fails to clean the screen, remove the pump from the sump and remove the debris manually. See PUMP DISASSEMBLY.

Never introduce air or steam pressure into the pump casing or piping to remove a blockage. This could result in personal injury or damage to the equipment. If backflushing is absolutely necessary, liquid pressure must be limited to 50% of the maximum permissible operating pressure shown on the pump performance curve.

Check the pump for overheating. The pump could overheat if operated against a closed discharge valve, or subjected to repeated start cycles.

Cold Weather Preservation

In freezing temperatures, the pump will not freeze as long as it is submerged in liquid. If the pump casing is not submerged, or if the liquid begins to freeze, remove the pump from the sump or wet well and allow it to dry thoroughly. Run the pump for two or three minutes to dry the inner walls.

If the pump freezes, move it into a warm area until completely thawed, or submerge it into the liquid. If the liquid is near freezing, the pump must be submerged for an extended period of time. Start the pump and check for shaft rotation. If still frozen, allow additional thawing time before attempting to restart.

WARNING

Do not attempt to thaw the pump by using a torch or other source of flame. This could damage gaskets or heat the oil within the pump above the critical point and cause the pump to rupture or explode.

TROUBLESHOOTING - SECTION D

WARNING

```

////////////////////////////////////
//
// The electrical power used to operate this pump is high //
// enough to cause injury or death. Obtain the services of //
// a qualified electrician to troubleshoot, test and/or //
// service the electrical components of this pump. //
//
////////////////////////////////////
    
```

Many of the probable remedies listed in the troubleshooting chart below require use of electrical test instruments; for specific procedures, see **Electrical Testing** at the end of the troubleshooting chart.

TROUBLESHOOTING CHART

TROUBLE	POSSIBLE CAUSE	PROBABLE REMEDY
PUMP FAILS TO START, OVERLOAD UNIT NOT TRIPPED (MANUAL MODE)  (AUTOMATIC MODE)	Power source incompatible with control box.	Correct power source.
	No voltage at line side of overload unit.	Check power source for blown fuse, open overload unit, broken lead, or loose connection.
	Open circuit in motor windings or power cable.	Check continuity.
	Defective motor power cable.	Replace cable.
	Motor defective.	Check for and replace defective unit.
	Liquid level device or control circuits improperly connected to main control box.	Check wiring diagrams; correct or tighten connections.
	Level sensing device(s) improperly positioned.	Position device(s) at proper level.
Level sensing device(s) fouled with mud or foreign material.	Clean sensing device(s).	

TROUBLE	POSSIBLE CAUSE	PROBABLE REMEDY
PUMP FAILS TO START, OVERLOAD UNIT NOT TRIPPED (AUTOMATIC MODE) (cont.)	<p>Float type sensing device(s) tangled or obstructed.</p> <p>Defective liquid level sensing device(s) or control panel.</p>	<p>Check installation for free movement of float.</p> <p>Repair or replace defective unit(s).</p>
OVERLOAD UNIT TRIPS	<p>Low or high voltage, or excessive voltage drop between pump and control box.</p> <p>Defective insulation in motor windings or power cable; defective windings.</p> <p>Impeller jammed due to debris or insufficient clearance.</p> <p>Bearing(s) frozen.</p> <p>Terminal housing incorrectly wired. (Dual voltage or single phase motors only).</p>	<p>Measure voltage at control box. Check that wiring is correct type, size, and length. (See Field Wiring Connection, Section B).</p> <p>Check insulation resistance; check continuity.</p> <p>Disassemble pump and check impeller.</p> <p>Disassemble pump and check bearing(s).</p> <p>Check terminal housing internal connections against motor wiring plate and schematic wiring diagram.</p>
MOTOR RUNS, BUT PUMP FAILS TO DELIVER RATED DISCHARGE	<p>Discharge head too high.</p> <p>Low or incorrect voltage.</p> <p>Discharge throttling valve partially closed; check valve installed improperly.</p> <p>Discharge line clogged or restricted; hose kinked.</p> <p>Liquid being pumped too thick.</p> <p>Strainer screen or impeller clogged.</p>	<p>Reduce discharge head, or install staging adaptor and additional pump.</p> <p>Measure control box voltage, both when pump is running and when shut off.</p> <p>Open discharge valve fully; check piping installation.</p> <p>Check discharge lines; straighten hose.</p> <p>Dilute liquid if possible.</p> <p>Clear clog(s). Stop pump; back flow may flush away debris.</p>

TROUBLE	POSSIBLE CAUSE	PROBABLE REMEDY
MOTOR RUNS, BUT PUMP FAILS TO DELIVER RATED DISCHARGE (cont.)	Insufficient liquid in sump or tank.  Worn impeller vanes; excessive impeller clear- ance.  Pump running backwards.	Stop pump until liquid level rises.  Check impeller and clearance. See PUMP END REASSEMBLY.  Return pump to factory or author- ized Gorman-Rupp Submersible Re- pair Center.
PUMP RUNS WITH EXCES- SIVE NOISE OR VIBRATION	Pumping entrained air.  Damaged or unbalanced impeller.  Discharge piping not properly supported.  Impeller jammed or loose.  Motor shaft or bearings defective.  Pump cavitation.	Check liquid level in sump; check position of pump and liquid level sensing device(s).  Replace impeller.  Check piping installation.  Check impeller.  Disassemble pump and check motor and bearings.  Reduce discharge head, or restrict flow on low head appli- cations.



ELECTRICAL TESTING

If you suspect that pump malfunctions are caused by defects in the motor, power cable or control box, perform the following checks to help isolate the defective part.

WARNING

```

////////////////////////////////////
//
// The electrical power used to operate this pump is high //
// enough to cause injury or death. Obtain the services of //
// a qualified electrician to troubleshoot, test and/or //
// service the electrical components of this pump. //
// //
////////////////////////////////////

```

CAUTION

<p>Be certain to refer to the wiring diagram(s) in the INSTALLATION section of this manual before reconnecting any electrical components which have been disconnected.</p>
--

Test Equipment

A volt/amp/ohmmeter and megohmmeter of adequate range and quality will be required to conduct the following electrical tests. The suggested equipment indicated below is commercially available, or an equivalent substitute may be used.

Equipment	Manufacturer	Use
Amprobe Model 300 or Amprobe, Jr.	Pyramid Instrument Corp. Lynbrook, NY	To check AC Voltage and current (amperage)
Megohmer	Herman H. Sticht Co. 25 Bark Place New York, N.Y.	To measure resistance (ohms) to ground

Motor And Motor Power Cable Continuity

To check continuity, zero-balance the ohmmeter set at the RX1 scale, and test as follows:

- a. Disconnect the motor power cable leads from the control box and connect the test leads to any two of the three power cable leads (not to the green ground lead). If there is a high resistance reading on the

## TROUBLESHOOTING

---

---

ohmmeter, there is an open or broken circuit caused by a break in the power cable or motor windings, or by a bad connection between the motor and the power cable. Switch one test lead to the third power lead, and test again.

- b. If an open or broken circuit is indicated, check the power cable for obvious damage, and replace as necessary (see **MAINTENANCE AND REPAIR**). If there is no apparent damage to the motor cable, remove the terminal housing (see **MAINTENANCE AND REPAIR**) and check the continuity of each power cable lead at the terminal posts.

## NOTE

When shipped from the factory, the connections between the power cable leads and terminals were encapsulated in heat-shrink tubing, and bonded to the terminal plate with hot-melt adhesive to provide a water-tight seal. In service, these connections may have been potted by the pump operator. **Do not** cut the adhesive, tubing or potting away unless absolutely necessary. Check the continuity of each lead from the **motor** side of the terminal plate. If the continuity is good, there is no need to remove the sealing material. If there is no continuity through the lead, remove the sealing material from around **only** that terminal, and check for a loose connection. It is not necessary to remove the tubing from around the terminal unless the terminal requires replacement. **Be sure** to replace the adhesive or potting and allow adequate drying time before putting the pump back into service. (See **Power Cable Reassembly**, Section E.)

- c. If an open circuit still exists after each lead (terminal) has been tested and tightened, then the **entire** motor power cable must be replaced. Splicing or other means of repair are not recommended.
- d. If no break is found in the power cable, check the motor leads for continuity. If the test reading indicates an open or broken circuit, there is an open circuit in the motor.

## NOTE

It is recommended that a pump with a defective motor be returned to Gorman-Rupp, or to one of the Gorman-Rupp authorized Submersible Repair Centers.

## Insulation Resistance

To check insulation, zero-balance the ohmmeter set at the RX100K scale, and test as follows:

- a. Disconnect the motor power cable leads from the control box. Connect one test lead to the power cable green ground lead, and touch the other test lead to each of the three power leads in turn.

- 
- 
- b. The reading obtained will indicate resistance values in both the power cable and the motor windings. If the resistance reading is infinity ( $\infty$ ), the insulation is in good condition. If the reading is between infinity ( $\infty$ ) and 1 megohm, the insulation is acceptable but should be rechecked periodically. If the reading is less than 1 megohm, the insulation should be checked more closely; a reading of zero indicates that the power cable or the motor is grounded.
  - c. To determine whether the power cable or the motor is grounded, remove the terminal housing (see **MAINTENANCE AND REPAIR**), disconnect the motor leads from the motor terminals, and test the power cable leads and motor leads separately.

### Capacitors

The start capacitor is designed to split the electrical phase during the initial power surge at motor startup. The start capacitor is controlled by the start relay at motor startup. When the motor reaches load speed, the start relay cuts out and permits the run capacitor to maintain operation. Both the start and run capacitors are located in the control box.

#### CAUTION

Before disconnecting the capacitor leads, discharge the capacitors; use a screwdriver with an insulated handle, and place the blade across the two terminals of each capacitor to short the terminals.

Zero-balance the ohmmeter set to read RX100K, and test the capacitors as follows:

- a. Disconnect the capacitor leads, and remove the resistor from the start capacitor.
- b. Place a test lead against each of the terminals of the start capacitor for a few seconds. If the ohmmeter needle moves toward zero then slowly drifts back to the left, the capacitor is good. If the needle remains at infinity ( $\infty$ ) the capacitor is open; if the needle remains at zero, the capacitor is shorted. In either case, the capacitor must be replaced.
- c. Test the run capacitor as in b. In addition, test the metal run capacitor for shorts to ground by touching one test lead to the capacitor case and the other lead to each of the capacitor terminals in turn. The ohmmeter should read infinity ( $\infty$ ); if it does not, the capacitor is grounded and must be replaced.

### Start Relay

The start relay is located in the control box.

Disconnect the two wires from relay terminal 2. Use a zero-balanced ohmmeter set to read RX100K, and touch one lead to relay terminal 2 and the other to relay terminal 5. The resistance reading should be between 4000 to 6000 ohms; if the reading is not in this range, the start relay is defective and should be replaced.

#### NOTE

With the exception of the motor assembly, repair of individual electrical components is not recommended. Replace defective and/or malfunctioning components.



MAINTENANCE AND REPAIR - SECTION E

MAINTENANCE AND REPAIR OF THE WEARING PARTS OF THE PUMP WILL MAINTAIN PEAK OPERATING PERFORMANCE.

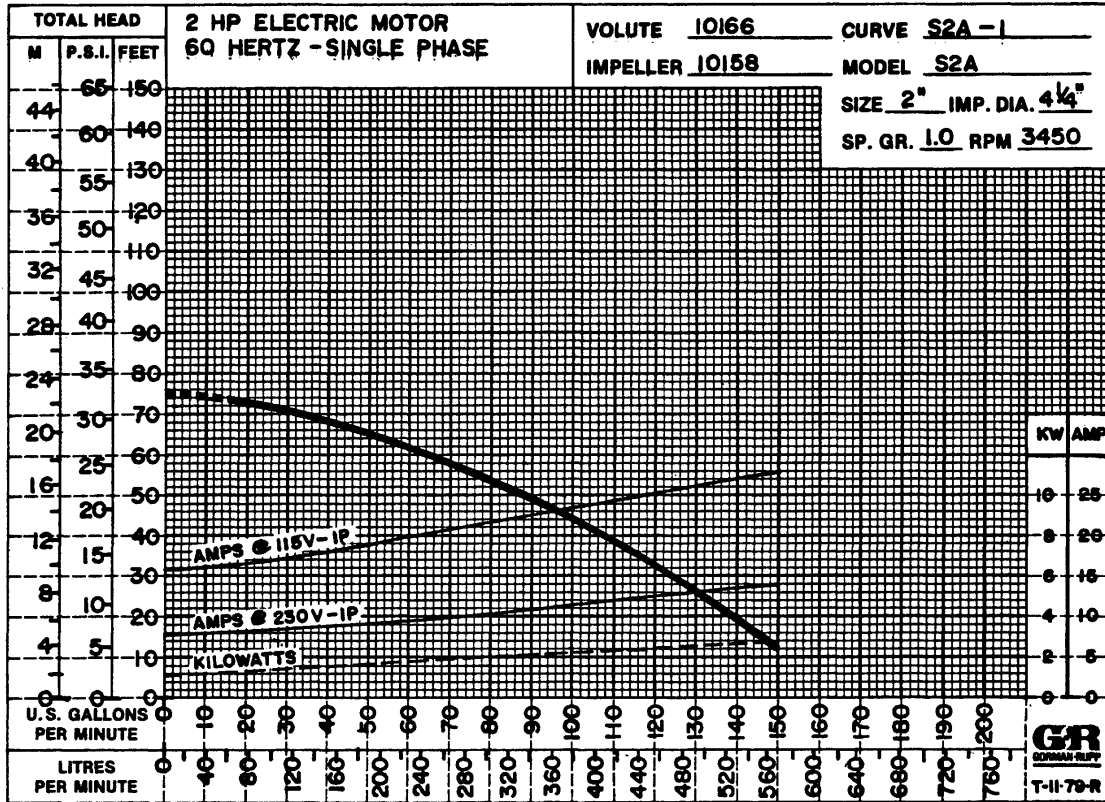

\*STANDARD PERFORMANCE FOR PUMP MODEL S2A1 230V 1P

\*Based on 70°F clear water at sea level. Since pump installations are seldom identical, your performance may be different due to such factors as viscosity, specific gravity, elevation, temperature, and impeller trim.

If your pump serial number is followed by an "N", your pump is NOT a standard production model. Contact the Gorman-Rupp Company to verify performance or part numbers.

SECTIONAL DRAWING

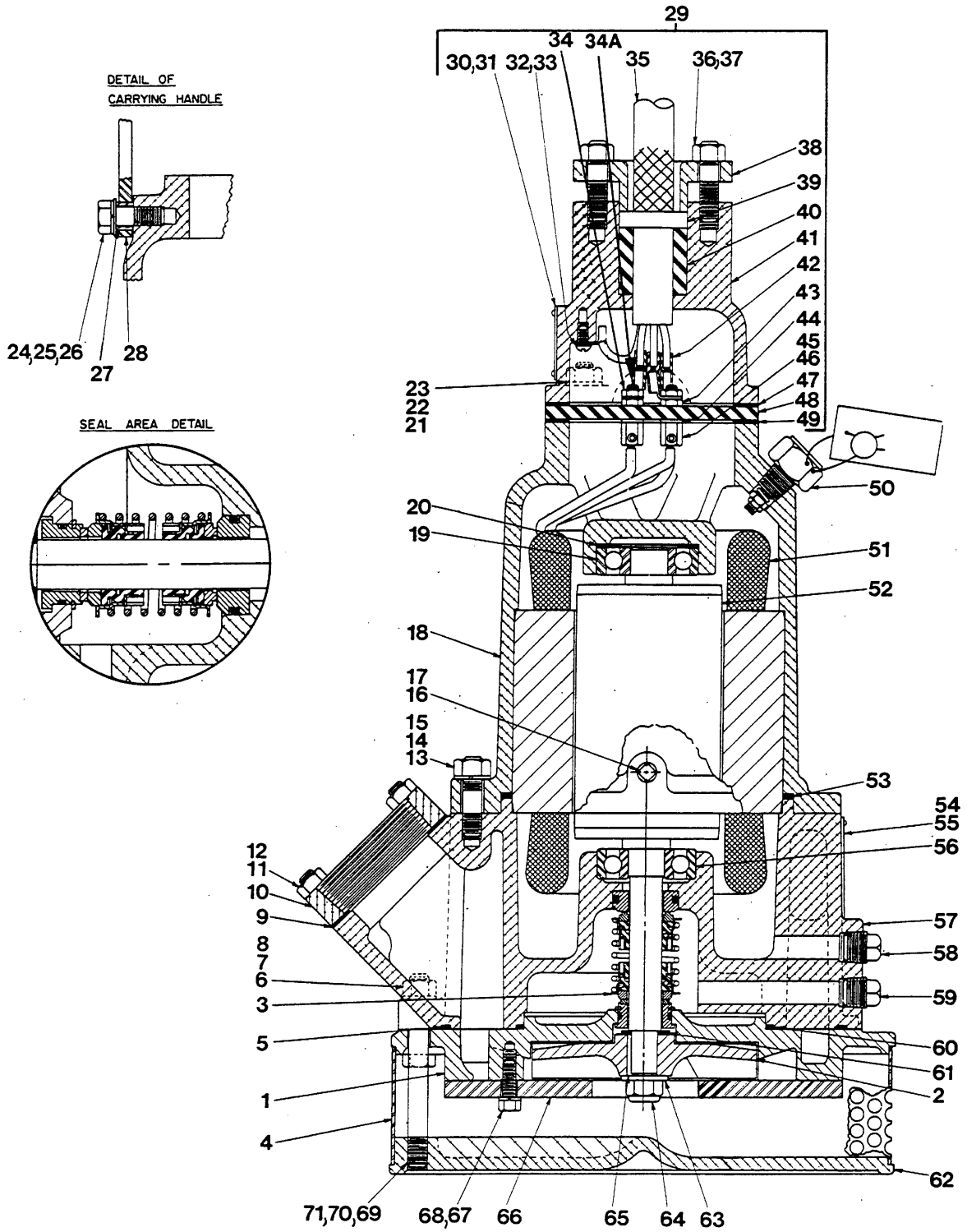

Figure 1. Pump Model S2A1-230V 1P

**PARTS LIST**  
**Pump Model S2A1 230 1P**  
 (From S/N 831598 up)

If your pump serial number is followed by an "N", your pump is NOT a standard production model. Contact the Gorman-Rupp Company to verify part numbers.

ITEM NO.	PART NAME	PART NUMBER	MAT'L CODE	QTY	ITEM NO.	PART NAME	PART NUMBER	MAT'L CODE	QTY
1	DIFFUSER	10166	11030	1	48 *	-TERM PLATE	10320A	23010	1
2 *	IMPELLER	10158	1100H	1	49 *	-LOWER TERMINAL	10321G	20000	1
3 *	SEAL ASSY	10214	-----	1		PLATE GKST			
4 *	STRAINER SCREEN	10189	1500V	1	50 *	RELIEF VALVE ASSY	46431-608	-----	1
5 *	INTERM OUTER GSKT	10181G	20000	1	51	STATOR ASSY	47113-802	-----	1
6	HEX HD CAPSCREW	B0606	15991	3	52	ROTOR ASSY	47112-801	-----	1
7	HEX NUT	D06	15991	3	53 *	MOT HOUSING GSKT	10178G	20000	1
8	LOCKWASHER	J06	15991	3	54	NAME PLATE	2613-CS	17020	1
9 *	DISCH FLANGE GSKT	10195G	20000	1	55	DRIVE SCREW	BM#04-03	17000	4
10	DISCHARGE FLANGE	10195	13040	1	56 *	LOWER BALL BRG	S1512	-----	1
11	STUD	C0506	15991	4	57	INTERMEDIATE	10181	13040	1
12	HEX NUT	D05	15991	4	58	MTR HSG DRAIN PLUG	P04	17000	1
13	STUD	C0606 1/2	15991	6	59	SEAL CAVITY	P04	17000	1
14	HEX NUT	D06	15991	6		DRAIN/FILL PLUG			
15	LOCKWASHER	J06	15991	6	60 *	INTERM INNER GSKT	10308G	20000	1
16	PIPE PLUG	P02	17000	1	61	IMP ADJ SHIM SET	669	14990	1
17	AL HD CAPSCREW	GA0503	15990	1	62	BASE PLATE	10186	13040	1
18	MOTOR HOUSING	10178	13040	1	63	IMP WASHER	KB06	17000	1
19 *	UPPER BALL BRG	S1512	-----	1	64	IMPELLER NUT	D06	17000	1
20	BRG SPRING WASHER	S1554	-----	1	65 *	IMPELLER KEY	N0202 1/2	17000	1
21	STUD	C0506	15991	4	66 *	WEAR PLATE	10161	15010	1
22	HEX NUT	D05	15991	4	67	HEX HD CAPSCREW	B0403	17000	3
23	LOCKWASHER	J05	15991	4	68	LOCKWASHER	J04	17090	3
24	HEX HD CAPSCREW	B0604	15991	2	69	STUD	C0614 1/2	15991	3
25	LOCKWASHER	J06	15991	2	70	HEX NUT	D06	15991	3
26	FLAT WASHER	K06	15991	2	71	LOCKWASHER	J06	15991	3
27	BUSHING	10194	15071	2					
28	HOISTING BAIL	10185A	1502V	1					
29	TERMINAL HOUSING & CABLE ASSY	47367-048	-----	1	NOT SHOWN:				
30	-INFORMATION PLATE	38816-047	17990	1		CABLE TIE	27111-212	-----	1
31	-DRIVE SCREW	BM#04-03	17000	4		CONTROL BOX ASSY	47631-124	-----	1
32	-RD HD MACH SCREW	X#10-01 1/2	14990	1		SUBMERSIBLE PUMP	9568	-----	1
33	-T-TYPE LOCKWASHER	AK#10	15991	1		OIL - 1 QT			
34	-HEX NUT	D#10	14990	3		IMPRLLRT PULLER	10770	-----	1
34A	-SEALANT RESERVOIR	31143-090	19220	1		SEAL INSTALL TOOL	10876	14090	1
35 *	-CABLE ASSY	10551A	-----	1		MTR VOLT TAG	38816-098	-----	1
36	-STUD	C0606	15991	2		HOT MELT ADHESIVE	18661-045	-----	2oz
37	-HEX NUT	D06	15991	2	OPTIONAL:				
38	-TERMINAL GLAND	10756C	13040	1		REPAIR GASKET KIT	11000A	-----	1
39 *	-CABLE GRIP	11227A	-----	1		HEAT SHRINK TUBE	48315-008	-----	1
40 *	-GLAND BUSHING	10758H	19100	1		TERM KIT			
41	-TERMINAL HOUSING	10757	13040	1		POTTING KIT	12442-B	-----	1
42	-HEAT SHRINK TUBE	31411-203	19530	3		TERMINAL HOUSING & 75' CABLE ASSY	47367-044	-----	1
43	-HEX NUT	D#10	14990	3					
44	-DYNA-SEAL WASHER	S1590	-----	3	LIQUID LEVEL DEVICES:				
45	-TERMINAL POST	11181	14100	3		DIAPHRAGM TYPE	GRP48-03 OR GRP48-06		1
46	-RD HD MACH SCREW	GA#10-01S	15991	3		FLOAT SWITCH	27471-180	-----	1
47 *	-UPR TERM PL GSKT	10321G	20000	1		120V CONTROL SW	47631-070	-----	1

\* INDICATES PARTS RECOMMENDED FOR STOCK  
 Above Serial Numbers Do Not Apply To Pumps Made In Canada.  
 CANADIAN SERIAL NO. .... AND UP



---



---

## PUMP AND MOTOR DISASSEMBLY AND REASSEMBLY

The following maintenance and repair instructions are keyed to the sectional view (see Figure 1) and the accompanying parts list.

### WARNING

```

////////////////////////////////////
//
// The electrical power to operate this pump is high enough //
// to cause injury or death. Make certain that the tie //
// handle on the control box is in the OFF position and //
// locked, or that the power supply to the control box has //
// been otherwise cut off and locked out, before attempting //
// to open or service the pump assembly. Tag electrical //
// circuits to prevent accidental start-up. //
// //
////////////////////////////////////

```

Before attempting to service the pump or control, cut off the power supply to the control box and close any valves in the discharge line.

### WARNING

```

////////////////////////////////////
//
// Do not attempt to lift the pump by the motor power cable //
// or the piping. Attach proper lifting equipment to the //
// lifting device fitted to the pump. If chains or cable //
// are wrapped around the pump to lift it, make certain //
// that they are positioned so as not to damage pump, and //
// so that the load will be balanced. //
// //
////////////////////////////////////

```

Use the hoisting bail to lift the pump from the wet well to a location where the discharge line can be removed. It is not necessary to disconnect a flexible discharge hose before removing the pump. If rigid discharge piping is used, disconnect the piping or the discharge flange (10) before attempting to remove the pump.

To remove the discharge flange, remove the nuts (12) securing the flange to the intermediate (57). Remove and discard the flange gasket (9).

Select a suitable location, preferably indoors, to perform the degree of maintenance required. If the motor housing is to be opened, the work must be done in a clean well-equipped shop. All maintenance functions must be performed by qualified personnel.

Check the chart in **TROUBLESHOOTING** to determine the nature of the pump problem. If the problem is mechanical in nature, such as worn pump parts, seal replacement, lubrication, etc., refer to **PUMP END DISASSEMBLY** for instructions.

If the problem is electrical, complete disassembly of the pump may not be required. Refer to **Electrical Testing** and have a qualified electrician check out control box, cable and terminal housing assembly. If problem is determined to be in the motor, proceed with **PUMP END DISASSEMBLY** followed by **MOTOR DISASSEMBLY**. Otherwise, see **Control Box and Terminal Housing/Power Cable Disassembly**.

---

---

All gaskets and most O-rings **must** be replaced if disturbed. A repair gasket kit is listed on the parts list as an option.

## PUMP END DISASSEMBLY

### Strainer And Wear Plate Disassembly

To remove the strainer screen (4) and base plate (62) raise the pump slightly or lay it on its side and remove the hardware (69, 70 and 71) securing the screen and base plate to the intermediate (57).

To remove the wear plate (66), remove the hardware (67 and 68) securing it to the diffuser (1). If the impeller is clogged, the debris can usually be removed without further pump disassembly.

### Draining Oil From Seal And Motor

If any further disassembly is to be performed on the pump, the oil cavities must be drained.

#### CAUTION

Let the pump cool before removing the seal or motor cavity drain plug. Pressure built up within a hot pump could cause the oil to spray out when the plug is removed. Remove the plug slowly and permit pressure to vent to atmosphere.

Lay the pump on its side with the drain plugs (58 and 59) facing up, and clean any dirt from around the plugs. Remove the seal cavity drain plug (59) and install a short 1/4-inch NPT nipple in the hole. Tip the pump up and drain the seal oil into a **clean** container. Inspect it for water, dirt or cloudy condition which could indicate lower seal failure or poor gasket seal.

If motor problems are suspected, remove motor cavity drain plug (58) and use a short nipple to drain the oil into a **clean** container at this time. Inspect the oil for dark color which could indicate motor overheating, dirt or water contamination. The presence of dirt or water could indicate a breakdown in the waterproof integrity of the motor cavity, probably due to poor gaskets or seals.

### Positioning Pump For Disassembly

It is recommended that the pump be positioned upside down during disassembly. To hold the pump in the inverted position, rest it securely on blocks. Be careful not to damage the terminal housing/cable assembly (29) or pressure relief valve (50) while in this position. Use adequate equipment and personnel to

---

---

safely handle the pump until it is secured. If inverting the pump is not practical, lay the pump on its side and secure it.

### Impeller Disassembly

Wedge a piece of wood between the vanes of the impeller (2) to prevent shaft rotation.

Remove the impeller nut (64) and washer (63).

Remove the piece of wood from between the vanes of the impeller. Refer to Figure 2, install the impeller puller supplied with the pump, and pull the impeller from the shaft. Retain the impeller key (65).



Figure 2. Removing Impeller With Puller

Remove the impeller adjusting shims (61); for ease of reassembly, tie and tag the shims.

### Seal Disassembly

(Figure 1 and 3)

The seal used in this pump has two rotating elements, two stationary elements, and two bellows assemblies. The mating faces of the rotating and stationary elements are precision finished and subject to wear. The complete seal should be replaced with each overhaul to ensure trouble-free operation. However, if the old seal must be reused, wrap the seal faces individually in tissue paper to prevent damage to the sealing surfaces.

Disengage the hardware (6, 7, and 8) and separate the diffuser (1) from the intermediate (57). Use caution when removing this hardware; tension on the seal spring will be released.

The lower seal base ring is secured to the diffuser with a retaining ring. Place the diffuser on a level surface with the impeller side down, remove the retaining ring with a snap ring pliers, and press the base ring out of the diffuser.

---

---

Remove the lower seal stationary and rotating elements. Lubricate the exposed portion of the rotor shaft and work oil under the lower bellows assembly. Slide the lower bellows assembly off the shaft and remove the seal spring.

Work oil under the upper bellows assembly, and slide it off the shaft. Remove the upper seal rotating element. Slide two stiff wires with hooked ends along the shaft and under the upper stationary element. Hook the back side of the element and pull it out of the intermediate bore.

#### NOTE

Do not disassemble the motor unless it is necessary and a clean, well-equipped shop is available. If the motor housing components are to be serviced, see **MOTOR DISASSEMBLY** in this section. Do not reassemble the pump end components at this time.

If no further disassembly is required, proceed to appropriate areas in **PUMP END REASSEMBLY**.

#### PUMP END REASSEMBLY

#### NOTE

Reuse of old O-rings, gaskets, or shaft seal parts may result in premature leakage or reduced pump performance. It is strongly recommended that an overhaul gasket kit and new shaft seal assemblies be used during reassembly. (See the parts list for part numbers).

#### Cleaning Old Parts

With the pump inverted, stuff a clean tissue into the stationary bore of the intermediate (or wrap a small rag around the shaft) to prevent foreign material from entering the motor cavity.

Carefully inspect O-rings or gaskets before removal and cleaning to determine if a proper seal and compression existed prior to disassembly. If sealing was faulty or questionable, the cause must be determined and corrected before reassembly. Replace any parts required.

Thoroughly clean all reuseable parts. Remove all O-rings and gaskets and clean the sealing surfaces of dirt or gasket material. Be careful not to scratch gasket surfaces.

---



---

**WARNING**

```

////////////////////////////////////
//
// Most cleaning solvents are toxic and flammable. Use
// them only in a well-ventilated area free from excessive
// heat, sparks, and flame. Read and follow all pre-
// cautions printed on solvent containers.
//
////////////////////////////////////

```

The shaft seal assembly should not be reused because wear patterns on the finished faces cannot be realigned during reassembly. This could result in premature failure. If necessary to reuse an old seal in an emergency, **carefully** wash all metallic parts in fresh cleaning solvent and allow to dry thoroughly.

Handle seal parts with extreme care to prevent damage. Be careful not to contaminate precision finished faces; even fingerprints on the faces can shorten seal life. If necessary, clean the faces with a non-oil based solvent and a clean lint free tissue. Wipe **lightly** in a concentric pattern to avoid scratching the faces.

Inspect the seal components for wear, scoring, grooves, and other damage that might cause leakage. If any components are worn, replace the complete seal; **never** mix old and new seal parts.

Install the shaft seals as illustrated in Figure 3.

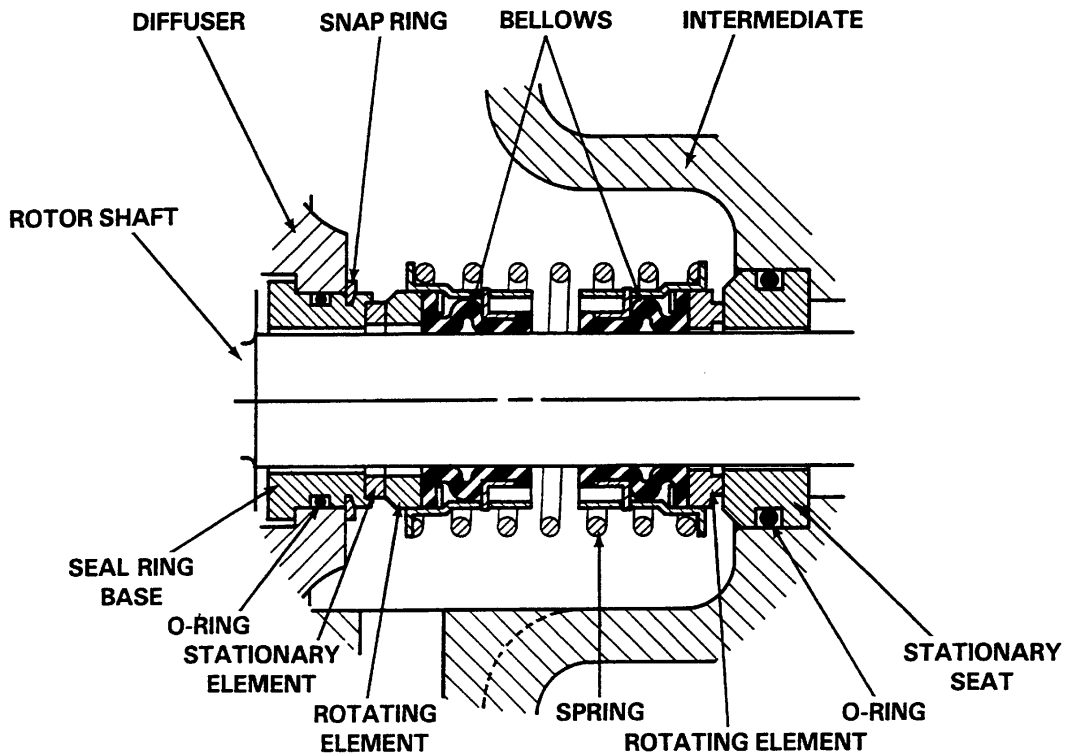

Figure 3. 10214 Seal Assembly

---

---

## Seal Reassembly

Clean the rotor shaft and inspect the end for damaged threads, scoring, and a nicked or damaged keyway. Remove nicks and burrs with a fine file or hand honing stone to restore original contours. If the shaft is bent or damaged, the complete shaft and rotor (52) must be replaced as an assembly (see **MOTOR DISASSEMBLY**).

If a new seal is to be installed, do not unwrap it until time of installation. Cleanliness of all seal components is a must, especially the seal faces.

Carefully remove the material stuffed into the seat bore (or unwrap the shaft). **Be sure** no debris stopped by the material falls into motor cavity.

Carefully clean the seal seat area in intermediate (57), and check for burrs or nicks that might cut the seal O-ring or prevent a good seal. Apply a **light** coating of oil to the bore.

### NOTE

When pressing seal components on the impeller shaft, use hand pressure only. A push tube cut from a length of plastic pipe will aid in installing seal components. The I.D. of the push tube should be approximately the same as the I.D. of the seal spring.

Unpack the upper seal stationary element and install the O-ring, taking care not to touch the sealing face. Apply a light coating of oil to the O-ring. Keep the sealing face dry.

Place a clean tissue over the seal face, and slide the stationary element onto the rotor shaft. Press the element into the bore of the intermediate until it bottoms. Remove the tissue and inspect the seal face to ensure that it is clean and dry. If cleaning is necessary, use clean tissue to wipe **lightly** in a concentric pattern.

Lightly oil the O.D. of the seal installation tool (P/N 10876) furnished with the pump, and install it over the threaded end of the shaft.

Unpack the upper seal rotating portion. Be certain the seal face of the rotating element is free of grit or surface damage. Assemble the drive grooves of the rotating element into the drive lugs of the bellows retainer.

Push the rotating element and bellows down over the installation tool and shaft with the seal face down. If the rotating element does not stay in the bellows retainer when turned upside down, place a **small** amount of grease at equal spaces on the back of the element and position it in the bellows retainer. The grease should hold the element in position until the seal is installed. Apply firm, steady pressure, with clean hands, on the seal retainer until the rotating element contacts the stationary element.

Drop the seal spring down over the bellows retainer.

Unpack the lower rotating portion and inspect the parts. Subassemble the drive grooves of the stationary element into the bellows retainer. Apply firm, steady pressure, with clean hands, on the seal retainer until it slides down the installation tool and past the shaft shoulder. Remove the installation tool while pressing the rotating element onto the shaft. Remove the tissue and inspect the

---

---

seal face to ensure that it is clean and dry. If cleaning is necessary, use clean tissue to wipe **lightly** in a concentric pattern.

#### NOTE

The seal spring will not fully compress until the diffuser (1) is installed.

Inspect the lower stationary element and slide it down the rotor shaft with the seal face down.

Clean the diffuser (1), and inspect it for cracked, distortion, and erosion. Replace if defective.

Unpack the lower seal base ring, and oil the O.D. of the O-ring. Carefully press the base ring in the diffuser, and secure it with the retaining ring. Do not force the retaining ring into position; cocking the ring may cause improper mating of the seal faces.

Clean the gasket grooves in the intermediate, and install the gaskets (5 and 60).

Coat the diffuser capscrews (6) with 'Never-Seez' or equivalent compound. Position the diffuser on the intermediate so that the bore of the seal base ring slips over the stationary seal element. **Be sure** the stationary element is fully seated before installing the lockwashers (8) and torquing the nuts (7) to 20 ft. lbs. (240 inch lbs.).

#### Impeller Reassembly

Install the same number of impeller adjusting shims (61) as originally removed.

Inspect the impeller (2), and replace if cracked or badly worn. Clean the threads on the rotor shaft to remove any old thread locking material.

Install the impeller key (65) in the rotor shaft keyway slide the impeller onto the shaft.

After the impeller has been installed, coat the threads of the rotor shaft with 'Loctite Threadlocker No. 242' or equivalent compound. Install the impeller washer (63) and nut (64). Place a block of wood between the vanes of the impeller to prevent shaft rotation, and torque the impeller nut to 20 ft. lbs. (240 inch lbs.).

Turn the impeller to check for free rotation.

Clean the contacting surfaces of the wear plate (66), and replace it if badly scored or worn. Coat the contacting surfaces of the wear plate with "3-M Sealer" or equivalent compound, and position the wear plate on the diffuser (1). Install the lockwashers (68) on the capscrews (67) and apply 'Never-Seez' or equivalent compound on the threads before torquing to 5 ft. lbs. (60 inch lbs.).

Impeller Clearance

There should be a clearance of .003 to .010 inch between the wear plate and the face of the impeller (2). Measure this clearance with a feeler gauge.

If the impeller clearance is not within specified limits, remove the wear plate and the impeller, then add or remove impeller adjusting shims (61) as required. Reinstall the impeller and wear plate, and recheck clearance.

Strainer Screen And Base Plate Reassembly

Inspect the strainer screen (4) and base plate (62) for cracks, broken welds and distortion, and replace if defective.

Position the strainer screen on the shoulder of the diffuser (1), and install the base plate. Check that the strainer screen seats properly against the shoulder of the base plate, and secure by tightening the hardware (69, 70 and 71).

See LUBRICATION and FINAL ASSEMBLY before putting the pump into service.

MOTOR DISASSEMBLY

Disassembly of the motor is rarely required except to replace the motor rotor, stator, bearings, or intermediate. Do not disassemble the motor unless it is necessary and a clean, well-equipped shop is available.

NOTE

It is recommended that a pump with a defective motor be returned to Gorman-Rupp, or to one of the Gorman-Rupp authorized Submersible Repair Centers.

WARNING

```

////////////////////////////////////
//                               //
// The electrical power to operate this pump is high enough //
// to cause injury or death. Make certain that the tie //
// handle on the control box is in the OFF position and //
// locked, or that the power supply to the control box has //
// been otherwise cut off and locked out, before attempting //
// to open or service the pump assembly. Tag electrical //
// circuits to prevent accidental start-up. //
//                               //
////////////////////////////////////

```

Carefully inspect any O-rings or gaskets before removal and cleaning to determine if a proper seal and compression existed prior to disassembly. If sealing was faulty or questionable, the cause must be determined and corrected before reassembly. Replace any parts as required.



---

---

### Terminal Housing/Power Cable Disassembly

If the pump is maintained in an upright position, the terminal housing/cable assembly (29) may be serviced without draining the oil from the motor cavity. However, the oil must be drained before attempting to disassemble the motor housing and components. To drain the oil, see **Draining Oil in PUMP END DISASSEMBLY**.

Total disassembly of the terminal housing and power cable is not always required. Disassemble and replace only the parts which have been proven defective by inspection or testing. See **Electrical Testing in TROUBLESHOOTING**.

The terminal housing/power cable assembly (29) may be serviced without disassembling the motor housing or pump end.

To remove the terminal housing (41), remove the hardware (22 and 23) securing the terminal housing to the motor housing (18). Raise the terminal housing and terminal plate for access to the motor terminal posts (45). Loosen the machine screws (46) and disconnect the motor leads from the terminal posts. Remove the terminal housing/cable assembly.

To separate power cable (35) from the terminal housing, remove the nuts (37) securing the terminal gland (38) to the terminal housing. Slide the gland back along power cable. Compress the wire mesh of the cable grip (39) and move it back along power cable. Oil the gland bushing (40) and terminal housing bore and pull firmly on the cable. (Allow the oil to leak in around the bushing by agitating the cable in the bore.) After the bushing has been loosened, the cable should pull out far enough to expose the gland bushing. Apply oil on the cable jacket and slide the bushing back along the cable. Quite often, pressure exerted on the bushing will deform the cable jacket. If such is the case, additional oil and effort will be required to remove the bushing.

#### NOTE

If the rubber bushing cannot be removed from the terminal housing as indicated, it may be necessary to cut the bushing into small pieces or cut the cable.

Push approximately 6 inches of the power cable into the terminal housing so that the terminal plate (48) comes free of the terminal housing. This should permit access to the power cable connections in the terminal plate.

To disconnect the power cable, remove the round head screw (32) and lockwasher (33) securing the green ground lead. When shipped from the factory, the connections between the power cable leads and terminals were encapsulated in heat-shrink tubing (42) and bonded to the terminal plate (48). (In service, the heat-shrink tubing may have been replaced by potting compound during previous repair.) Cut away the bonding adhesive (or potting) and remove the upper hex nuts (34). Disconnect the power cable leads from the terminal posts.

Pull the power cable out of the terminal housing. The gland bushing (40), cable grip (39) and terminal gland (38) can be removed from the cable.

It is not necessary to remove the heat-shrink tubing from the power cable leads unless the terminals require replacement. If replacement is required, carefully cut the tubing from around the leads and terminals.

---

---

If necessary to replace the terminal plate (48) or gaskets (47 and 49), unscrew the lower nuts (43) from the terminal posts (45) and remove the posts from the terminal plate. Discard the gaskets.

See **Terminal Housing/Power Cable Reassembly** if no further disassembly is required.

### Rotor Disassembly

See **Pump End Disassembly**, and remove all pump end seal components.

With the pump end disassembled and the motor cavity drained, secure the pump in an inverted position. Remove the hardware (14 and 15) securing the motor housing (18) to the intermediate (57). If necessary, tap around the parting surfaces with a soft faced mallet to break the seal between the intermediate and motor housing. Remove the intermediate, and discard the motor housing gasket (53).

Use caution to prevent the rotor (52) from falling on the stator windings. Carefully pull the rotor and assembled ball bearings (19 and 56) from the motor housing (18). Reach into the motor housing and remove the spring washer (20) from the upper bearing bore.

Use an arbor (or hydraulic) press to remove the lower and upper ball bearings (19 and 56) from the shaft.

### Stator Disassembly

It is recommended that the stator (51) be left in place unless it is defective. If the stator must be removed, disconnect the motor leads from the terminal posts (46) as indicated in **Terminal Housing/Power Cable Disassembly**.

Remove the pipe plug (16) located in the motor housing, and loosen the allen head setscrew (17) located underneath the plug.

With the pump end, intermediate and rotor removed, position an expandable tool, such as a split disc, approximately 2 inches down inside the stator, and expand it tightly and squarely on the I.D. Attach a lifting device to the center lifting eye of the tool and raise the assembly 1 inch from the surface. Take care not to damage the stator end turns. Use a soft-faced mallet to tap alternate edges of the motor housing (18), and "walk" the stator out. Continue this process until the stator clears the motor housing.

### NOTE

It may be necessary to heat the motor housing to permit stator removal.

After the stator has been removed, wrap it in clean dry rags or other suitable material. The stator **must** be kept clean and dry. When handling the stator, do not set it on the end windings; lay it on its side.

---

---

**CAUTION**

Do not attempt to rewind the stator. Winding tolerances and materials are closely controlled by the manufacturer, and any deviation can cause damage or operating problems. Replace the stator, or return it to one of The Gorman-Rupp Authorized Submersible Repair Centers or The Gorman-Rupp factory, if defective.

**Relief Valve****NOTE**

In Figure 1, the relief valve assembly (50) is shown rotated 90° from its actual position for clarity.

It is recommended that the relief valve assembly be replaced at each overhaul, or at any time the pump motor overheats and activates the valve. **Never** replace this valve with a substitute which has not been specified or provided by the Gorman-Rupp Company.

When installing the relief valve assembly, use "Loctite Pipe Sealant With Teflon No. 592", or equivalent compound on the threads.

**Hoisting Bail**

If the hoisting bail (28) requires replacement, remove the hardware (24, 25 and 26) securing the bail to the motor housing (18). Make certain that the bushings (27) are in place when installing the hoisting bail.

**MOTOR REASSEMBLY****NOTE**

Reuse of old O-rings, gaskets, or shaft seal parts may result in premature leakage or reduced pump performance. It is strongly recommended that an overhaul gasket kit and new shaft seal assembly be used during reassembly. (See the parts list for part numbers).

## Stator Reassembly

Clean all gasket and O-ring surfaces completely, removing any old gasket and cement material. Inspect the sealing surfaces for burrs, nicks, and pits which could cause a poor seal. Replace parts as required.

Thoroughly clean the inside of the motor housing (18) with fresh solvent. The interior **must** be dry and free of dirt or lint.

### WARNING

```

////////////////////////////////////
//
// Most cleaning solvents are toxic and flammable. Use //
// them only in a well-ventilated area free from excessive //
// heat, sparks, and flame. Read and follow all prec- //
// autions printed on solvent containers. //
//
////////////////////////////////////

```

Do not unwrap the stator until the motor housing has been prepared for stator installation. The stator **must** be kept clean and dry. When handling stator, do not set it on its end windings. Lay it on its side.

Test the new stator as indicated in **Electrical Testing** in **TROUBLESHOOTING** to ensure that no damage has occurred during handling.

Position an expandable tool, such as a split disc, approximately 2 inches from the end of the stator (opposite the lead wire end). Expand it tightly on the I.D. of stator. Carefully raise the stator with a lifting device attached to the center lifting eye of the tool. Take care not to damage the stator end turns. Slip a sleeve over the stator lead wires to prevent damage to them.

Invert the motor housing. Position the stator so that the leads are in line with the opening for the terminal housing, and carefully lower the stator into the motor housing. If the stator "cocks" in the motor housing, remove it and try again. If necessary, heat the motor housing with a torch to expand it enough for the stator to be installed; when heating the motor housing, **make certain** that the stator is clear to avoid damage to the windings. Apply heat evenly to the inside of the motor housing; excessive heat is not required. Be careful not to damage the stator lead insulation during reassembly.

After the stator is fully and squarely seated on the motor housing shoulder, remove the tool used for lifting, and tighten the allen head setscrew (17) securing the stator in place. Coat the threads of the pipe plug (16) with "Loctite Pipe Sealant With Teflon No. 592" or equivalent sealant, and install the plug over the allen head setscrew.

Cover the motor housing with a clean, lint-free cloth while the rotor is being assembled.

## Rotor Reassembly

Inspect the seal and bearing areas of the rotor shaft. Inspect the shaft for damaged threads, scoring, and a nicked or damaged keyway. Remove nicks and burrs with a fine file or honing stone. If the shaft is bent or damaged, replace the shaft and rotor (a single assembly).

Clean the bearings thoroughly in **fresh** cleaning solvent. Dry the bearings with filtered compressed air and coat with light oil.

**WARNING**

```

////////////////////////////////////
//
// Most cleaning solvents are toxic and flammable. Use //
// them only in a well-ventilated area free from excessive //
// heat, sparks, and flame. Read and follow all prec- //
// autions printed on solvent containers. //
//
////////////////////////////////////

```

Rotate the bearings by hand to check for roughness or binding and inspect the bearing balls. If rotation is rough or the bearing balls are discolored, replace the bearings.

**CAUTION**

<p>Bearings must be kept free of all dirt and foreign material. Failure to do so will greatly shorten bearing life. DO NOT spin dry bearings. This may scratch the balls or races and cause premature bearing failure.</p>
--

The bearing tolerances provide a tight press fit onto the shaft and a snug slip fit into the motor housing and intermediate. Replace the shaft and rotor (as an assembly), motor housing or intermediate if the proper bearing fit is not achieved.

Install the lower and upper ball bearings (19 and 56) on the rotor shaft. Make certain that they seat squarely against the shaft shoulders.

**CAUTION**

<p>When installing the bearings onto the shaft, NEVER press or hit against the outer race, balls, or ball cage. Press ONLY on the inner race.</p>
---

Clean the ball bearing bores and all gasket surfaces of the intermediate (57) and the motor housing (18), completely removing old gasket and cement material. Inspect the sealing surfaces for burrs, nicks and pits which could cause a poor seal. Repair or replace as required.

MAINTENANCE AND REPAIR

WARNING

```

////////////////////////////////////
//
// Most cleaning solvents are toxic and flammable. Use //
// them only in a well-ventilated area free from excessive //
// heat, sparks, and flame. Read and follow all prec- //
// autions printed on solvent containers. //
//
////////////////////////////////////

```

Install the spring washer (20) in the motor housing bore.

Carefully ease the rotor and assembled ball bearings through the stator until the upper bearing (19) is firmly seated in the motor housing bearing bore.

Replace the motor housing gasket (53). Use 'Never-Seez' or equivalent compound on the threads of the intermediate studs (13) and install the intermediate on the motor housing. Install the lockwashers (15) and nuts (14) on the intermediate studs; torque the nuts to 20 ft. lbs. (240 inch lbs.).

See PUMP END REASSEMBLY, and reassemble the pump end components.

Terminal Housing And Power Cable Reassembly

WARNING

```

////////////////////////////////////
//
// The electrical power used to operate this pump is high //
// enough to cause injury or death. Make certain that the //
// control handle on the control box is in the OFF position //
// and locked, or that the power supply to the control box //
// has been otherwise cut off and locked out. Tag elec- //
// trical circuits to prevent accidental start-up. Obtain //
// the services of a qualified electrician and refer to the //
// wiring diagrams in INSTALLATION to make all electrical //
// connections. //
//
////////////////////////////////////

```

WARNING

```

////////////////////////////////////
//
// Refer to the wiring diagrams in INSTALLATION when recon- //
// necting motor and power leads and power cable leads. //
//
////////////////////////////////////

```

Clean the exterior of the pump power cable with warm water and mild detergent, and check for obvious physical damage. Check the cable for continuity and insulation resistance (see Electrical Testing in TROUBLESHOOTING).

CAUTION

Do not attempt repairs except at either end of the power cable. Splicing is not recommended.

Lubricate the upper bore of the terminal housing (41), outside of the power cable (35), and bores of the terminal gland (38), cable grip (39) and gland bushing (40) for ease of assembly. Slide the terminal gland, cable grip, gland bushing, adhesive reservoir (or potting sleeve), and terminal housing on the power cable in that order (see Figure 1 to recheck order of assembly).

Work the cable components up the cable to allow approximately 3 ft. of cable to extend below the terminal housing. Temporarily tape the green ground wire to the cable.

Power Cable Potting

WARNING

Do not attempt to operate this pump unless the power cable terminals (except for the ground terminal) are properly potted or sealed with heat-shrink tubing and bonded to the terminal plate. Moisture entering the terminal housing could cause a short circuit, resulting in death or injury to personnel.

If the power cable terminals were removed from the leads, the connections must be resealed with a water-tight material such as electrical potting compound or heat-shrink tube.

When shipped from the factory, the cable leads and terminals were encapsulated in heat-shrink tubing (42) and bonded to the terminal plate (48) with hot-melt adhesive to provide a water-tight seal. These materials are included in an optional repair kit listed in the parts list; however, since a glue gun with the required temperature range is not generally available in the field, it is recommended that a repotting kit available from Gorman-Rupp (see optional equipment in parts list) or a commercially available kit (Products Research Corp., part no. PR-1201-A Class 1 potting compound, or equivalent) be used to reseat the connections. See Figure 4, and the following instructions.

NOTE

Potting compound and heat-shrink tubing have the same electrical properties when correctly applied. Heat-shrink tubing is used at the factory to ease production. The advantage of using potting compound for field repairs is greater availability, and elimination of special tools.

If heat-shrink tubing is used for field repairs, use **only** materials and heating equipment approved by Gorman-Rupp.

Clean and assemble all terminal components as indicated in the potting instructions.

If removed for replacement, crimp a new terminal on each power cable lead and slide a length of shrink tube (Gorman-Rupp part number 31411-203) over each terminal. The tubing should cover the crimped part of the terminals and extend up the leads far enough to ensure a good seal. Carefully heat each tube with a torch, or commercial hot air gun capable of producing 750° F (399° C), and shrink it around the cable leads and terminals.

After the tubing has shrunk and set, secure the terminals to the terminal posts (45) with the upper nuts (34). Slide the adhesive reservoir down the cable and center it around the terminals. Use a hot melt adhesive tool (Terlan TM-80, set at 450° F (232° C)) to apply adhesive (Gorman-Rupp part number 18661-045) over the terminal posts and around the base of the heat-shrink tubes to completely fill the reservoir and insulate the electrical connections.

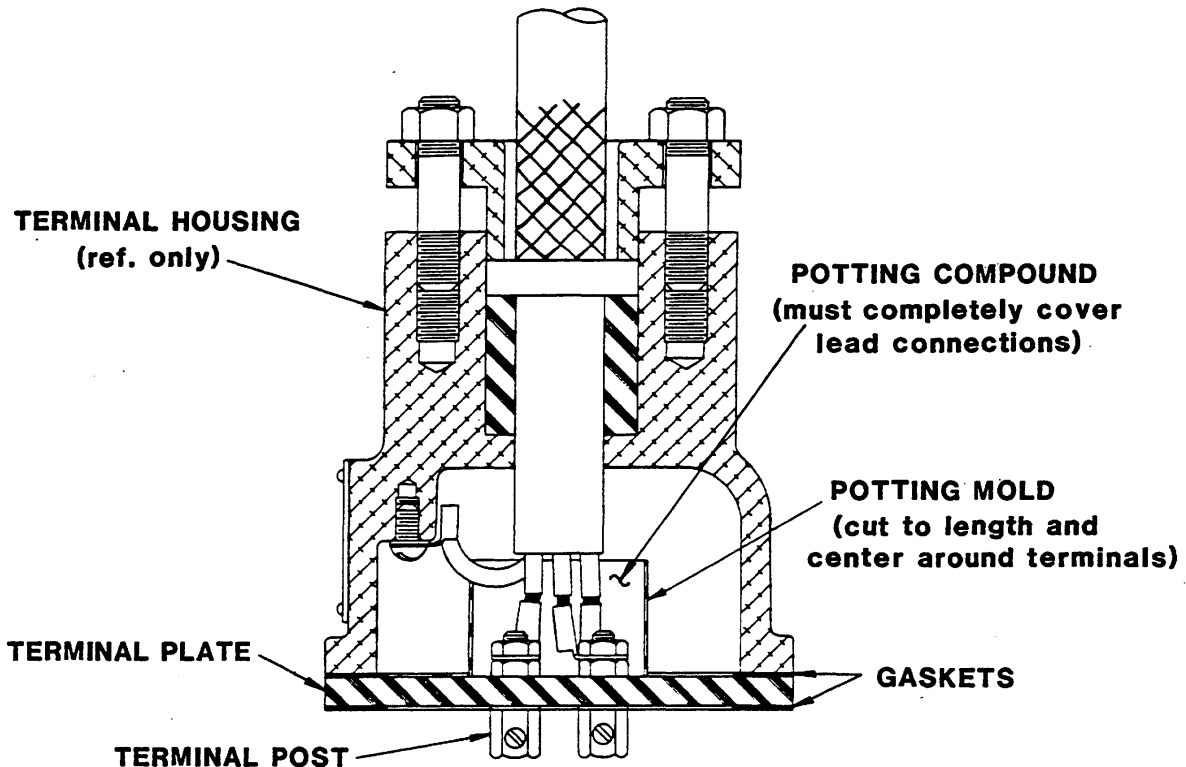

Figure 4. Potting Power Cable Leads In Terminal Housing

If the power cable is to be potted, a repotting kit is available from Gorman-Rupp (see parts list) as an option with this pump. Use this kit, or Products Research Corp. PR-1201-A Class 1 potting compound, or equivalent.



WARNING

```

////////////////////////////////////
//
// Do not attempt to operate this pump unless the power ca- //
// ble terminals (except for the ground terminal) are prop- //
// erly potted or sealed with heat-shrink tubing and bonded //
// to the terminal plate. Moisture entering the terminal //
// housing could cause a short circuit, resulting in death //
// or injury to personnel. //
// //
////////////////////////////////////

```

Remove all the old adhesive or potting compound from the terminal posts, nuts (34) and terminal plate (48). Inspect the terminal posts for damage, and replace as required. Use a medium-grit sandpaper to prepare the surface of the terminal plate in the area of the potting mold.

NOTE

Clean the cable leads and terminal plate in areas to be potted with cleaning solvent before potting. Potting compound will not adhere properly to oil or grease coated surfaces.

If the terminals were removed from the leads, crimp a new terminal onto each lead.

Assemble the terminal posts (45), dyna seal washers (44) and lower nuts (43) to the terminal plate (48).

Trim the potting mold so it is just long enough to cover the terminal post studs (see Figure 5). Slide the potting mold up over the three standard leads of the power cable (35).

Secure the three power leads on the terminal posts (45) with the upper nuts (34). Slide the potting mold down over the terminal posts and onto the terminal plate. Hang the cable in vertical position with terminal plate horizontal. The cable leads and terminal collars should be centered in potting mold. Use quick-setting cement, such as "3-M Weather Seal" to secure the potting mold to the terminal plate.

WARNING

```

////////////////////////////////////
//
// Most potting base compounds contain toluene; use ade- //
// quate ventilation and avoid prolonged breathing of va- //
// pors. Most potting accelerators contain lead; avoid //
// ingestion or prolonged contact with the skin. Read and //
// follow all warnings and recommendations accompanying the //
// potting kit. //
// //
////////////////////////////////////

```

See the instructions with the potting kit regarding application life, and setting and curing time. Mix the base compound and accelerator and fill the mold completely. Tamp the potting material to eliminate air bubbles and ensure the material has completely covered the area around the terminal posts.

---

---

**MAINTENANCE AND REPAIR**

---

---

When potting has been completed, leave the terminal plate assembly undisturbed until the potting material has cured. Complete curing usually takes about 24 hours. Curing time can be shortened by using a heat lamp, but be careful not to melt the potting or potting mold, or burn the cable. When potting material is no longer "tacky" to the touch, it has cured.

After the potting material has cured, untape the ground leads and slide the terminal housing down the cable. Secure the green ground lead with the machine screw and lockwasher (32 and 33). Make sure the lead makes good contact with the housing.

Pull gently on the power cable to remove any excess length from within the terminal housing. The terminal plate should fit loosely in the terminal housing.

Lubricate the upper bore of the terminal housing, and slide the gland bushing (40) into place. Compress the wire mesh of the cable grip (39) and slide it down the cable, making sure it comes in contact with the bushing. Slide the terminal gland (38) into place. Coat the threads of studs (21) with 'Never-Seez' or equivalent. Install the washers (23) and tighten the nuts (22) finger tight. Do not fully tighten the nuts at this time.

Attach the motor leads to the terminal posts (45) using the nylock machine screws (46). If required, rotate the terminal housing and twist the motor leads to remove excess slack. Secure the terminal housing to the motor housing by torquing the nuts (22) to 11 ft. lbs. (132 inch lbs.). Tighten the nuts (37) drawing the terminal gland (38) down into terminal bore. **Do not** overtighten the nuts and damage the terminal gland or hardware.

See LUBRICATION and FINAL ASSEMBLY.

## LUBRICATION

Check the oil level in the seal cavity and motor housing before initial startup, after the first two weeks of operation, and every month thereafter. If the oil levels are abnormally low, or the color milky or dark, refer to **Draining Oil From Seal And Motor** in this section for instructions and troubleshooting tips.

### NOTE

To accurately check the oil level the pump must be cool.

The grade of lubricant used is critical to the operation of this pump. Use premium quality submersible pump oil of the grade specified in Table 1. Oil must be stored in a clean, tightly closed container in a reasonably dry environment.

Table 1. Typical Pump Oil Properties

Type .....	Premium high viscosity index, anti-wear hydraulic oil
Dielectric .....	26,000(volts-min)
Pour point .....	-20°F to -60°F
Viscosity @ 100°F .....	110 to 155
Viscosity @ 210°F .....	40 to 50
Recommended supplier:	
Gulf Oil Company .....	Gulf Harmony HVI AW 26
Acceptable alternate suppliers:	
Gulf Oil Company .....	Gulf Harmony 32 AW
SOHIO * .....	Energol - HLP 32
Shell Oil Company .....	Tellus 32, Tellus T-23 or T-32
Sun Oil Co. ....	Sunvis 816 or 916
Texaco .....	Rando HD 32 or HD AZ 32
A.R.CO. ....	Duro 32
Exxon .....	Nuto H 32

\* Also Boron & B.P. (British Petroleum) Oil Companies

### Seal Cavity

To fill the seal cavity, remove the seal cavity drain/fill plug (59) in the intermediate, and add the recommended grade of submersible pump oil (approximately 1/2 pint) to the level of the fill plug opening. Maintain the oil at this level. Apply "Loctite Pipe Sealant With Teflon No. 592", or equivalent sealant to the threads of the drain/fill plug, and reinstall and tighten the plug.

### Motor Housing Cavity

Remove the pressure relief valve (50) and add the recommended grade of submersible pump oil (approximately 1 quart) to the motor cavity. **Maintain the oil at this level.** Apply 'Loctite Pipe Sealant With Teflon No. 592', or equivalent sealant, to the threads of the pressure relief valve, and reinstall and tighten the valve.

### FINAL ASSEMBLY

If the discharge flange (10) has been separated from the motor housing, replace the gasket (9) and secure the flange with the nuts (12).

Connect the discharge hose, and position the pump in the sump or wet well. If rigid discharge piping is used, connect the piping after the pump has been positioned. Open any valves in the discharge line.

**For U.S. and International Warranty Information,  
Please Visit [www.grpumps.com/warranty](http://www.grpumps.com/warranty)**

**or call:**

**U.S.: 419-755-1280**

**International: +1-419-755-1352**

**For Canadian Warranty Information,  
Please Visit [www.grcanada.com/warranty](http://www.grcanada.com/warranty)**

**or call:**

**519-631-2870**

**THE GORMAN-RUPP COMPANY • MANSFIELD, OHIO**

**GORMAN-RUPP OF CANADA LIMITED • ST. THOMAS, ONTARIO, CANADA**