

INSTALLATION, OPERATION, AND MAINTENANCE MANUAL

WITH PARTS LIST

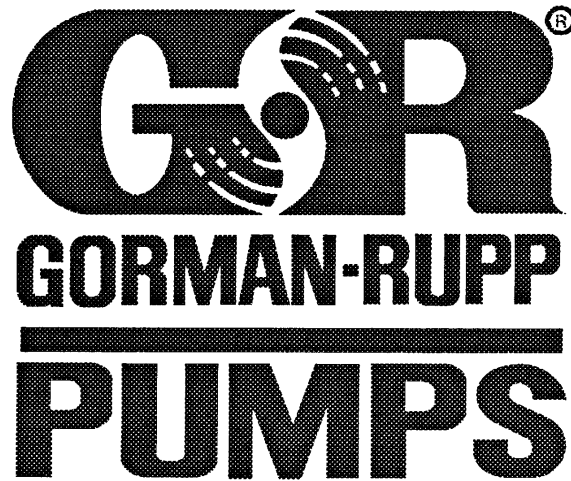

SUBMERSIBLE MINE PUMPS

MODELS
SM4F1-X20 460/3
SM4F1-X20 575/3

THE GORMAN-RUPP COMPANY • MANSFIELD, OHIO

GORMAN-RUPP OF CANADA LIMITED • ST. THOMAS, ONTARIO, CANADA Printed in U.S.A.

©Copyright by the Gorman-Rupp Company

TABLE OF CONTENTS

INTRODUCTION	PAGE I – 1
WARNINGS - SECTION A	PAGE A – 1
INSTALLATION – SECTION B	PAGE B – 1
PREINSTALLATION INSPECTION	PAGE B – 2
Lubrication	PAGE B – 2
PUMP INSTALLATION	PAGE B – 2
Pump Specifications	PAGE B – 2
Pump Dimensions	PAGE B – 3
MSHA Specifications And Approval Data	PAGE B – 4
Lifting	PAGE B – 4
Positioning the Pump	PAGE B – 5
Typical Pump Installations	PAGE B – 5
PIPING	PAGE B – 5
CONTROL BOX INSTALLATION	PAGE B – 6
Enclosure	PAGE B – 6
Control Box Specifications	PAGE B – 6
Control Box Assembly	PAGE B – 7
Parts List – External Parts	PAGE B – 7
Parts List – Mounting Plate Assemblies	PAGE B – 8
Mounting Plate Wiring Schematic	PAGE B – 9
Grounding Methods	PAGE B – 9
Field Wiring Connections (Incoming Power)	PAGE B – 10
Pump Motor Voltage Limits	PAGE B – 10
Pump Power Cable Connections	PAGE B – 11
Pump Power Cable Specifications	PAGE B – 11
Pump Power Cable Connection Diagram	PAGE B – 12
Pump Power Cable Connection Instructions	PAGE B – 12
OPERATION – SECTION C	PAGE C – 1
CONTROL BOX FUNCTION	PAGE C – 1
PUMP OPERATION	PAGE C – 1
Liquid Temperature And Overheating	PAGE C – 2
Checking Pump Rotation	PAGE C – 2
STARTING	PAGE C – 3
STOPPING	PAGE C – 3
Operational Checks	PAGE C – 3
Cold Weather Preservation	PAGE C – 4
TROUBLESHOOTING – SECTION D	PAGE D – 1
ELECTRICAL TESTING	PAGE D – 3
Test Equipment	PAGE D – 3
Voltage Imbalance	PAGE D – 3
Motor And Motor Power Cable Continuity	PAGE D – 4
Insulation Resistance	PAGE D – 4

TABLE OF CONTENTS
(continued)

PUMP MAINTENANCE AND REPAIR - SECTION E	PAGE E - 1
PERFORMANCE CURVE	PAGE E - 1
PARTS LISTS	
Pump Model SM4E1-X20 460/3 & SM4E1-X20 575/3	PAGE E - 3
47367-075 Terminal Housing And Cable Assembly	PAGE E - 5
PUMP AND SEAL DISASSEMBLY AND REASSEMBLY	PAGE E - 6
PUMP END DISASSEMBLY	PAGE E - 7
Strainer Removal	PAGE E - 7
Draining Oil From Seal Cavity	PAGE E - 7
Positioning Pump For Disassembly	PAGE E - 7
Diffuser Removal	PAGE E - 7
Impeller Removal	PAGE E - 7
Lower Seal Removal	PAGE E - 7
Upper Seal Removal	PAGE E - 8
PUMP END REASSEMBLY	PAGE E - 8
Cleaning And Inspection Of Pump Parts	PAGE E - 8
Upper Seal Installation	PAGE E - 9
Lower Seal Installation	PAGE E - 10
Impeller Installation	PAGE E - 11
Strainer Installation	PAGE E - 11
MOTOR DISASSEMBLY	PAGE E - 11
Terminal Housing And Power Cable Removal And Disassembly	PAGE E - 12
Shaft And Rotor Removal	PAGE E - 13
Stator Removal	PAGE E - 14
Hoisting Bail	PAGE E - 14
MOTOR REASSEMBLY	PAGE E - 14
Stator Installation	PAGE E - 15
Shaft And Rotor Installation	PAGE E - 16
Terminal Housing And Power Cable Reassembly And Installation	PAGE E - 17
Sealing Terminal Housing Connections	PAGE E - 17
Terminal Housing Reassembly	PAGE E - 18
FINAL ASSEMBLY	PAGE E - 19
LUBRICATION	PAGE E - 19
Seal Cavity	PAGE E - 19
Pump Oil Specifications	PAGE E - 19
Motor Housing Cavity	PAGE E - 19

INTRODUCTION

This Installation, Operation, and Maintenance manual is designed to help you achieve the best performance and longest life from your Gorman-Rupp pump.

The pump is specifically designed for mine dewatering applications. It is capable of handling most non-volatile, non-flammable liquids encountered in standard mining operations. Refer to the following chart

for the materials of construction for your particular pump. The pump may be operated fully or partially submerged, since the integral air-filled electric motor is thermally protected and cooled by the liquid being pumped. The motor must be operated through the control box furnished with the pump as standard equipment. The pump and control comply with MSHA schedule 2G regulations.

Pump Model	Basic Materials of Construction
SM4F1-X20 460/3 SM4F1-X20 575/3	Aluminum, w/austempered ductile iron impeller, diffuser, and seal plate. Aluminum, w/austempered ductile iron impeller, diffuser, and seal plate.

If there are any questions regarding the pump or its application which are not covered in this manual or in other literature accompanying this unit, please contact your Gorman-Rupp distributor, or write:

The Gorman-Rupp Company
P.O. Box 1217
Mansfield, Ohio 44901-1217

or

Gorman-Rupp of Canada Limited
70 Burwell Road
St. Thomas, Ontario N5P 3R7

The following are used to alert maintenance personnel to procedures which require special attention, to those which could damage equipment, and to those which could be dangerous to personnel:

NOTE

Instructions to aid in installation, operation, and maintenance or which clarify a procedure.

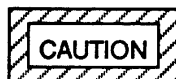

INSTRUCTIONS WHICH MUST BE FOLLOWED TO AVOID CAUSING DAMAGE TO THE PRODUCT OR OTHER EQUIPMENT INCIDENTAL TO THE INSTALLATION. THESE INSTRUCTIONS DESCRIBE THE REQUIREMENTS AND THE POSSIBLE DAMAGE WHICH COULD RESULT FROM FAILURE TO FOLLOW THE PROCEDURES.

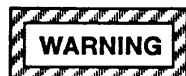

THESE INSTRUCTIONS MUST BE FOLLOWED TO AVOID CAUSING INJURY OR DEATH TO PERSONNEL, AND DESCRIBE THE PROCEDURE REQUIRED AND THE INJURY WHICH COULD RESULT FROM FAILURE TO FOLLOW THE PROCEDURE.

WARNINGS - SECTION A

THESE WARNINGS APPLY TO THE SM-SERIES SUBMERSIBLE MOTOR DRIVEN PUMP AND CONTROL BOX.



BEFORE ATTEMPTING TO OPEN OR SERVICE THE PUMP:

1. FAMILIARIZE YOURSELF WITH THIS MANUAL.
2. LOCK OUT INCOMING POWER TO THE CONTROL BOX TO ENSURE THAT THE PUMP WILL REMAIN INOPERATIVE.
3. ALLOW THE PUMP TO COOL IF OVERHEATED.
4. CLOSE THE DISCHARGE VALVE (IF USED).



THE PUMP IS DESIGNED TO BE OPERATED THROUGH THE CONTROL BOX FURNISHED WITH THE PUMP. THE CONTROL BOX PROVIDES OVERLOAD PROTECTION AND POWER CONTROL. DO NOT CONNECT THE PUMP MOTOR DIRECTLY TO THE INCOMING POWER LINES.

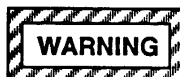

THE ELECTRICAL POWER USED TO OPERATE THIS PUMP IS HIGH ENOUGH TO CAUSE INJURY OR DEATH. OBTAIN THE SERVICES OF A QUALIFIED ELECTRICIAN TO MAKE ALL ELECTRICAL CONNECTIONS. MAKE CERTAIN THAT THE PUMP AND ENCLOSURE ARE PROPERLY

GROUNDING. BE SURE THAT THE INCOMING POWER MATCHES THE VOLTAGE AND PHASE OF THE PUMP AND CONTROL BEFORE CONNECTING THE POWER SOURCE. DO NOT RUN THE PUMP IF THE VOLTAGE IS NOT WITHIN THE LIMITS.



THE ELECTRICAL POWER USED TO OPERATE THIS PUMP IS HIGH ENOUGH TO CAUSE INJURY OR DEATH. MAKE CERTAIN THAT THE CONTROL HANDLE ON THE CONTROL BOX IS IN THE OFF POSITION AND LOCKED OUT, OR THAT THE POWER SUPPLY TO THE CONTROL BOX HAS BEEN OTHERWISE CUT OFF AND LOCKED OUT, BEFORE ATTEMPTING TO OPEN OR SERVICE THE PUMP ASSEMBLY. TAG ELECTRICAL CIRCUITS TO PREVENT ACCIDENTAL START-UP.



ALL ELECTRICAL CONNECTIONS MUST BE IN ACCORDANCE WITH MSHA SCHEDULE 2G. IF THERE IS A CONFLICT BETWEEN THE INSTRUCTIONS PROVIDED AND MSHA SPECIFICATIONS, MSHA SPECIFICATIONS SHALL TAKE PRECEDENCE. ALL ELECTRICAL EQUIPMENT SUPPLIED WITH THIS PUMP WAS IN CONFORMANCE WITH MSHA REQUIREMENTS IN EFFECT ON THE DATE OF MANUFACTURE. FAILURE TO FOLLOW APPLICABLE SPECIFICATIONS, OR SUBSTITUTION OF ELECTRICAL PARTS NOT SUPPLIED OR APPROVED BY THE MANUFACTURER, CAN RESULT IN SEVERE INJURY OR DEATH.

**WARNING**

THIS PUMP IS **NOT** DESIGNED TO PUMP VOLATILE, EXPLOSIVE, OR FLAMMABLE MATERIALS. REFER TO THE CHART IN INSTALLATION, SECTION B FOR THE BASIC MATERIALS OF CONSTRUCTION FOR EACH PUMP COVERED IN THIS MANUAL. **DO NOT** ATTEMPT TO PUMP ANY LIQUIDS FOR WHICH YOUR PUMP IS NOT APPROVED, OR WHICH MAY DAMAGE THE PUMP OR ENDANGER PERSONNEL AS A RESULT OF PUMP FAILURE. CONSULT THE FACTORY FOR SPECIFIC APPLICATION DATA.

**WARNING**

AFTER THE PUMP HAS BEEN INSTALLED, MAKE CERTAIN THAT THE PUMP AND ALL PIPING OR HOSE CONNECTIONS ARE SECURE BEFORE OPERATION.

**WARNING**

APPROACH THE PUMP CAUTIOUSLY AFTER IT HAS BEEN RUNNING. ALTHOUGH THE MOTOR IS COOLED BY THE LIQUID BEING PUMPED, NORMAL OPERATING TEMPERATURES CAN BE HIGH ENOUGH TO CAUSE BURNS. THE TEMPERATURE WILL BE ESPECIALLY HIGH IF OPERATED AGAINST A CLOSED DISCHARGE VALVE. NEVER OPERATE AGAINST A CLOSED DISCHARGE VALVE FOR LONG PERIODS OF TIME.

**WARNING**

DO NOT OPEN THE CONTROL BOX IN AN EXPLOSIVE ATMOSPHERE. WHEN SEALED, THE CONTROL BOX IS EXPLOSION PROOF TO PREVENT THE IGNITION OF COMBUSTIBLE GASES. OPENING THE BOX IN AN EXPLOSIVE ATMOSPHERE COULD RESULT IN FIRE OR EXPLOSION.

INSTALLATION - SECTION B

Review all WARNINGS in Section A.

This section is intended only to summarize recommended installation practices for the pump and control box. If there are any questions concerning your specific application, contact your Gorman-Rupp distributor or the Gorman-Rupp Company

All functions performed by the customer on the pump or control must be done in accordance with MSHA schedule 2G regulations to ensure the explosion-proof integrity. No alterations of original design may be made without the consent of the Gorman-Rupp Company and MSHA.



TO RETAIN "PERMISSIBILITY" OF THIS EQUIPMENT, THE FOLLOWING CONDITIONS SHALL BE SATISFIED:

- 1. GENERAL SAFETY.** FREQUENT INSPECTION SHALL BE MADE. ALL ELECTRICAL PARTS, INCLUDING THE PORTABLE CABLE AND WIRING, SHALL BE KEPT IN A SAFE CONDITION. THERE SHALL BE NO OPENINGS INTO THE CASINGS OF THE ELECTRICAL PARTS. A PERMISSIBLE DISTRIBUTION BOX SHALL BE USED FOR CONNECTION TO THE POWER CIRCUIT UNLESS CONNECTION IS MADE IN FRESH INTAKE AIR. THE MACHINE FRAME SHALL BE EFFECTIVELY GROUNDED. THE POWER WIRES SHALL NOT BE USED FOR GROUNDING. THE OPERATING VOLTAGE MUST MATCH THE VOLTAGE RATING OF THE MOTOR(S) 10%.
- 2. SERVICING.** EXPLOSION-PROOF ENCLOSURES SHALL BE RESTORED TO THE STATE OF ORIGINAL SAFETY WITH RESPECT TO ALL FLAME ARRESTING PATHS, LEAD ENTRANCES, ETC., FOLLOWING DISASSEMBLY FOR REPAIR OR REBUILDING, WHETHER BY THE OWNER OR AN INDEPENDENT SHOP.
- 3. FASTENING.** ALL BOLTS, NUTS, SCREWS, AND OTHER MEANS OF FASTENING, AND ALSO THREADED COVERS, SHALL BE IN PLACE, PROPERLY TIGHTENED AND SECURED.
- 4. RENEWALS AND REPAIRS.** INSPECTIONS, REPAIRS, OR RENEWALS OF ELECTRICAL PARTS SHALL NOT BE MADE UNLESS THE PORTABLE CABLE IS DISCONNECTED FROM THE CIRCUIT FURNISHING POWER, AND THE CABLE SHALL NOT BE CONNECTED AGAIN UNTIL ALL PARTS ARE PROPERLY REASSEMBLED. SPECIAL CARE SHALL BE TAKEN IN MAKING RENEWALS OR REPAIRS. LEAVE NO PARTS OFF. USE REPLACEMENT PARTS EXACTLY LIKE THOSE FURNISHED BY THE MANUFACTURER. WHEN ANY LEAD ENTRANCE IS DISTURBED, THE ORIGINAL LEADS OR EXACT DUPLICATES THEREOF SHALL BE USED AND STUFFING BOXES SHALL BE REPACKED IN THE APPROVED MANNER.
- 5. CABLE REQUIREMENTS.** A FLAME-RESISTANT PORTABLE CABLE BEARING A MSHA-ASSIGNED IDENTIFICATION NUMBER, ADEQUATELY PROTECTED BY AN AUTOMATIC CIRCUIT-INTERRUPTING DEVICE, SHALL BE USED. SPECIAL CARE SHALL BE TAKEN IN HANDLING THE CABLE TO GUARD AGAINST MECHANICAL INJURY AND WEAR. SPLICES IN PORTABLE CABLES SHALL BE MADE IN A WORKMANLIKE MANNER, MECHANICALLY STRONG, AND WELL INSULATED. ONE TEMPORARY SPLICE MAY BE MADE IN ANY TRAILING CABLE. SUCH TRAILING CABLE MAY ONLY BE USED FOR THE NEXT 24-HOUR PERIOD. NO TEMPORARY SPLICE SHALL BE MADE IN A TRAILING CABLE WITHIN 25 FEET OF THE MACHINE, EXCEPT CABLE REEL EQUIPMENT. CONNECTIONS AND WIRING TO THE OUTBY END OF THE CABLE SHALL BE IN ACCORDANCE WITH RECOGNIZED STANDARDS OF SAFETY.

This section is intended only to summarize recommended installation practices for the pump and control box. If there are any questions concerning your specific installation, contact your Gorman-Rupp distributor or the Gorman-Rupp Company.

PREINSTALLATION INSPECTION

The pump and control box were inspected and tested before shipment from the factory. Before installation, inspect the pump for damage which may have occurred during shipment. Check as follows:

- a. Inspect the pump assembly for cracks, dents, damaged threads, and other obvious damage.
- b. Check for and tighten loose attaching hardware. Since gaskets tend to shrink after drying, check for loose hardware at mating surfaces.
- c. The standard pump is furnished with 50 feet of power cable. Inspect the cable for cuts or damage.
- d. Inspect the control box for cracks, dents, and other obvious damage.
- e. Check that all control box components are securely attached to their mounting surfaces, and that the electrical connections are tight and free of corrosion.
- f. Compare the amperes, phase, voltage and hertz indicated on the motor nameplate to the ratings indicated for the control box.
- g. Carefully read all tags, decals, and markings on the pump assembly and the control box, and perform all duties as indicated.
- h. Check the pump and motor for any oil leaks. An oil leak may indicate a cut O-ring or other damage.
- i. If the pump and control box have been stored for more than 12 months, some of the components or lubricants may have exceeded their maximum shelf life. These **must be inspected or replaced** to ensure maximum pump service.

If the maximum shelf life has been exceeded, or if anything appears to be abnormal, contact your Gorman-Rupp distributor or the factory to determine the repair or updating policy. **Do not** put the pump into service until appropriate action has been taken.

Lubrication

This pump utilizes one lubrication cavity, located just behind the seal plate. It is filled with premium quality submersible pump oil which lubricates two shaft seals. The motor operates in air and requires no lubrication.

The lower shaft seal prevents liquid from entering the lubrication cavity, while the upper shaft seal prevents oil leakage into the motor. The upper seal also acts as backup protection in the event of lower seal failure.

The lubrication cavity was fully lubricated when shipped from the factory. Check the oil level before installing the pump (see **LUBRICATION** in **MAINTENANCE AND REPAIR**). An additional quart of oil has been provided with the pump to "top off" the oil cavity. If the oil level is abnormally low, determine the cause before putting the pump into service.

PUMP INSTALLATION

Pump Specifications

See Tables 1 and 2 for pump specifications and motor data.

Table 1. Pump Specifications

Model	Voltage/Phase	Motor Horsepower	Motor Speed (RPM)	Full Load Amperes	No Load Amperes	Locked Rotor Amperes	Discharge Size (NPT)
SM4F	460/3	20	3450	26	4.4	170	4 INCH
SM4F	575/3	20	3450	20.8	3.5	136	4 INCH

Table 2. Additional Specifications

Approximate Weights:	
Pump:	
Models SM4F1-X20 460/3 & 575/3	188 lbs. (85.3 kg)
Control Box Only	32 lbs. (14 kg)
50 ft. of Cable	23 lbs. (10.4 kg)
Seal oil cavity capacity	1 U.S. quart (0.9 liter)

Pump Dimensions

The standard pump is provided with a suction strainer to prevent large solids from clogging the impeller. On high discharge head applications, the

strainer can be removed, and the pump suction “staged” to the discharge of another pump, allowing one pump to feed the other. See Figure 1 for the approximate physical dimensions of this pump and control box.

OUTLINE DRAWING

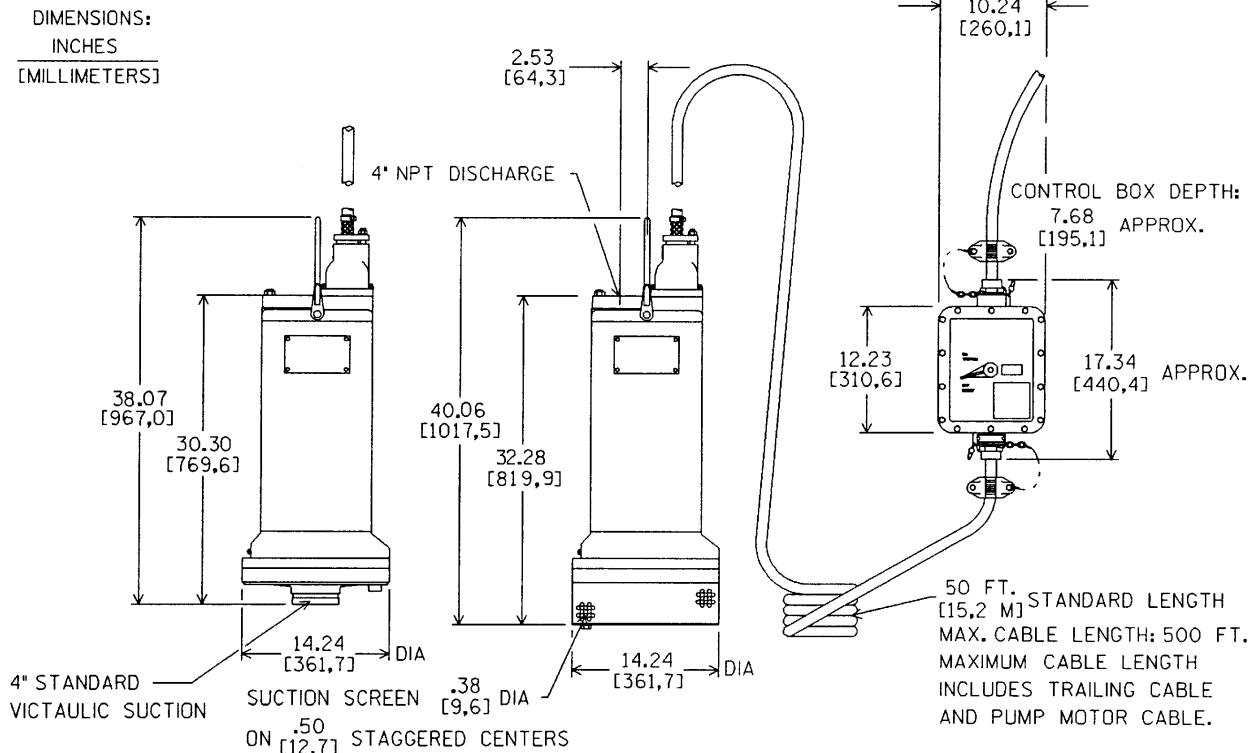

Figure 1. SM4F1-X20 460/3 And SM4F1-X20 575/3 Pump Models

Table 3. MSHA Specifications And Approval Data

MSHA Approval Number (All Models) 2G-3971A-0				
Motor	MSHA No.	G-R P/N	Size	G-R Dwg. No.
Model SM4F1-X20 460/3 Model SM4F1-X20 575/3	XP-3691-0 XP-3691-0	15951 15951	D D	15951 Shts. 1 thru 3
Control Box (Starter)				
460V Models 575V Models	XP-3026-1 XP-3026-1	47631-152 47631-153	D D	47631-064 47631-064
Motor Cable				
#8 AWG., 9 Conductor, 600/2000V, Type SPC, Yellow Jacket 1.05 ± 0.03 O.D., Royal - MSHA P-122-59, Max Length: 460V - 250 Ft., 575V - 500 Ft.	P-122-MSHA	47325-010	B	47325-010
Trailing Cable	Customer Furnished			
#6 Ga., 3 Conductor Type G-GC, 1.05 ± 0.03 O.D. 600/2000V, 90°C, Protected by an Instantaneous Trip Circuit Breaker set at 300 Amps Max., Flame Resistant, Max. Length 500 Ft.				
Strain Clamps (4 Items, 2 Req'd)		38116-603	B	38116-603
Cable Protector (4 Req'd)		33573-001	B	33573-001
Approval Plate		2613ES	B	2613ES
Wiring Diagram			C	15374D
Caution Statement				Form No. 060282-1
Factory Inspection Form				Form No. GL-02128
Cable Grip	Alum. Collar-302/304 SST Grip	11227-L	B	11227-L
	All SST 316	41332-514		

Lifting

Use lifting equipment with a capacity of at least **5 times the weight of the complete unit** (include the weight of any customer-installed accessories, the power cable, and the control box if all are to be lifted). Refer to Table 1A for weights. Customer-installed equipment such as discharge piping **must** be removed before attempting to lift.



DO NOT ATTEMPT TO LIFT THE PUMP BY THE MOTOR POWER CABLE OR THE PIPING. ATTACH PROPER LIFTING EQUIPMENT TO THE LIFTING DEVICE FITTED TO THE PUMP. IF CHAINS OR CABLE ARE WRAPPED AROUND THE PUMP TO LIFT IT, MAKE CERTAIN THAT THEY ARE POSITIONED SO AS NOT TO DAMAGE PUMP, AND SO THAT THE LOAD WILL BE BALANCED.

Positioning the Pump

This pump is designed to operate fully or partially submerged. It may also be operated in air for extended periods. The rotating parts are oil lubricated, and the motor is cooled by a constant flow of air discharged through internal passages.

The pump will operate if positioned on its side, but this is not recommended because the motor torque could cause the pump to roll during operation.

The pump should be independently secured and supported by the lifting device fitted on the pump. If the application involves a lot of debris, protect the pump from excessive wear and clogging by suspending it in a perforated barrel or culvert pipe. If the bottom is heavily sludge-covered, rest the pump on support blocks or suspend it from a raft or similar device near the surface of the liquid. See Figure 2 for typical pump installations.

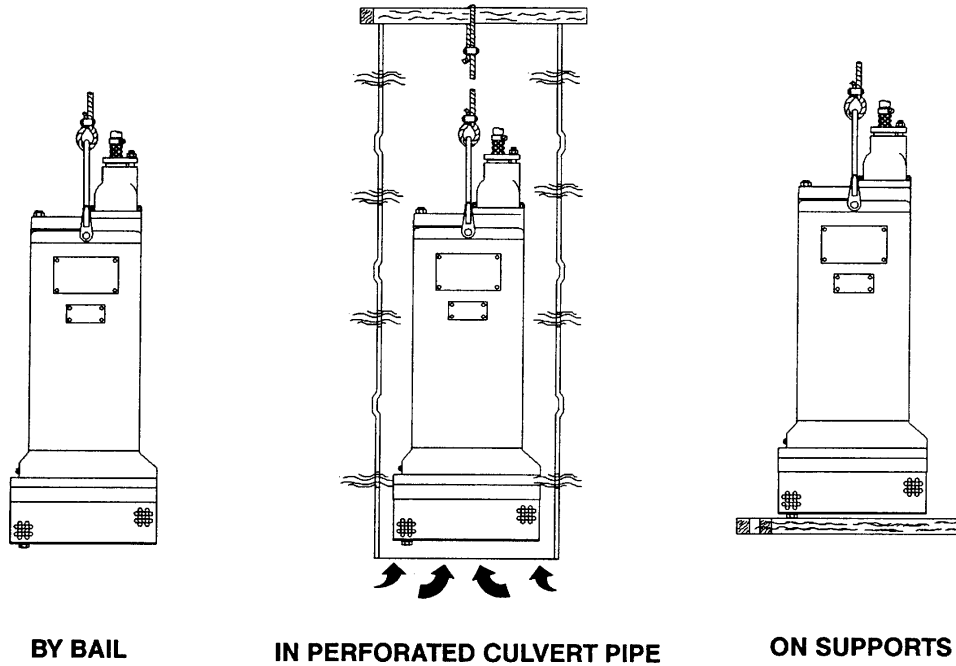

Figure 2. Typical Pump Installations

All liquid entering the pump must pass through a strainer screen. Any spherical solids which pass through the screen will pass through the pump.

NOTE

*Before actual operation, check the direction of impeller rotation to ensure that the pump is properly wired to the control box. See **Checking Pump Rotation** in **OPERATION**, Section C.*

The pump is provided with a suction strainer to prevent large solids from clogging the impeller. On high discharge head applications, the strainer can be removed, and the pump suction "staged" to the discharge of another pump, allowing one pump to feed the other.

To determine the size of the discharge connection, see Table 1, **Pump Specifications**. Either hose or rigid pipe may be used. To facilitate mobility and maintenance, it is recommended that the discharge line be fitted with a quick disconnect fitting near the pump. The discharge line must be independently supported to avoid strain and vibration on the pump.

PIPING

No suction piping is required in a standard submerged application.

For maximum pumping capacity, keep the discharge as short and straight as possible. Minimize the use of elbows and fittings which increase friction losses through the discharge piping system.

It is recommended that a check valve or throttling valve be installed in the discharge line to control siphoning or back flow when the pump is shut off.

CONTROL BOX INSTALLATION

This pump is driven by an integral 20 horsepower motor. It is designed to operate through the control box furnished with the pump.



THE PUMP IS DESIGNED TO BE OPERATED THROUGH THE CONTROL BOX FURNISHED WITH THE PUMP. THE CONTROL BOX PROVIDES OVERLOAD PROTECTION AND POWER CONTROL. DO NOT CONNECT THE PUMP MOTOR DIRECTLY TO THE INCOMING POWER LINES.

Enclosure

The control box is a NEMA type 10, MSHA certified enclosure. **The enclosure is not designed to be watertight, and should not be submerged.** See Figure 3 on page B - 7 for enclosure dimensions and callouts.

Secure the control box vertically on a level surface, above flood level. The box should be easily accessible to the operator, and located close enough to the pump to avoid excessive voltage drop due to cable length (see **Pump Power Cable Connections**). After the box is installed, make certain the front cover latches properly.

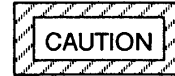

FAILURE TO MOUNT THE CONTROL BOX VERTICALLY ON A LEVEL SURFACE MAY AFFECT OPERATION OF THE PUMP CONTROLS.

Table 4. Control Box Specifications

Model	Voltage/Phase	Control Box Part No.	Mtg. Plate Part No.	Relay Rating (Amps)	Hold Amps	Trip Amps	MSHA Cert. No.
SM4F	460/3	47631-152	47882-007	27	27.0	33.8	XP-3026-1
SM4F	575/3	47631-153	47882-008	22	22.0	27.5	XP-3026-1

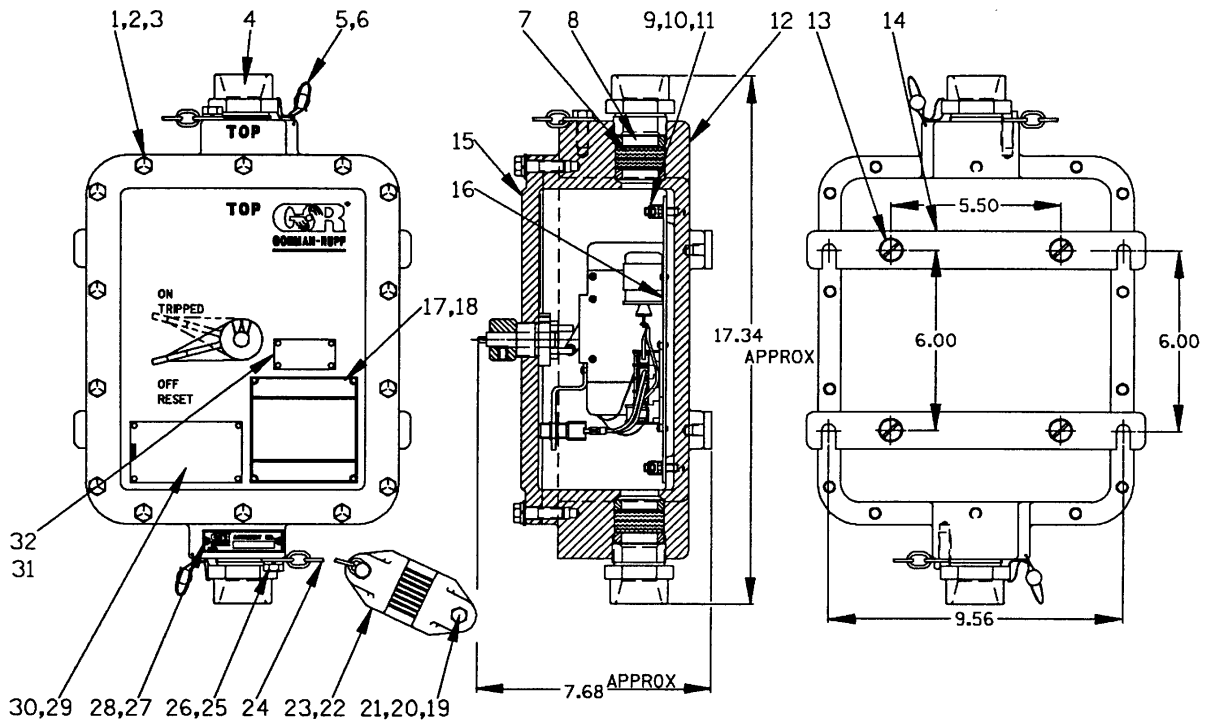

Figure 3. Control Box Assembly

PARTS LIST - EXTERNAL PARTS
47631-152 (460V) AND 47631-153 (575V) CONTROL BOXES
 (See Figure 4 For Internal Control Box Parts)

ITEM NO.	PART NAME	PART NUMBER	MAT'L CODE	QTY	ITEM NO.	PART NAME	PART NUMBER	MAT'L CODE	QTY
1	HEX HD CAPSCREW	21632-597	----	14	*	-SHAFT BUSHING	31513-031	13155	1
2	LOCKWASHER	J06	15991	14	*	-BUSHING SETSCREW	GA#10-01S	15990	1
3	FLAT WASHER	KE06	15991	14		-WIRING DECAL	2613GM	----	1
4	PACKING GLAND NUT	31874-017	13045	2	16	MTG PLT ASSY (460V)	47882-007	----	1
5 *	LEAD SEAL	21188-002	----	2		MTG PLT ASSY (575V)	47882-008	----	1
6 *	WIRE - 14 INCH	31311-004	17990	2	17	MSHA CERT PLATE	2613GL	17020	1
7 *	ROPE PACKING	31313-010	22120	1	18	DRIVE SCREW	BM#04-03	17000	4
8 *	PACKING WASHER	31133-129	13150	4	19	HEX HD CAPSCREW	B0609	15991	4
9	GROUND LUG	27222-004	----	2	20	LOCKWASHER	J06	15991	4
10	HEX HD CAPSCREW	B0402	15991	4	21	HEX NUT	D06	15991	4
11	LOCKWASHER	J04	15991	4	22	CABLE CLAMP	38116-603	13040	4
12	ENCLOSURE	38383-001	13045	1	23	RUB BRKT PROTECTOR	33573-001	19990	4
13	FL HD MACH SCREW	Y0602	15991	4	24	CHAIN - 3/16 X 12	41158-009	15991	2
14	MOUNTING BRACKET	33657-002	13090	2	25	HEX HD CAPSCREW	B0604	15991	2
15 *	ENCL COVER ASSY	42114-074	----	1	26	LOCKWASHER	J06	15991	2
	-ENCLOSURE COVER	38383-401	13015	1	27	ASSEMBLY PLATE	2613GG	17020	1
	* -ON/OFF HANDLE	38421-012	13040	1	28	DRIVE SCREW	BM#04-03	17000	2
	* -HANDLE SETSCREW	GA0501 1/2	15990	1	29	MSHA APPROVAL PLATE	2613ES	17020	1
	* -SHAFT ASSY	41881-276	24150	1	30	DRIVE SCREW	BM#04-03	17000	2
					31	NOT REQUIRED			
					32	NOT REQUIRED			

* INDICATES PARTS RECOMMENDED FOR STOCK

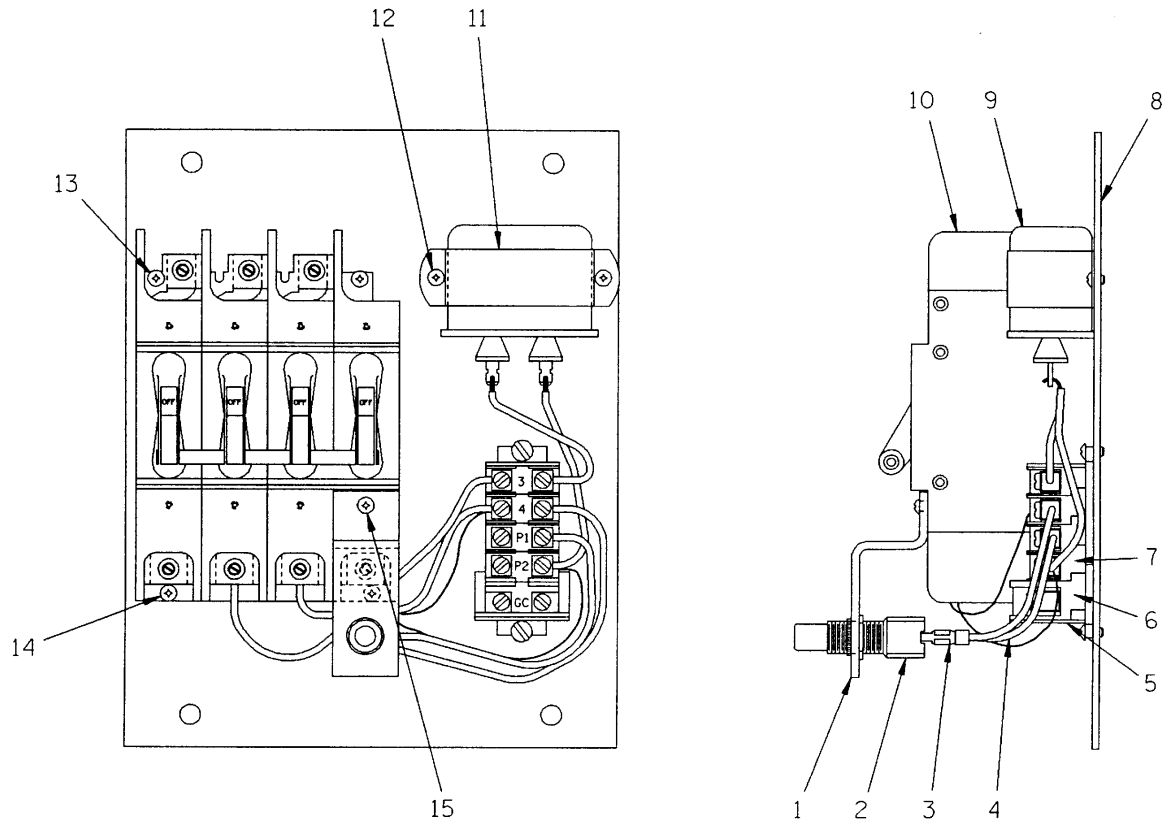

Figure 4. Electrical Mounting Plate Assembly

PARTS LIST

47882-007 (460V) AND 47882-008 (575V) MOUNTING PLATE ASSEMBLIES

(See Figure 3 For External Control Box Parts)

ITEM NO.	PART NAME	PART NUMBER	MAT'L CODE	QTY
1	SWITCH BRACKET	34512-027	15020	1
2	* CUTLER HAMMER SWITCH	27341-211	-----	1
3	TERMINAL	S1790	-----	2
4	WIRE - 14 GA. X 36.5 IN. LG.	38746-027	-----	1
5	TERMINAL BLOCK END	27233-026	-----	1
6	TERMINAL BLOCK	27233-216	-----	1
7	TERMINAL BLOCK	27233-203	-----	4
8	MOUNTING PLATE	33287-011	13090	1
9	* G-E CAPACITOR	27571-332	-----	1
10	* RELAY/SHUNT TRIP (460V)	27541-323	-----	1
	* RELAY/SHUNT TRIP (575V)	27541-331	-----	1
11	CAPACITOR BRACKET	27581-904	-----	1
12	RD PHILLIP MACH SCREW W/WASHER	21771-551	-----	2
13	RD PHILLIP MACH SCREW W/WASHER	21771-552	-----	4
14	RD PHILLIP MACH SCREW W/WASHER	21771-553	-----	2
15	RD PHILLIP MACH SCREW W/WASHER	21771-542	-----	1

* INDICATES PARTS RECOMMENDED FOR STOCK

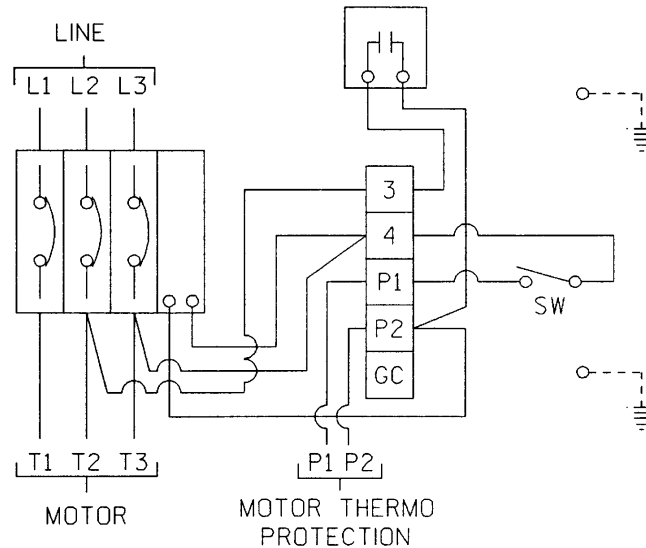

Figure 5. Mounting Plate Wiring Schematic

Grounding Methods

Electrically ground the installation before before connecting the field wiring to the control box. Install a grounding terminal to the enclosure and connect it to a properly embedded electrode.

The material used for the electrode **must** be an excellent conductor of electricity, such as copper. If

iron or steel is used, it must be galvanized or otherwise metal plated to resist corrosion. **Do not** coat the electrode with any material of poor conductivity, such as paint or plastic.

The electrode must conform to the recommendations of MSHA. Follow all installation requirements of MSHA, and all applicable codes. See Figure 6 for some suggested grounding methods.

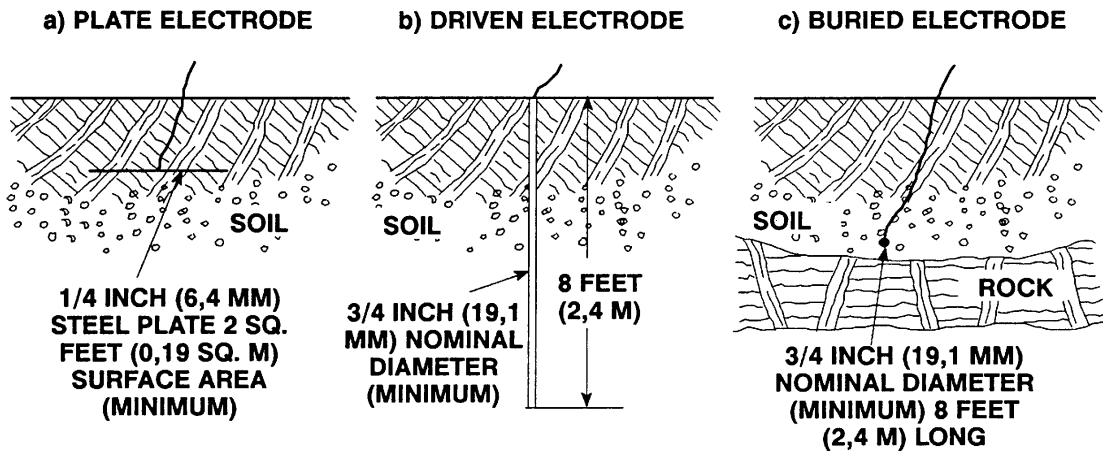

Figure 6. Suggested Grounding Methods

a. **Plate Electrode:** An iron or steel plate, 1/4 inch (6,4 mm) thick, completely impeded in the ground. The plate must present a surface area of at least 2 square feet (1858,1 sq. cm).

b. **Driven Electrode:** A rod or pipe, 3/4 inch (19,1 mm) in diameter minimum, 8 feet (2,4 m) long, completely driven into the ground.

c. **Buried electrode:** If rock or stone prevents embedding the full 8 foot (2,4 m) length of the ground rod, bury it horizontally in a trench.

Space the ground rod or plates at least 6 feet (1,8 m) from any other electrode or ground rod, such as those used for signal circuits, radio grounds, lightning rods, etc.

The earth surrounding the ground rod or plate **must** contain enough moisture to make a good electrical connection. In dry or sandy areas, pour water around the rod, or consult qualified personnel to devise a method of improving the connection.



THE ELECTRICAL POWER USED TO OPERATE THIS PUMP IS HIGH ENOUGH TO CAUSE INJURY OR DEATH. MAKE CERTAIN THAT THE CONTROL BOX IS PROPERLY GROUNDED AFTER INSTALLATION.

Field Wiring Connections (Incoming Power)

The trailing cable from the power source to the control box must be furnished by the customer. The cable must be flame-resistant, protected by an instantaneous circuit breaker, and meet the specifications indicated in Table 3 in this section.



THE ELECTRICAL POWER USED TO OPERATE THIS PUMP IS HIGH ENOUGH TO CAUSE INJURY OR DEATH. OBTAIN THE SERVICES OF A QUALIFIED ELECTRICIAN TO MAKE ALL ELECTRICAL CONNECTIONS. MAKE CERTAIN THAT THE PUMP AND ENCLOSURE ARE PROPERLY GROUNDED; NEVER USE GAS PIPE AS AN ELECTRICAL GROUND. BE SURE THAT THE INCOMING POWER MATCHES THE VOLTAGE AND PHASE OF THE PUMP AND CONTROL BEFORE CONNECTING THE POWER SOURCE. DO NOT RUN THE PUMP IF THE VOLTAGE IS NOT WITHIN THE LIMITS.



DO NOT OPEN THE CONTROL BOX IN AN EXPLOSIVE ATMOSPHERE. WHEN SEALED, THE CONTROL BOX IS EXPLOSION PROOF TO PREVENT THE IGNITION OF COMBUSTIBLE GASES. OPENING THE BOX IN AN EXPLOSIVE ATMOS-

HERE COULD RESULT IN FIRE OR EXPLOSION.

The pump control is designed to regulate a 460 or 575 volt, 3 phase, 60 hertz power supply (see Table 4 for control box specifications). The field wiring must be properly sized to ensure an adequate voltage supply. The voltage available **at the motor** must be within the range indicated in Table 5.

To calculate the voltage available at the motor, proceed as follows:

- a. Measure the incoming voltage across lines 1 & 2, 2 & 3, and 1 & 3 **while the pump is operating at full capacity**. See the wiring diagrams in this section for power supply connections.
- b. Next, subtract the motor cable voltage drop (see Table 6, **Pump Power Cable Specifications**).
- c. Do not continue to operate the pump if this voltage is not within the recommended limits. Obtain the services of a qualified electrician to determine the correct field wiring size and other details to insure an adequate voltage supply to the pump.

Table 5. Pump Motor Voltage Limits

Nominal Voltage	Phase	Minimum Voltage	Maximum Voltage
460	3	420	500
575	3	520	630

Use the packing gland nuts to secure and seal the incoming field wiring to the control box. make certain all connections are tight and that cable entry points are rainproof. Support the cable weight, if required, to prevent excessive strain on cable clamps and cable.

NOTE

*After the power cables have been connected to the control box, the packing gland nuts must be wired and sealed before operation. See **Terminal Housing And Power Cable Reassembly** in Section E for instructions.*

Pump Power Cable Connections



THE ELECTRICAL POWER USED TO OPERATE THIS PUMP IS HIGH ENOUGH TO CAUSE INJURY OR DEATH. OBTAIN THE SERVICES OF A QUALIFIED ELECTRICIAN TO MAKE ALL ELECTRICAL CONNECTIONS. **MAKE CERTAIN THAT INCOMING POWER TO THE CONTROL BOX IS IN THE OFF POSITION AND LOCKED OUT, OR THAT THE POWER SUPPLY TO THE CONTROL BOX HAS BEEN OTHERWISE CUT OFF AND LOCKED OUT, BEFORE CONNECTING POWER OR ACCESSORY CABLES.**

The standard pump is provided with a 50 foot power cable (see table 6 for cable specifications). If a longer cable is required, an optional cable assembly **must** be ordered from the factory. Splicing of the power cable is **not** recommended by the Gorman-Rupp Company due to safety and warranty considerations.



NEVER ATTEMPT TO ALTER THE LENGTH OR REPAIR ANY POWER CABLE WITH A SPLICE. THE PUMP MOTOR AND CABLE MUST BE COMPLETELY WATERPROOF. INJURY OR DEATH MAY RESULT FROM ALTERATIONS.

Table 6. Pump Power Cable Specifications Model SM4E

Voltage/ Phase	A.W.G Cable Size	Cable O.D. (Inches)	Conductor Dia. (Inches)	Amp Rating * at 40°C (Amperes)	DC Resistance at 25°C (ohms/1000 ft.)	Voltage Drop at Max. Load per 100 ft.
460/3	8	1.05	0.17	59	0.71	3.69
575/3	8	1.05	0.17	59	0.71	2.95

* Applies only to type SPC cable. Refer to manufacturer's specifications for other cable.

When necessary to change or connect the pump power cable to the control box, make certain the incoming power is **OFF** and **LOCKED OUT**. Make certain the control box is **PROPERLY GROUNDED** and that the electrical data on the control matches the motor name plate data.

Connect the pump power cable to the control box as shown in Figure 7 in this section. Use conduit or cable clamps to secure the power and accessory cables to the control box. Make certain that all connections are tight and that cable entry points are rainproof.

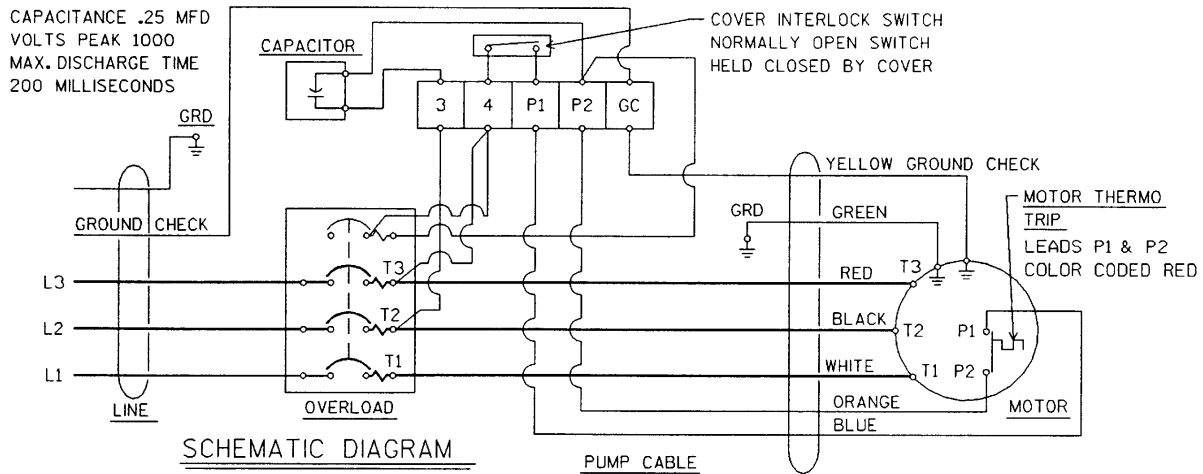

Figure 7. Pump Power Cable Connection Diagram (All Models)

PUMP POWER CABLE CONNECTION INSTRUCTIONS

1. Run the pump cable through the packing gland nuts and washers (the concave side of the washer should be toward the packing) at the bottom of the control.
2. Connect the white, black and red power leads to terminals "T1", "T2", and "T3", respectively.
3. Connect the green ground lead to terminal "GRD".
4. Connect the yellow ground check lead to terminal "GC".
5. Connect the blue control lead to terminal "P1".
6. Connect the orange control lead to terminal "P2".
7. Trim back the two brown control leads to the exit of the casing jacket at both ends. These leads are not required.
8. Install the packing in the gland with the washers on each side, and tighten the packing gland nut. With the nuts tight and the packing fully compressed, there must be a minimum space of 1/8 inch between the bottom of the nut and the enclosure.
9. Use the seal wire (P/N 31311-004) and lead seal (P/N 21188-002) to secure the packing gland nut to the enclosure. Use the hole in the hex nut and the hole at the top left of the enclosure to prevent loosening of the nut. See **Terminal Housing And Power Cable Reassembly And Installation** in Section E for details.

OPERATION – SECTION C

Review all warnings in Section A.

Follow the instructions on all tags, labels and decals attached to the pump and control box.

CONTROL BOX FUNCTION

A control box is provided to facilitate operation of the pump. It contains controls for starting and stopping the pump, and provides overload protection for the pump motor.



THE PUMP IS DESIGNED TO BE OPERATED THROUGH THE CONTROL BOX FURNISHED WITH THE PUMP. THE CONTROL BOX PROVIDES OVERLOAD PROTECTION AND POWER CONTROL. DO NOT CONNECT THE PUMP MOTOR DIRECTLY TO THE INCOMING POWER LINES.

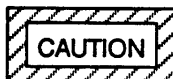

SINCE OPERATION OF THE PUMP MOTOR IS DEPENDENT UPON THE QUALITY AND PERFORMANCE OF THE ELECTRICAL CONTROLS, THE PUMP WARRANTY IS VALID ONLY WHEN CONTROLS HAVE BEEN SPECIFIED OR PROVIDED BY THE GORMAN-RUPP COMPANY.

Component Function

The control box contains the following hand-operated switches and controls:

- **The control handle** operates the control box circuit breakers. In the OFF position, the control handle opens the circuit breakers to interrupt incoming power through the control box and prevent pump operation. In the ON posi-

tion, it closes the circuit breakers to permit pump operation. The circuit breakers will open or “trip” automatically in the event of a short circuit overload current, or thermal excess within the pump motor or electrical system. When tripped, move the control handle to OFF and back to ON to reset the circuit breakers.

- The control box contains an integral safety switch which automatically “trips” the circuit breakers when the cover is removed. **Never** remove the cover in an explosive atmosphere. Make certain incoming power is OFF and LOCKED OUT.
- The motor is thermally protected by a thermostat within the stator. In the event of motor overheating, the thermostat will open and automatically “trip” the control box circuit breakers. The motor will not restart until the circuit breakers are reset.

NOTE

If the circuit breaker trips, do not reset it immediately. Wait at least ten minutes before resetting the control handle back to the ON position. If the overload unit continues to trip, operational problems exist. See TROUBLESHOOTING.

PUMP OPERATION

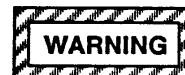

THIS PUMP IS DESIGNED TO HANDLE MOST NON-VOLATILE, NON-FLAMMABLE LIQUIDS ENCOUNTERED IN MINE DEWATERING. DO NOT ATTEMPT TO PUMP VOLATILE, EXPLOSIVE, OR FLAMMABLE MATERIALS, OR ANY LIQUIDS WHICH MAY DAMAGE THE PUMP OR ENDANGER PERSONNEL AS A RESULT OF PUMP FAILURE.

Liquid Temperature And Overheating

The maximum liquid temperature for this pump is 120° F (102.2° C). Do not apply the pump at higher operating temperatures.



APPROACH THE PUMP CAUTIOUSLY AFTER IT HAS BEEN RUNNING. ALTHOUGH THE MOTOR IS COOLED BY THE LIQUID BEING PUMPED, NORMAL OPERATING TEMPERATURES CAN BE HIGH ENOUGH TO CAUSE BURNS. THE TEMPERATURE WILL BE ESPECIALLY HIGH IF OPERATED AGAINST A CLOSED DISCHARGE VALVE. NEVER OPERATE AGAINST A CLOSED DISCHARGE VALVE FOR LONG PERIODS OF TIME.

If overheating does occur, stop the pump immediately and allow it to cool before servicing it. Approach any overheated pump cautiously.



OVERHEATED PUMPS CAN CAUSE SEVERE BURNS AND INJURIES. IF OVERHEATING OF THE PUMP OCCURS:

1. STOP THE PUMP IMMEDIATELY.
2. VENTILATE THE AREA.
3. ALLOW THE PUMP TO COOL.
4. CHECK THE TEMPERATURE BEFORE SERVICING.
5. VENT THE PUMP SLOWLY AND CAUTIOUSLY.
6. REFER TO INSTRUCTIONS IN THIS MANUAL BEFORE RESTARTING THE PUMP.

Checking Pump Rotation



DO NOT OPEN THE CONTROL BOX IN AN EXPLOSIVE ATMOSPHERE. WHEN SEALED, THE CONTROL BOX IS EXPLOSION PROOF TO PREVENT THE IGNITION OF COMBUSTIBLE GASES. OPENING THE BOX IN AN EXPLOSIVE ATMOSPHERE COULD RESULT IN FIRE OR EXPLOSION.

Check the direction of pump rotation before operation to ensure that the impeller is rotating in the correct direction.

Suspend the pump from the lifting device fitted on the pump. Turn the pump on momentarily and note the direction of twist. For correct rotation and operation, the twist must be in a **counterclockwise** direction when viewed from the **top** (see Figure 1).

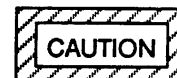

SECURE THE PUMP DURING ROTATION TO PREVENT COILING OF THE POWER CABLE.

If the pump twists clockwise on start, interchange any two motor leads at the control box.

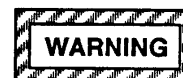

THE ELECTRICAL POWER USED TO OPERATE THIS PUMP IS HIGH ENOUGH TO CAUSE INJURY OR DEATH. MAKE CERTAIN THAT INCOMING POWER IS OFF AND LOCKED OUT BEFORE INTERCHANGING MOTOR LEADS.

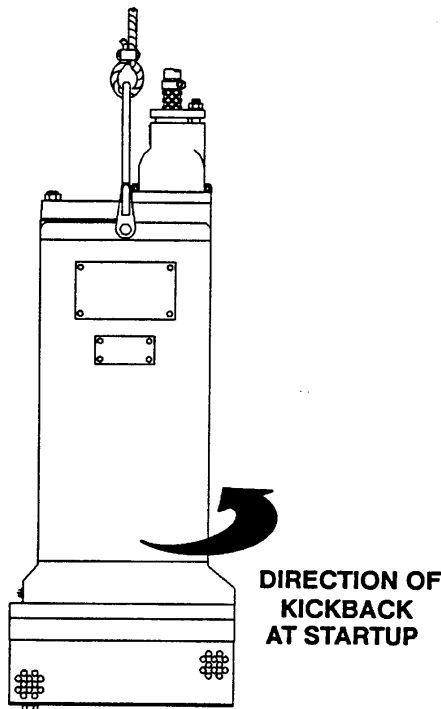

Figure 1. Checking Pump Rotation

STARTING

After the pump and control box have been installed, start the pump as follows.

NOTE

*Before actual operation, check the direction of impeller rotation to ensure that the pump is properly wired. See **Checking Pump Rotation** in this section.*

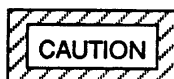

NEVER START THE PUMP MORE THAN 6 TIMES PER HOUR. IF THE PUMP MOTOR DOES NOT COOL BETWEEN STARTS, IT WILL OVER-HEAT, RESULTING IN DAMAGE TO THE MOTOR WINDINGS OR CONTROL BOX COMPONENTS.

Move the control handle to the ON position. The pump motor will start running, and pumping should begin. Since the pump is submerged, priming is not required.

STOPPING

To stop the pump, turn the control handle OFF, thereby opening the circuit breaker.

This **does not** terminate incoming power through the field wiring connected to the control box.

After stopping the pump, be sure to perform all required maintenance and preservation procedures.

NOTE

It is recommended that a check valve or throttling valve be installed in the discharge line if there is any possibility of siphoning or back flow when the pump is shut off.

Operational Checks

Check the pump for proper operation when it is first started and periodically thereafter to identify minor problems.

Check the pump for unusual noises or excessive vibration while it is operating. If noise or vibration is excessive, stop the pump and refer to the troubleshooting chart for possible causes.

Check the pump strainer screen for clogging caused by stones, sticks, or other debris. Clean the strainer screen when required. In some cases, stopping the pump momentarily may back flush the strainer screen, purging most of the debris from it. If this fails to clean the screen, remove the pump from the sump and remove the debris manually (see **PUMP END DISASSEMBLY** in Section E).

Never introduce air or steam pressure into the pump casing or piping to remove a blockage. This could result in personal injury or damage to the equipment. If backflushing is absolutely necessary, **liquid pressure** must be limited to 50% of the maximum permissible operating pressure shown on the pump performance curve (see **MAINTENANCE AND REPAIR**, Section E).

Check the pump for overheating. The pump could overheat if operated against a closed discharge valve, or if subjected to repeated start cycles.

Cold Weather Preservation

In freezing temperatures, the pump will not freeze as long as it is submerged in liquid. If the pump casing is not submerged, or if the liquid begins to freeze, remove the pump from the sump or wet well and allow it to dry thoroughly. Run the pump for two or three minutes to dry the inner walls.

If the pump freezes, move it into a warm area until completely thawed, or submerge it into the liquid. If

the liquid is near freezing, the pump must be submerged for an extended period of time. Start the pump and check for shaft rotation. If still frozen, allow additional thawing time before attempting to restart.



DO NOT ATTEMPT TO THAW THE PUMP BY USING A TORCH OR OTHER SOURCE OF FLAME. THIS COULD DAMAGE GASKETS OR HEAT THE OIL WITHIN THE PUMP ABOVE THE CRITICAL POINT AND CAUSE THE PUMP TO RUPTURE OR EXPLODE.

TROUBLESHOOTING - SECTION D

Review all WARNINGS in Section A.



THE ELECTRICAL POWER USED TO OPERATE THIS PUMP IS HIGH ENOUGH TO CAUSE INJURY OR DEATH. OBTAIN THE SERVICES OF A QUALIFIED ELECTRICIAN TO TROUBLESHOOT, TEST AND/OR SERVICE THE ELECTRICAL COMPONENTS OF THIS PUMP.

TROUBLE	POSSIBLE CAUSE	PROBABLE REMEDY
<p>PUMP FAILS TO START, CIRCUIT BREAKER NOT TRIPPED</p>	<p>Power source incompatible with control box.</p> <p>No voltage at line side of circuit breaker.</p> <p>Open circuit in motor windings or power cable.</p> <p>Defective motor power cable.</p> <p>Motor defective.</p>	<p>Correct power source.</p> <p>Check power source for blown fuse, open circuit breaker, broken lead, or loose connection.</p> <p>Check continuity.</p> <p>Replace cable.</p> <p>Check for and replace defective unit.</p>
<p>CIRCUIT BREAKER TRIPS</p>	<p>Low or high voltage, or excessive voltage drop between pump and control box.</p> <p>Defective insulation in motor windings or power cable; defective windings.</p> <p>Impeller jammed due to debris or insufficient clearance.</p> <p>Bearing(s) frozen.</p>	<p>Measure voltage at control box. Check that wiring is correct type, size, and length. (See Field Wiring Connection, Section B).</p> <p>Check insulation resistance; check continuity.</p> <p>Disassemble pump and check impeller.</p> <p>Disassemble pump and check bearing(s).</p>

TROUBLE	POSSIBLE CAUSE	PROBABLE REMEDY
<p>MOTOR RUNS, BUT PUMP FAILS TO DELIVER RATED DISCHARGE</p>	<p>Discharge head too high.</p> <p>Low or incorrect voltage.</p> <p>Discharge throttling valve partially closed; check that valve is installed improperly.</p> <p>Discharge line clogged or restricted; hose kinked.</p> <p>Liquid being pumped too thick.</p> <p>Strainer screen or impeller clogged.</p> <p>Insufficient liquid in sump or tank.</p> <p>Worn impeller vanes; excessive impeller clearance.</p> <p>Pump running backwards.</p>	<p>Reduce discharge head, or install staging adaptor and additional pump.</p> <p>Measure control box voltage, both when pump is running and when shut off.</p> <p>Open discharge valve fully; check piping installation.</p> <p>Check discharge lines; straighten hose.</p> <p>Dilute liquid if possible.</p> <p>Clear clog(s). Stop pump; back flow may flush away debris.</p> <p>Stop pump until liquid level rises.</p> <p>Check impeller and clearance. See PUMP END REASSEMBLY.</p> <p>Check direction of rotation and correct by interchanging any two motor leads at control box. (See Pump Rotation, Section C).</p>
<p>PUMP RUNS WITH EXCESSIVE NOISE OR VIBRATION</p>	<p>Pumping entrained air.</p> <p>Damaged or unbalanced impeller.</p> <p>Discharge piping not properly supported.</p> <p>Impeller jammed or loose.</p> <p>Pump cavitation.</p> <p>Motor shaft or bearings defective.</p>	<p>Check liquid level in sump; check position of pump and liquid level sensing device(s).</p> <p>Replace impeller.</p> <p>Check piping installation.</p> <p>Check impeller.</p> <p>Reduce discharge head, or restrict flow on low head applications.</p> <p>Disassemble pump and check motor and bearings.</p>

ELECTRICAL TESTING

If you suspect that pump malfunctions are caused by defects in the motor, power cable or control box, perform the following checks to help isolate the defective part.



THE ELECTRICAL POWER USED TO OPERATE THIS PUMP IS HIGH ENOUGH TO CAUSE INJURY OR DEATH. OBTAIN THE SERVICES OF A QUALIFIED ELECTRICIAN TO TROUBLESHOOT, TEST AND/OR SERVICE THE ELECTRICAL COMPONENTS OF THIS PUMP.



BE CERTAIN TO REFER TO THE WIRING DIAGRAM(S) IN THE INSTALLATION SECTION OF THIS MANUAL BEFORE RECONNECTING ANY ELECTRICAL COMPONENTS WHICH HAVE BEEN DISCONNECTED.

Test Equipment

A volt/amp/ohmmeter to check AC voltage and current (amperage), and a megohmmeter of adequate range to measure resistance (ohms) to ground will be required to conduct the following electrical tests.

Voltage Imbalance

Each phase of the incoming three-phase power must be balanced with the other two as accurately as a commercial voltmeter will read. If the phases are balanced, check out the motor as described below. If the phases are out of balance, contact your power company and request that they correct the condition.

- a. Use a voltmeter, Amprobe, or equivalent meter to read the voltage across terminals 1 & 2, 2 & 3, and 1 & 3 in the control box. All three measured voltages must be the same, as ac-

curately as the meter will read. If possible, measure the voltage with the pump off, with the pump running but out of the water, and with the pump running in the water at full load. All the measured voltages at each condition must be the same.

- b. Use an Amprobe or equivalent meter to measure the current draw of each phase while the pump is running at full load and at no load. All three amperage readings must be the same at each condition, as accurately as the meter will read. Nominal amperage values are listed in Table 1, but these apply only when the actual voltage at the site is the nominal voltage listed.
- c. If the voltages are balanced with the pump off, but are unbalanced when the pump is running, a thorough check of the power source, all interconnecting cables, and the pump motor is required to isolate the defect.

Motor And Motor Power Cable Continuity

To check continuity, zero-balance the ohmmeter set at the RX1 scale, and test as follows:

- a. Disconnect the motor power cable leads from the control box and connect the test leads to any two of the power cable leads (not to the green ground lead or the yellow ground check lead(s)). If there is a high resistance reading on the ohmmeter, there is an open or broken circuit caused by a break in the power cable or motor windings, or by a bad connection between the motor and the power cable. Switch one test lead to the third power lead, and test again.
- b. If an open or broken circuit is indicated, check the power cable for obvious damage, and replace as necessary (see **MAINTENANCE AND REPAIR**). If there is no apparent damage to the motor cable, remove the terminal housing (see **MAINTENANCE AND REPAIR**) and check the continuity of each power cable lead at the terminal posts.
- c. If an open circuit still exists after each lead (terminal) has been tested and tightened, then the **entire** motor power cable must be replaced. Splicing or other means of repair are not recommended.

- d. If no break is found in the power cable, check the motor leads for continuity. If the test reading indicates an open or broken circuit, there is an open circuit in the motor.

NOTE

It is recommended that a pump with a defective motor be returned to Gorman-Rupp, or to one of the Gorman-Rupp authorized Submersible Repair Centers.

Insulation Resistance

To check insulation, zero-balance the ohmmeter set at the RX100K scale, and test as follows:

- a. Disconnect the motor power cable leads from the control box. Connect one test lead to the

power cable green ground lead, and touch the other test lead to each of the three power leads in turn.

- b. The reading obtained will indicate resistance values in both the power cable and the motor windings. If the resistance reading is infinity (∞), the insulation is in good condition. If the reading is between infinity (∞) and 1 megohm, the insulation is acceptable but should be rechecked periodically. If the reading is less than 1 megohm, the insulation should be checked more closely; a reading of zero indicates that the power cable or the motor is grounded.
- c. To determine whether the power cable or the motor is grounded, remove the terminal housing (MAINTENANCE AND REPAIR), disconnect the motor leads from the motor terminals, and test the power cable leads and motor leads separately.

PUMP MAINTENANCE AND REPAIR - SECTION E

MAINTENANCE AND REPAIR OF THE WEARING PARTS OF THE PUMP WILL MAINTAIN PEAK OPERATING PERFORMANCE.

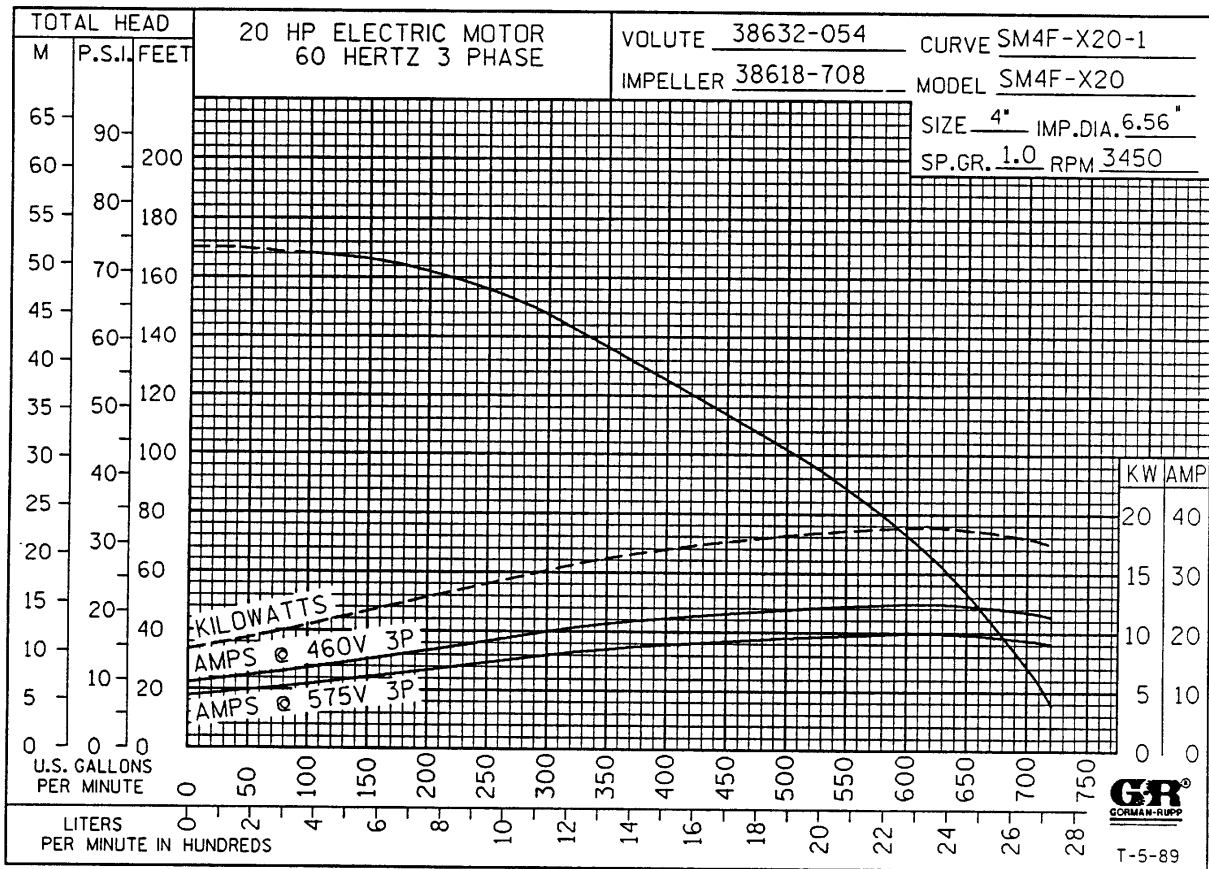

*** STANDARD PERFORMANCE FOR PUMP MODELS
SM4F (ALL MATERIALS AND VOLTAGES)**

* Based on 70° F (21° C) clear water at sea level. Since pump installations are seldom identical, your performance may be difference due to such factors as viscosity, specific gravity, elevation, temperature, and impeller trim.

If your pump serial number is followed by an "N", your pump is **NOT** a standard production model. Contact the Gorman-Rupp Company to verify performance or part numbers.

SECTION DRAWING

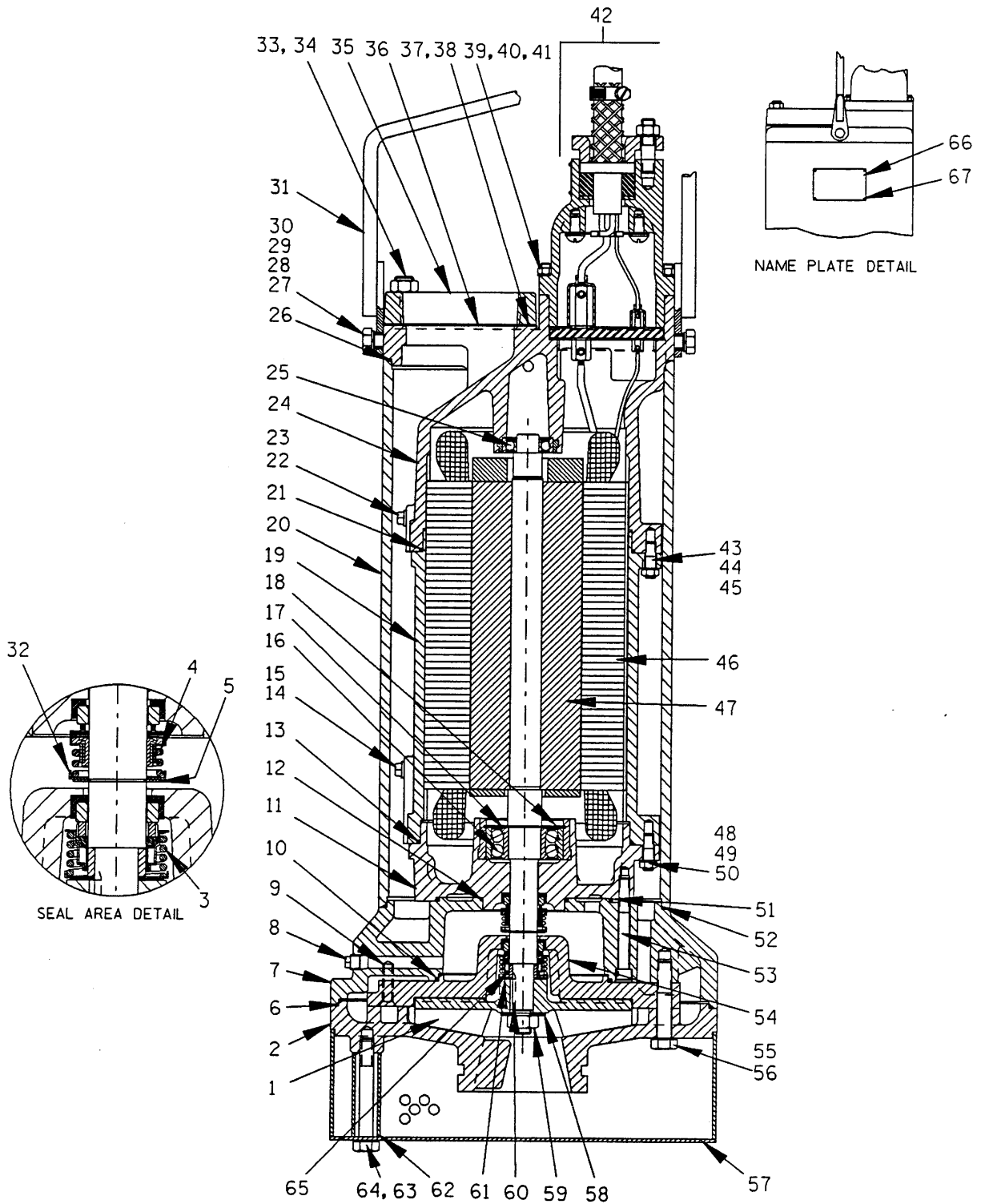

Figure 1. Pump Models SM4F1-X20 460/3 & SM4F1-X20 575/3

SECTION DRAWING

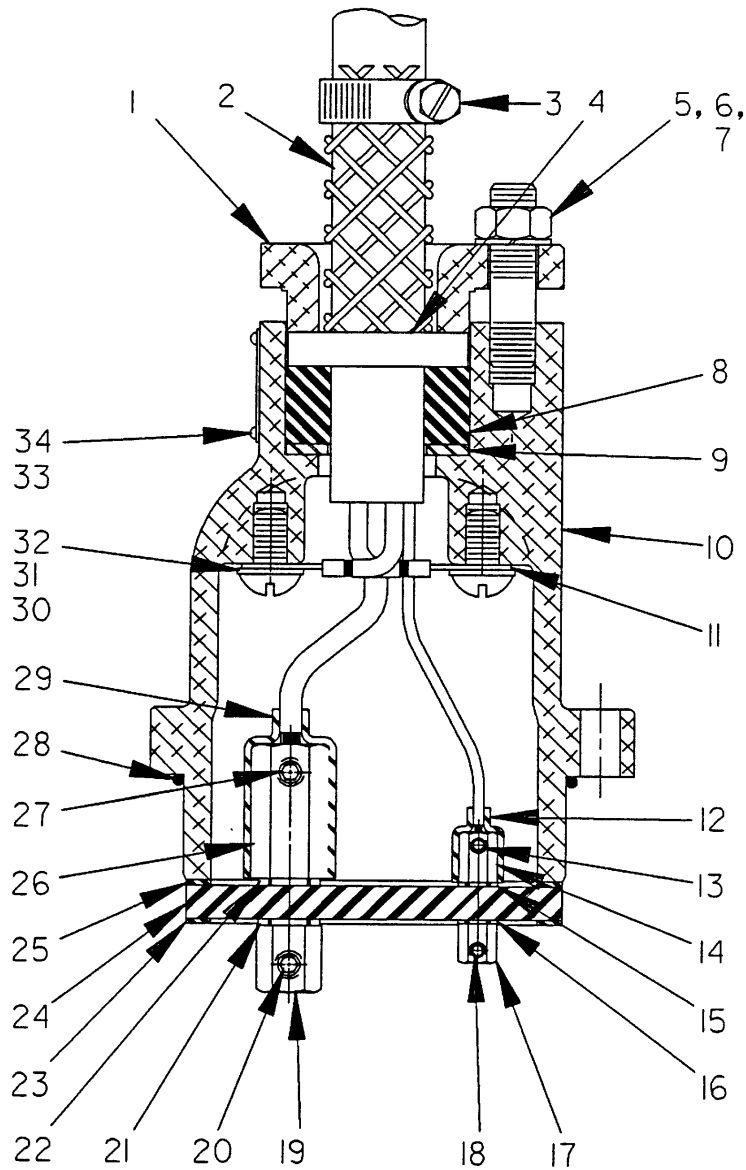

Figure 2. 47367-075 Terminal Housing And Cable Assembly

PARTS LIST
47367-075 Terminal Housing And Cable Assembly

ITEM NO.	PART NAME	PART NUMBER	MAT'L CODE	QTY
1	TERMINAL GLAND	11367	13040	1
2	* POWER CABLE	47325-010	-----	1
3	HOSE CLAMP	26518-666	-----	1
4	CABLE GRIP	11227-L	-----	1
5	STUD	C0808	17000	2
6	HEX NUT	D08	17000	2
7	LOCKWASHER	J08	17000	2
8	* GLAND BUSHING	10758-K	19410	1
9	TERMINAL WASHER	10659	15991	1
10	TERMINAL HOUSING	38381-226	13000	1
11	TERMINAL	27214-035	-----	1
12	HEAT SHRINK TUBE	31412-056	19530	2
13	ALLEN HEAD SETSCREW	GA#10-01-S	15991	2
14	TERMINAL COLLAR	31811-057	14100	2
15	* UPPER DYNA SEAL WASHER	S1590	-----	2
16	* LOWER DYNA SEAL WASHER	S1590	-----	2
17	TERMINAL POST	11181	14100	2
18	ALLEN HEAD SETSCREW	GA#10-01-S	15991	2
19	TERMINAL POST	38724-009	14100	3
20	ALLEN HEAD SETSCREW	GA#0501-1/2	14990	3
21	* LOWER DYNA SEAL WASHER	S1586	-----	3
22	* UPPER DYNA SEAL WASHER	S1586	-----	3
23	* LOWER TERMINAL PLATE GASKET	38687-529	20000	1
24	TERMINAL PLATE	38711-001	23010	1
25	* UPPER TERMINAL PLATE GASKET	38687-529	20000	1
26	TERMINAL COLLAR	10144	14100	3
27	ALLEN HEAD SETSCREW	GA0501-1/2	14990	3
28	* O-RING	25154-155	-----	1
29	HEAT SHRINK TUBE	31413-014	19530	3
30	TERMINAL	S1550	-----	1
31	RD HD MACH SCREW	X0603	14990	2
32	T TYPE LOCKWASHER	AK06	15991	2
33	DRIVE SCREW	BM#04-03	17000	4
34	CERTIFICATION PLATE	2613-GX	17020	1
NOT SHOWN:				
	1 OZ. HOT MELT ADHESIVE STICK	18661-045	-----	2

* INDICATES PARTS RECOMMENDED FOR STOCK

PUMP AND SEAL DISASSEMBLY AND REASSEMBLY

Review all warnings in Section A.

Follow the instructions on all tags, label and decals attached to the pump.

All functions performed by the customer on the pump or control must be done in accordance with MSHA, schedule 2G regulations to ensure the explosion-proof integrity. No alterations of original design may be made without the consent of the Gorman-Rupp Company and MSHA.

The following maintenance and repair instructions are keyed to the Pump Model sectional view (Figure 1) and the Terminal Housing sectional view (Figure 2), and the accompanying parts lists.



THE ELECTRICAL POWER USED TO OPERATE THIS PUMP IS HIGH ENOUGH TO CAUSE INJURY OR DEATH. MAKE CERTAIN THAT THE CONTROL HANDLE ON THE CONTROL BOX IS IN THE OFF POSITION AND LOCKED OUT, OR THAT THE POWER SUPPLY TO THE CONTROL BOX HAS BEEN OTHERWISE CUT OFF AND LOCKED OUT, BEFORE ATTEMPTING TO OPEN OR SERVICE THE PUMP ASSEMBLY. TAG ELECTRICAL CIRCUITS TO PREVENT ACCIDENTAL START-UP.



DO NOT OPEN THE CONTROL BOX IN AN EXPLOSIVE ATMOSPHERE. WHEN SEALED, THE CONTROL BOX IS EXPLOSION PROOF TO PREVENT THE IGNITION OF COMBUSTIBLE GASES. OPENING THE BOX IN AN EXPLOSIVE ATMOSPHERE COULD RESULT IN FIRE OR EXPLOSION.

Before attempting to service the pump or control, terminate the power supply to the control box. Close the discharge throttling valve, if so equipped.

Use the hoisting bail to remove the pump from the wet well or sump, and move it to a location where the discharge line can be removed. It is not necessary to disconnect a flexible discharge hose before removing the pump. If rigid discharge piping is used, disconnect the piping before attempting to move the pump.



DO NOT ATTEMPT TO LIFT THE PUMP BY THE MOTOR POWER CABLE OR THE PIPING. ATTACH PROPER LIFTING EQUIPMENT TO THE LIFTING DEVICE FITTED TO THE PUMP. IF CHAINS OR CABLE ARE WRAPPED AROUND THE PUMP TO LIFT IT, MAKE CERTAIN THAT THEY ARE POSITIONED SO AS NOT TO DAMAGE PUMP, AND SO THAT THE LOAD WILL BE BALANCED.

Select a suitable location, preferably indoors, to perform the degree of maintenance required. If the motor housing is to be opened, the work must be done in a clean, well-equipped shop. All maintenance functions must be done by qualified personnel.

Check the chart in TROUBLESHOOTING, Section D, to determine the nature of the pump problem. If the problem is mechanical in nature, such as worn pump parts, seal replacement, lubrication, etc., refer to PUMP END DISASSEMBLY for instructions.

If the problem is electrical, complete disassembly may not be required. Refer to Electrical Testing in TROUBLESHOOTING, Section D, and have a qualified electrician check the control box, cable and terminal housing. If the problem is determined to be in the motor, proceed with PUMP END DISASSEMBLY, followed by MOTOR DISASSEMBLY. Otherwise, see Terminal Housing And Power Cable Disassembly.

Carefully inspect any O-rings or gaskets before removal and cleaning to determine if a proper seal and compression existed prior to disassembly. If sealing was faulty or questionable, the cause must be determined and corrected before reassembly. All gaskets and most O-rings must be replaced if disturbed. Repair gaskets and O-rings are listed on the parts list.

PUMP END DISASSEMBLY

Strainer Removal

(Figure 1)

To remove the strainer (57), raise the pump slightly, or lay it on its side and disengage the strainer hardware (63 and 64). Remove the strainer and supports (62). If the impeller is clogged, the debris can usually be removed without further disassembly.

Draining Oil From Seal Cavity

(Figure 1)

If any further disassembly is to be performed on the pump, the seal oil cavity must be drained.



LET THE PUMP COOL BEFORE REMOVING THE SEAL CAVITY DRAIN PLUG. PRESSURE BUILT UP WITHIN A HOT PUMP COULD CAUSE THE OIL TO SPRAY OUT WHEN THE PLUG IS REMOVED. REMOVE THE PLUG SLOWLY AND PERMIT PRESSURE TO VENT TO ATMOSPHERE.

Lay the pump on its side with the seal cavity drain plug (8) facing up. Clean any dirt from around the plug before removing it. Remove the plug, and install a short 1/4-inch NPT nipple in the hole. Tip the pump and drain the seal oil into a clean container. Inspect the oil for water, dirt, or cloudy condition which could indicate lower seal failure or poor gasket seal.

Positioning Pump For Disassembly

(Figure 1)

It is recommended that the pump be positioned upside-down during disassembly. To hold the pump in the inverted position, screw a pipe in the discharge flange (35) and clamp it in a large vise, or remove the discharge flange and secure the flange studs to a bench or work stand. The pump may also be rested securely on blocks. Be careful not to damage the terminal housing or cable while in this posi-

tion. Use adequate equipment and personnel to safely handle the pump until it is secured. If inverting the pump is not practical, lay the pump on its side and secure it to prevent rolling.

Diffuser Removal

(Figure 1)

Remove the hardware (55 and 56) securing the diffuser (2) to the seal plate (54) and intermediate (7). Remove the diffuser, and remove and discard the diffuser O-ring (6).

Impeller Removal

(Figure 1)

Temporarily reinstall two of the capscrews (55). Wedge a piece of wood between the vanes of the impeller (1) and the capscrews to prevent shaft rotation. Remove the impeller locknut (59) and washer (58).

Remove the wood from the impeller vanes, and remove the capscrews (55) temporarily installed in the seal plate and intermediate. Install the impeller puller supplied with the pump, and pull the impeller from the shaft. Use caution when removing the impeller; tension on the seal spring will be released. Retain the impeller key (60).

Remove the impeller adjusting shims (61); tie and tag the shims, or measure and record their thickness for ease of reassembly.

Lower Seal Removal

(Figures 1 and 3)

Remove the seal spring. Carefully slide the spacer sleeve (65) and rotating portion of the seal off the shaft. Lubricate the spacer sleeve, and work oil up under the rubber bellows. Carefully slide the rotating portion of the lower seal assembly off the spacer sleeve.

To remove the stationary portion of the seal, remove the flat head machine screws (9), and slide the seal plate (54) off the shaft. Remove and discard the seal plate O-ring (10).

Place the seal plate on a flat surface with the impeller side down. Use a dowel to press the stationary cup and seat out of the seal plate.

An alternate method of removing the stationary portion of the seal without removing the seal plate is to slide a pair of stiff wires with hooked ends along the shaft and hook the stationary seat from the back side. Use the wires to pull the stationary portion of the seal from the seal plate.

The rotating and stationary seal elements are precision finished and subject to wear. The complete seal should be replaced with each overhaul to ensure trouble-free operation. However, if the old seal must be reused, wrap the seal faces individually in clean tissue paper to prevent damage to the sealing surfaces.

If no further disassembly is required, proceed to the appropriate areas in **PUMP END REASSEMBLY**.

Upper Seal Removal

(Figures 1 and 3)

Unless cracked, worn, or O-ring replacement is required, it is not necessary to remove the intermediate (7) for access to the upper seal assembly (4).

If intermediate removal is desired, disengage the socket head capscrews (53) and separate the intermediate from the lower motor housing (11). Remove the intermediate, and remove and discard the O-rings (12, 51 and 52). Remove the pump casing (20) and discard the O-ring (26).

Remove the seal retaining ring (5) with snap ring pliers. Use caution when removing the retaining ring; tension on the seal spring will be released. Remove the seal spring holder (32) and spring. Lubricate the shaft adjacent to the seal, and work oil up under the rubber bellows. Position a screwdriver or other suitable device on each side of the bellows retaining flange, and pry the bellows upward until the rotating portion is off the shaft.

Slide the hook ends of two wires along the shaft and under the stationary seal seat. Hook the back side of the seat, and pull the seat and stationary element from the lower motor housing (11).

With the pump inverted, stuff a clean tissue into the seal bore of the lower motor housing (or wrap a small rag around the shaft) to prevent foreign material from entering the motor cavity.

NOTE

*Do not disassemble the motor unless it is necessary, and a clean, well-equipped shop is available. If the motor housing components are to be serviced, see **MOTOR DISASSEMBLY** in this section. Do not reassemble the pump end components at this time.*

If no further disassembly is required, proceed to **PUMP END REASSEMBLY**.

PUMP END REASSEMBLY

NOTE

Reuse of old O-rings, gaskets, or shaft seal parts may result in premature leakage or reduced pump performance. It is strongly recommended that new gaskets and shaft seal assemblies be used during reassembly (see the parts lists for numbers).

Cleaning And Inspection Of Pump Parts

(Figure 1)

Carefully inspect any O-rings or gaskets before removal and cleaning to determine if a proper seal and compression existed prior to disassembly. If sealing was faulty or questionable, the cause must be determined and corrected before reassembly. Replace any parts as required.

Thoroughly clean all reuseable parts with a soft cloth soaked in cleaning solvent. Use a clean cloth lightly dampened with solvent to clean the lower motor housing, intermediate, and seal plate. **Do not** allow the solvent to enter the motor.



MOST CLEANING SOLVENTS ARE TOXIC AND FLAMMABLE. USE THEM ONLY IN A WELL-VENTILATED AREA FREE FROM EXCESSIVE HEAT, SPARKS, AND FLAME. READ AND FOLLOW ALL PRECAUTIONS PRINTED ON SOLVENT CONTAINERS.

Remove all O-rings and gaskets, and clean the sealing surfaces of dirt or gasket material. Be careful not to scratch gasket surfaces.

Inspect the rotor shaft for damaged threads, scoring, or nicks. Remove nicks and burrs with a fine file or hand honing stone to restore original contours. If the shaft is bent or severely damaged, the rotor and shaft must be replaced as an assembly (see **MO-TOR DISASSEMBLY**).

Handle the seal parts with extreme care to prevent damage. Be careful not to contaminate the precision finished faces; even fingerprints on the faces can shorten seal life. If necessary, clean the faces with a non-oil based solvent and a clean, lint-free tissue. Wipe **lightly** in a concentric pattern to avoid scratching the faces.

Neither of the shaft seal assemblies should be re-used because wear patterns on the finished faces cannot be realigned during reassembly. This could result in premature failure. If necessary to reuse an old seal in an emergency, **carefully** wash all metallic parts in fresh cleaning solvent and allow to dry thoroughly.

Inspect the seal components for wear, scoring, grooves, and other damage that might cause leakage. If any components are worn, replace the complete seal; **never mix old and new seal parts**.

Install the shaft seals as illustrated in Figure 3.

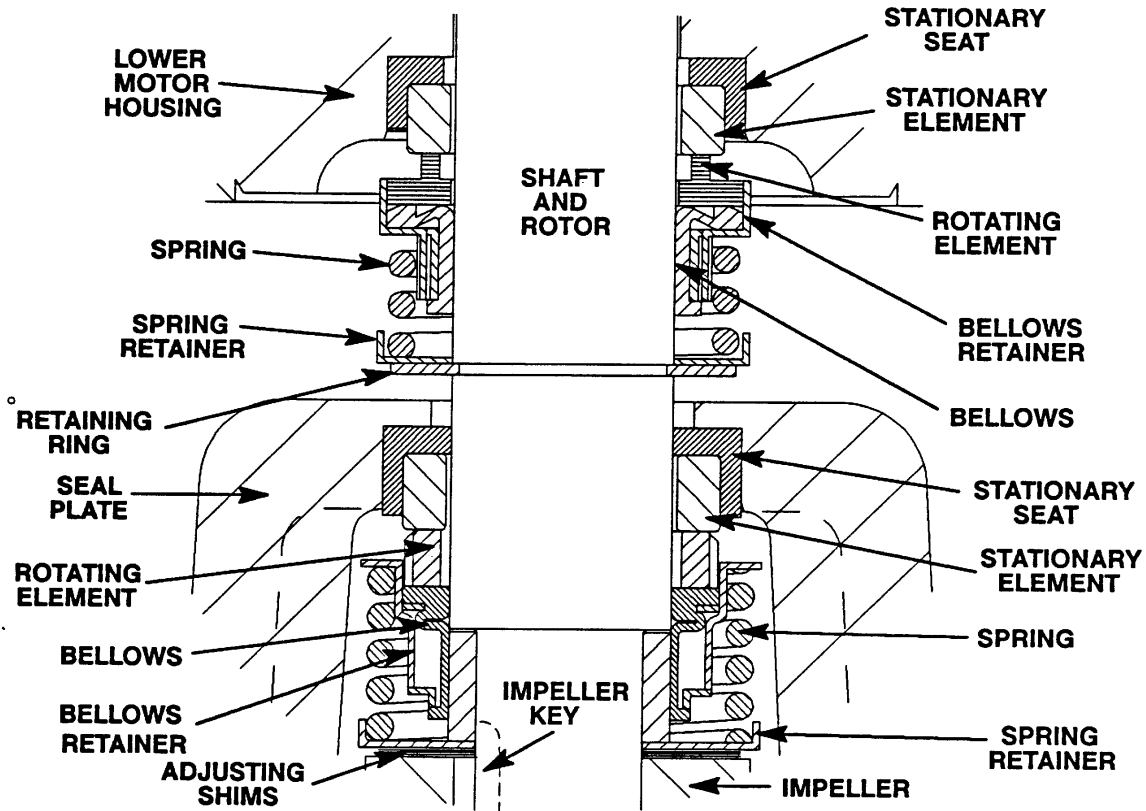

Figure 3. 46512-057 (Lower) And 25271-866 (Upper) Seal Assemblies



THIS SEAL IS NOT DESIGNED FOR OPERATION AT TEMPERATURES ABOVE 160° F. DO NOT USE AT HIGHER OPERATING TEMPERATURES.

Upper Seal Installation

(Figures 1 and 3)

If a new upper seal assembly is to be installed, do not unwrap it until time of installation. Cleanliness of seal components is critical, especially the seal faces.

Carefully remove the material stuffed into the seat bore (or unwrap the shaft). **Be sure** no debris stopped by the material falls into the motor cavity.

Clean the rotor shaft and seal cavity area of the lower motor housing. Be sure the area is dry and free of lint and dirt. **Do not** permit cleaning solvent or debris to fall into the motor cavity. Check the seal bore for burrs or nicks that might prevent a good seal. Apply a **light** coating of oil to the bore.

Unpack the stationary seat and element. Apply a **light** coating of oil to the stationary seat. Keep the sealing face dry.

NOTE

When pressing seal components onto the impeller shaft, use hand pressure only. A push tube cut from a length of plastic pipe will aid in installing seal components. The I.D. of the push tube should be approximately the same as the I.D. of the seal spring.

Position the seat in the bore with the sealing face up, and cover it with a clean tissue. Use your thumbs to press the seal into the bore. Apply equal pressure on opposite sides of the sealing elements until it is fully seated in the bore. Remove the tissue and inspect the seal face to ensure that it is clean and dry. If cleaning is necessary, use clean tissue to wipe **lightly** in a concentric pattern.

Unpack the rotating portion of the seal. Be certain the seal face of the rotating element is free of grit or surface damage. Place a **small** amount of grease at equal spaces on the back of the element, and assemble the drive grooves of the rotating element into the drive lugs of the bellows retainer. The grease should hold the element in position until the seal is installed.

Apply a light coating of oil to the seal seating surface on the shaft, the groove for the retaining ring (5), and the I.D. of the bellows. Apply a single drop of light lubricating oil to the precision-finished seal face. Position the rotating seal portion on the shaft with the seal face down. Apply firm, steady pressure on the bellows retainer until it slides down the shaft and the seal faces contact. This step should be done in one continuous motion to prevent the bellows from sticking or rolling as it passes over the retaining ring groove.

Slide the seal spring over the shaft and bellows retainer, and install the spring retainer (32). Install the seal retaining ring (5). See Figure 3 for proper order of seal assembly.

Lower Seal Installation

(Figure 1)

Thoroughly clean the sealing surfaces and seal bore of the the seal plate (54). The seal bore must be free of burrs and nicks which could damage the seal.

NOTE

When pressing seal components onto the impeller shaft, use hand pressure only. A push tube cut from a length of plastic pipe will aid in installing seal components. The I.D. of the push tube should be approximately the same as the I.D. of the seal spring.

If the intermediate (7) was removed, lubricate the O-rings (12, 51 and 52) with light oil, and install them on the intermediate and lower motor housing (11). Apply 'Never-Seez' or equivalent compound on the threads of the socket head capscrews (53), and secure the intermediate to the lower motor housing by torquing the capscrews to 22 ft. lbs. (264 in. lbs. or 3.04 m. kg.).

Unpack the stationary seat and element. Apply a **light** coating of oil to the stationary seat. Keep the sealing face dry.

Position the seal plate on a flat surface with the impeller side up. Position the seat in the bore with the sealing face up, and cover it with a clean tissue. Use your thumbs to press the seal into the bore. Apply equal pressure on opposite sides of the sealing elements until it is fully seated in the bore. Remove the tissue and inspect the seal face to ensure that it is clean and dry. If cleaning is necessary, use clean tissue to wipe **lightly** in a concentric pattern.

Lubricate the O-ring (10) with light oil, and install it on the seal plate shoulder. Carefully position the seal plate and assembled stationary portion of the seal over the shaft and against the intermediate. **Be careful** not to damage the stationary element. Secure the seal plate to the intermediate with the flat head machine screws (9).

Unpack the rotating portion of the seal. Be certain the seal face of the rotating element is free of grit or

surface damage. Place a **small** amount of grease at equal spaces on the back of the element, and assemble the drive grooves of the rotating element into the drive lugs of the bellows retainer. The grease should hold the element in position until the seal is installed.

Clean and polish the shaft sleeve (65), or replace it if there are nicks or cuts on either end. Apply a light coating of oil to the sleeve and rotor shaft, and slide the sleeve onto the shaft until the chamfered end seats squarely against the shaft shoulder.

Apply a light coating of oil on the I.D. of the bellows. Apply a single drop of **light** lubricating oil to the precision-finished seal face. Position the rotating seal portion on the shaft with the seal face down. Apply firm, steady pressure on the bellows retainer until it slides down the shaft and the seal faces contact.

Slide the seal spring over the shaft and bellows retainer. See Figure 3 for proper order of seal assembly.

Impeller Installation

(Figure 1)

Inspect the impeller for cracks, broken vanes, or wear from erosion, and replace it if damaged. Inspect the diffuser (2) and replace it if defective.

Install the same thickness of impeller adjusting shims (61) as previously removed onto the rotor shaft. Install the impeller key (60) in the rotor shaft keyway, align the impeller keyway, and press the impeller onto the shaft until it seats firmly against the adjusting shims.

For maximum pump efficiency, there should be a clearance of .008 to .015 inch (0,2 to 0,4 mm) between the diffuser and the face of the impeller. The impeller must be fully seated in the shaft to determine this clearance. Install the impeller washer (58) and nut (59). Install two capscrews (55) in the seal plate and diffuser. Wedge a block of wood between the impeller vanes and capscrews to prevent shaft rotation, and torque the impeller locknut to 120 ft. lbs. (1440 in. lbs or 16,6 m. kg.).

Remove the capscrews (55), and position the diffuser against the seal plate. Reach through the diffuser

opening with a feeler gauge and measure the impeller face clearance.

Adjust the clearance by adding or removing adjusting shims (61) as required.

When the impeller is properly positioned, reinstall the capscrews (55), secure the impeller to prevent rotation, and remove the impeller nut. Coat the threads of the rotor shaft with 'Loctite Threadlocker No. 242' or equivalent compound, and re-torque the impeller nut.

NOTE

After the impeller has been properly positioned, check for free rotation. Correct any scraping or binding before further reassembly.

Install the O-ring (6) on the diffuser and secure it to the seal plate and intermediate with the hardware (55 and 56).

Strainer Installation

(Figure 1)

Inspect the strainer screen for cracks or broken welds. Straighten or reweld as required.

Install the support pipes (62) and strainer (57), and secure it with the hardware (63 and 64). Tighten the capscrews just enough to draw the strainer screen down tightly, but not tight enough to distort it.

See **LUBRICATION** and **FINAL ASSEMBLY** before putting the pump back into service.

MOTOR DISASSEMBLY

Disassembly of the motor is rarely required except to replace the motor rotor, stator or bearings. Do not disassemble the motor unless it is necessary and a clean, well-equipped shop is available.

NOTE

It is recommended that a pump with a defective motor be returned to Gorman-Rupp, or to one of the Gorman-Rupp authorized Submersible Repair Centers.



MOTOR REPAIRS MUST BE PERFORMED IN ACCORDANCE WITH MSHA SPECIFICATIONS REGARDING THE PERMISSIBILITY OF THIS EQUIPMENT. REFER TO INSTALLATION, PAGE B-1.



THE ELECTRICAL POWER USED TO OPERATE THIS PUMP IS HIGH ENOUGH TO CAUSE INJURY OR DEATH. MAKE CERTAIN THAT THE CONTROL HANDLE ON THE CONTROL BOX IS IN THE OFF POSITION AND LOCKED OUT, OR THAT THE POWER SUPPLY TO THE CONTROL BOX HAS BEEN OTHERWISE CUT OFF AND LOCKED OUT, BEFORE ATTEMPTING TO OPEN OR SERVICE THE PUMP ASSEMBLY. TAG ELECTRICAL CIRCUITS TO PREVENT ACCIDENTAL START-UP.



DO NOT REMOVE THE CONTROL BOX COVER IN AN EXPLOSIVE ATMOSPHERE. WHEN SEALED, THE CONTROL BOX IS EXPLOSION PROOF TO PREVENT THE IGNITION OF COMBUSTIBLE GASES. OPENING THE BOX IN AN EXPLOSIVE ATMOSPHERE COULD CAUSE FIRE OR EXPLOSION.

Carefully inspect any O-rings or gaskets before removal and cleaning to determine if a proper seal and compression existed prior to disassembly. If sealing was faulty or questionable, the cause must be determined and corrected before reassembly. Replace any parts as required.

Terminal Housing And Power Cable Removal And Disassembly

(Figure 1)

Total disassembly of the terminal housing and power cable is not always required. Disassemble and replace only the parts proven defective by in-

spection or testing. See **Electrical Testing in TROUBLESHOOTING**.

The terminal housing and power cable may be serviced without disassembling the motor housing or pump end.



DO NOT REMOVE THE TERMINAL HOUSING IN AN EXPLOSIVE ATMOSPHERE. THE TERMINAL HOUSING AND ITS O-RING MUST REMAIN INTACT TO RETAIN THE PERMISSIBILITY OF THIS EQUIPMENT. REMOVING THE HOUSING IN AN EXPLOSIVE ATMOSPHERE COULD CAUSE FIRE OR EXPLOSION.

Secure the pump in an upright position. To remove the terminal housing, disengage the hardware (40 and 41) securing the terminal housing assembly (42) to the upper motor housing (24).

(Figure 2)

Carefully raise the terminal housing from the motor housing until the terminal posts (17 and 19) are accessible. Loosen the allen head setscrews (18 and 20), and disconnect the motor leads from the terminal posts. Separate the terminal housing and power cable assembly from the motor housing. Remove the lower terminal housing gasket (23).

Remove the O-ring (28) from the terminal housing. No further disassembly is required to test the stator or power cable.

Remove the hose clamp (3) from the cable grip (4). Disengage the hardware (6 and 7), and slide the terminal gland (1) back along the power cable.

Compress the wire mesh of the cable grip and move it back along the power cable. Oil the gland bushing (8) and terminal housing bore and push firmly on the cable. (Allow the oil to leak in around the bushing by agitating the cable in the bore.) After the bushing has been loosened, it should be possible to push the cable into the terminal housing so that the terminal plate (24) comes free of the terminal housing. This should permit access to the power cable connections in the terminal plate.

NOTE

Sometimes pressure exerted on the gland bushing (8) will deform the power cable jacket. If this occurs,

additional oil and effort will usually free the power cable. If the cable cannot be separated from the gland bushing, it may be necessary to cut the cable.

The connections between the power cable leads and the terminal collars (14 and 26) were encapsulated in heat-shrink tubing (12 and 29) and bonded to the terminal plate with hot-melt adhesive. Cut away the tubing and adhesive, and loosen the allen head setscrews (13 and 27). Disconnect the power cable leads from the terminal collars, and separate the terminal plate from the terminal housing (10). Remove the upper terminal plate gasket (25).

To remove the power cable from the terminal housing, disengage the hardware (31 and 32), and disconnect the green and yellow ground leads from the terminal housing. Slide the power cable out of the terminal housing. The terminal gland (1) and cable grip (4) can now be removed from the cable.

To remove the gland bushing (8), work oil in around the bushing. Invert the terminal housing, and press the bushing and terminal washer (9) out of the bore from the back side.

NOTE

If the rubber bushing cannot be removed from the terminal housing as indicated, it may be necessary to cut the bushing into small pieces.

If it is necessary to replace the terminal plate (24) or terminal components, unscrew the terminal collars (14 and 26), and remove the collars, dyna seal washers (15, 16, 21 and 22), and terminal posts (17 and 19).

Shaft And Rotor Removal

(Figure 1)

See **PUMP END DISASSEMBLY**, and remove all pump end and seal components (including the lower motor housing, rotor and shaft assembly).

With the pump end disassembled and the terminal housing removed, secure the pump in an inverted position.

If the intermediate (7) was not removed during pump end disassembly, disengage the socket head cap-screws (53) and remove the intermediate at this time. Remove the O-rings (12, 51 and 52) and the pump casing (20) and O-ring (26).

Remove the hardware (49 and 50). Slide the assembled lower motor housing (11), shaft and rotor (47), and bearings (16 and 25) out of the stator (46) and upper motor housing (24).

Remove the retaining ring (18), and slide the lower motor housing off the lower bearing.

NOTE

If necessary, tap around the edge of the lower motor housing with a soft-faced mallet or a block of wood to separate the motor housing from the bearing.

Before removing the bearings from the rotor shaft, clean and inspect the bearings **in place** as follows.



TO PREVENT DAMAGE DURING REMOVAL FROM THE SHAFT, IT IS RECOMMENDED THAT BEARINGS BE CLEANED AND INSPECTED IN PLACE. IT IS STRONGLY RECOMMENDED THAT THE BEARINGS BE REPLACED ANY TIME THE SHAFT AND ROTOR ASSEMBLY IS REMOVED.

Clean the bearings thoroughly in **fresh** cleaning solvent. Dry the bearings with filtered compressed air and coat with light oil.



MOST CLEANING SOLVENTS ARE TOXIC AND FLAMMABLE. USE THEM ONLY IN A WELL-VENTILATED AREA FREE FROM EXCESSIVE HEAT, SPARKS, AND FLAME. READ AND FOLLOW ALL PRECAUTIONS PRINTED ON SOLVENT CONTAINERS.

Rotate the bearings by hand to check for roughness or binding. If rotation is rough, replace the bearings.



THESE BEARINGS ARE PERMANENTLY SEALED AND REQUIRE NO ADDITIONAL LUBRICATION EXCEPT A COATING OF LIGHT OIL ON EXTERNAL SURFACES TO EASE REASSEMBLY. EXTERNAL SURFACES MUST BE KEPT FREE OF ALL DIRT AND FOREIGN MATERIAL. FAILURE TO DO SO COULD DAMAGE THE BEARINGS OR THEIR MATING SURFACES.

The bearing tolerances provide a tight press fit onto the shaft and a snug slip fit into the upper and lower motor housings. Replace the shaft and rotor (as an assembly), or the upper and lower motor housings if the proper bearing fit is not achieved.

If the bearings require replacement, use a suitable puller to remove them from the shaft.

It is not necessary to remove the retaining ring (17) from the shaft unless replacement is required. Use snap ring pliers to remove the retaining ring.

If no further disassembly is required, cover the middle and upper motor housings with a clean, lint-free cloth to avoid contamination of the stator by dirt or other foreign material.

Stator Removal

(Figure 1)

Do not remove the stator (4) unless it is defective (open windings, insulation resistance low, or stator core damaged). If the stator must be removed, remove the terminal housing as indicated in **Terminal Housing And Power Cable Disassembly**.

Remove the pipe plugs (14 and 22) and loosen the allen head setscrews (15 and 23).

Position an expandable tool, such as a split disc, approximately 2 inches (51 mm) down inside the stator, and expand it tightly and squarely on the I.D. Attach a lifting device to the lifting eye of the tool, and raise the assembly approximately 1 inch (25 mm) off the work surface. Take care not to damage the stator end turns. Use a soft-faced mallet to rap alternate edges of the upper motor housing and "walk" the stator out. Continue this process until the stator clears the motor housing.

NOTE

It may be necessary to heat the motor housings to permit stator removal. Apply heat evenly to the outside of the housings; excessive heat is not required.

After the stator has been removed, wrap it in clean, dry rags or other suitable material. The stator **must** be kept clean and dry. When handling the stator, **do not** set it on the end windings; lay it on its side.



DO NOT ATTEMPT TO REWIND THE STATOR. WINDING TOLERANCES AND MATERIALS ARE CLOSELY CONTROLLED BY THE MANUFACTURER, AND ANY DEVIATION CAN CAUSE DAMAGE OR OPERATING PROBLEMS. REPLACE THE STATOR, OR RETURN IT TO ONE OF THE GORMAN-RUPP AUTHORIZED SUBMERSIBLE REPAIR CENTERS OR THE GORMAN-RUPP FACTORY, IF DEFECTIVE.

It is not necessary to separate the upper and middle motor housings unless replacement of the O-ring (21) or one of the motor housings is required. Remove the hardware (44 and 45) to separate the motor housings, and remove and discard the O-ring.

Hoisting Bail

(Figure 1)

If the hoisting bail (31) requires replacement, remove the hardware (28, 29 and 30) securing the bail to the upper motor housing. Remove the bushings (27).

MOTOR REASSEMBLY

NOTE

Reuse of old O-rings, gaskets, shaft seal parts may result in premature leakage or reduce pump performance. It is strongly recommended that new gaskets and shaft seal assemblies be used during reassembly (see the parts lists for numbers).

Stator Installation

(Figure 1)



DO NOT ATTEMPT TO REWIND THE STATOR. WINDING TOLERANCES AND MATERIALS ARE CLOSELY CONTROLLED BY THE MANUFACTURER, AND ANY DEVIATION CAN CAUSE DAMAGE OR OPERATING PROBLEMS. REPLACE THE STATOR, OR RETURN IT TO ONE OF THE GORMAN-RUPP AUTHORIZED SUBMERSIBLE REPAIR CENTERS OR THE GORMAN-RUPP FACTORY, IF DEFECTIVE.

Clean all gasket and O-ring surfaces, completely removing any old gasket and cement material. Inspect the sealing surfaces for burrs, nicks and pits which could cause a poor seal, and replace defective parts as required.

If the upper and middle motor housings (19 and 24) were separated at disassembly, install a new O-ring (21) and secure the motor housings together with the hardware (44 and 45). Coat the threads of the studs (43) with 'Never-Seez' or equivalent compound, and torque the nuts to 20 ft. lbs. (240 in. lbs. or 2,8 m. kg.).

Thoroughly clean the inside of the motor housings (19 and 24) with fresh solvent. The interior **must** be dry and free of dirt or lint.

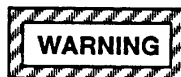

MOST CLEANING SOLVENTS ARE TOXIC AND FLAMMABLE. USE THEM ONLY IN A WELL-VENTILATED AREA FREE FROM EXCESSIVE HEAT, SPARKS, AND FLAME. READ AND FOLLOW ALL PRECAUTIONS PRINTED ON SOLVENT CONTAINERS.

After the motor housings are thoroughly cleaned, position them on a flat surface with the upper motor housing down. Do not unwrap the stator until the motor housing has been prepared for stator installation. The stator **must** be kept clean and dry. When handling the stator, do not set it on the end windings. Lay it on its side and block it from rolling.

Test the new stator as indicated in **Electrical Testing in TROUBLESHOOTING**, Section D, to ensure that no damage has occurred during transit or handling.

NOTE

Remove any drops of varnish from the ends of the stator before installation to ensure proper stack-up height when assembled.

Position an expandable tool, such as a split disc, approximately 2 inches down inside the stator, and expand it tightly and squarely on the I.D. Attach a lifting device to the lifting eye of the tool, and carefully lift the assembly. Take care not to damage the stator end turns. Slip a sleeve over the stator leads, or tape them together to protect them during installation.

NOTE

Stator installation involves application of heat to the upper and middle motor housings. This must be done quickly to promote efficient installation, allowing the stator to slide into the motor housings before the housings cool.

Heat the motor housings with a torch to expand them enough for the stator to be installed; when heating the housings, **make sure** that the stator is clear to avoid a fire hazard, or damage to the windings. Apply heat evenly to the outside of the housings; excessive heat is not required.

When the motor housings are sufficiently heated, position the stator so that the leads are in line with the terminal opening, and carefully lower the stator into the motor housings until fully seated against the upper motor housing shoulder. Be careful not to damage the stator lead insulation during reassembly. If the stator "cocks" in the motor housing, remove it and try again.

After the stator is fully and squarely seated on the upper motor housing shoulder, remove the expandable disc tool and untape or remove the protective sleeve from the stator leads. Lock the stator in place by torquing the setscrews (15 and 23) to 7.5 ft. lbs. (90 in. lbs. or 1 m. kg.). Apply 'Loctite Pipe Sealant With Teflon No. 592' or equivalent on the threads of the pipe plugs (14 and 22), and install them in the motor housings.

Cover the motor housing with a clean, lint-free cloth while the rotor is being assembled.

Shaft And Rotor Installation

(Figure 1)

Inspect the rotor shaft for damaged threads, scoring in the seal area, and a nicked or damaged keyway. If the bearings were removed, inspect the bearing areas for scoring or galling. Remove nicks and burrs with a fine file or emery cloth. Inspect the rotor area for separated laminations. If the shaft is bent or damaged, or if the laminations are separated, replace the shaft and rotor (a single assembly).

If the snap ring (17) was removed, install it in the groove in the rotor shaft.



TO PREVENT DAMAGE DURING REMOVAL FROM THE SHAFT, IT IS RECOMMENDED THAT BEARINGS BE CLEANED AND INSPECTED IN PLACE. IT IS STRONGLY RECOMMENDED THAT THE BEARINGS BE REPLACED ANY TIME THE SHAFT AND ROTOR ASSEMBLY IS REMOVED.

The bearings may be heated to ease installation. An induction heater, hot oil bath, electric oven, or hot plate may be used to heat the bearings. Bearings should **never** be heated with a direct flame or directly on a hot plate.

NOTE

If a hot oil bath is used to heat the bearings, both the oil and the container must be absolutely clean. If the oil has been previously used, it must be thoroughly filtered.

Heat the bearings to a uniform temperature no higher than 250°F (120°C), and slide the bearings onto the shaft, one at a time, until they are fully seated. This should be done quickly, in one continuous motion, to prevent the bearings from cooling and sticking on the shaft.

NOTE

Position the lower bearing (16) on the shaft with the bearing manufacturer's part number (located on the O.D. of the bearing) readable (not upside-down). The part number should be closer to one edge of the

bearing than the other. This is the side of the bearing that should be toward the rotor.



USE CAUTION WHEN HANDLING HOT BEARINGS TO PREVENT BURNS.

After the bearings have been installed and allowed to cool, check to ensure that they have not moved away from the shaft shoulders in shrinking. If movement has occurred, use a suitable sized sleeve and a press to reposition the bearings against the shaft shoulders.

If heating the bearings is not practical, use a suitable sized sleeve, and an arbor (or hydraulic) press to install the bearings on the shaft.



WHEN INSTALLING THE BEARINGS ONTO THE SHAFT, NEVER PRESS OR HIT AGAINST THE OUTER RACE, BALLS, OR BALL CAGE. PRESS ONLY ON THE INNER RACE.

Install the O-ring (13) on the lower motor housing, and slide the housing over the lower bearing until the bearing seats squarely in the housing bore. Secure the lower motor housing with the retaining ring (18).

Use **fresh** solvent to clean the bearing seating bore of the upper motor housing (24). Lower the assembled housing, rotor shaft, and bearings into the middle and upper motor housings until the upper bearing seats squarely in the bearing bore.

Tap the lower motor housing with a soft-faced mallet until fully seated in the middle motor housing. Be **careful** not to cut the O-ring (13).

Coat the threads of the studs (48) with 'Never-Seez' or equivalent compound. Install the hardware (49 and 50), and torque the nuts to 20 ft. lbs. (240 in. lbs. or 2,8 m. kg.).

Apply a light coating of oil to the O-ring (26), and install it on the upper motor housing. Slide the pump casing (20) over the assembled motor until it seats against the O-ring and upper motor housing shoulder.

Refer to **PUMP END REASSEMBLY**, and reassemble the pump end components.

Terminal Housing And Power Cable Reassembly And Installation

(Figure 2)



THE ELECTRICAL POWER USED TO OPERATE THIS PUMP IS HIGH ENOUGH TO CAUSE INJURY OR DEATH. MAKE CERTAIN THAT THE CONTROL HANDLE ON THE CONTROL BOX IS IN THE OFF POSITION AND LOCKED OUT, OR THAT THE POWER SUPPLY TO THE CONTROL BOX HAS BEEN OTHERWISE CUT OFF AND LOCKED OUT, BEFORE ATTEMPTING TO OPEN OR SERVICE THE PUMP ASSEMBLY. TAG ELECTRICAL CIRCUITS TO PREVENT ACCIDENTAL STARTUP. OBTAIN THE SERVICES OF A QUALIFIED ELECTRICIAN, AND REFER TO THE WIRING DIAGRAM(S) IN **INSTALLATION, SECTION B**, TO MAKE ELECTRICAL CONNECTIONS.

Clean the exterior of the power cable with warm water and mild detergent, and check for obvious physical damage. Check the cable for continuity and insulation resistance (see **Electrical Testing in TROUBLESHOOTING**). Do not attempt repairs except to cut off either end of the cable; **splicing is not recommended**. Reinstall any wire tags or terminals which may have been removed.



NEVER ATTEMPT TO ALTER THE LENGTH OR REPAIR ANY POWER CABLE WITH A SPLICE. THE PUMP MOTOR AND CABLE MUST BE COMPLETELY WATERPROOF. INJURY OR DEATH MAY RESULT FROM ALTERATIONS.

Use oil to lightly lubricate the outside of the pump power cable (2), the rubber gland bushing (8), and the bores of the terminal gland (1) and cable grip (4) for ease of assembly. Slide the terminal gland onto the power cable. Compress the wire mesh on the cable grip, and slide it onto the cable, allowing ap-

proximately 1 ft. of cable to extend beyond the mesh. Slide the rubber cable grip bushing and washer (9) onto the cable. Temporarily tape the ground wires (green and yellow) to the cable.

When shipped from the factory, the cable leads and terminal collars (14 and 26) were encapsulated in heat-shrink tubing (12 and 29), and bonded to the terminal plate (24) with hot-melt adhesive to provide a water-tight seal. Refer to the parts list for part numbers.



DO NOT ATTEMPT TO OPERATE THIS PUMP UNLESS THE POWER CABLE LEADS ARE PROPERLY SEALED IN THE TERMINAL HOUSING. MOISTURE ENTERING THE TERMINAL HOUSING COULD CAUSE A SHORT CIRCUIT, RESULTING IN PUMP DAMAGE AND POSSIBLE SERIOUS INJURY OR DEATH TO PERSONNEL.

Sealing Terminal Housing Connections

(Figure 2)

NOTE

*Use **only** materials and heating equipment approved by Gorman-Rupp for field repairs.*

Remove all the old tubing material from the terminal collars (14 and 26), terminal posts (17 and 19), and terminal plate (24). Inspect all parts for damage, and replace as required. Use a medium-grit sandpaper to prepare the upper surface of the terminal plate in the area to be sealed.

NOTE

Clean the cable leads and terminal plate in the areas to be resealed with cleaning solvent. Incomplete sealing will occur if the surfaces are oil or grease coated.

Assemble the terminal posts, dyna seal washers, and terminal collars to the terminal plate as shown in Figure 2.

Slide the upper terminal plate gasket up over the power cable leads.

Slide a length of heat-shrink tubing up over each of the power cable leads. Insert the standard power cable leads into the large terminal collars (26), and secure them with the setscrews (27). Insert the two

control leads into the small terminal collars (14) and secure them with the setscrews (13). See Figure 4 for wiring connections.

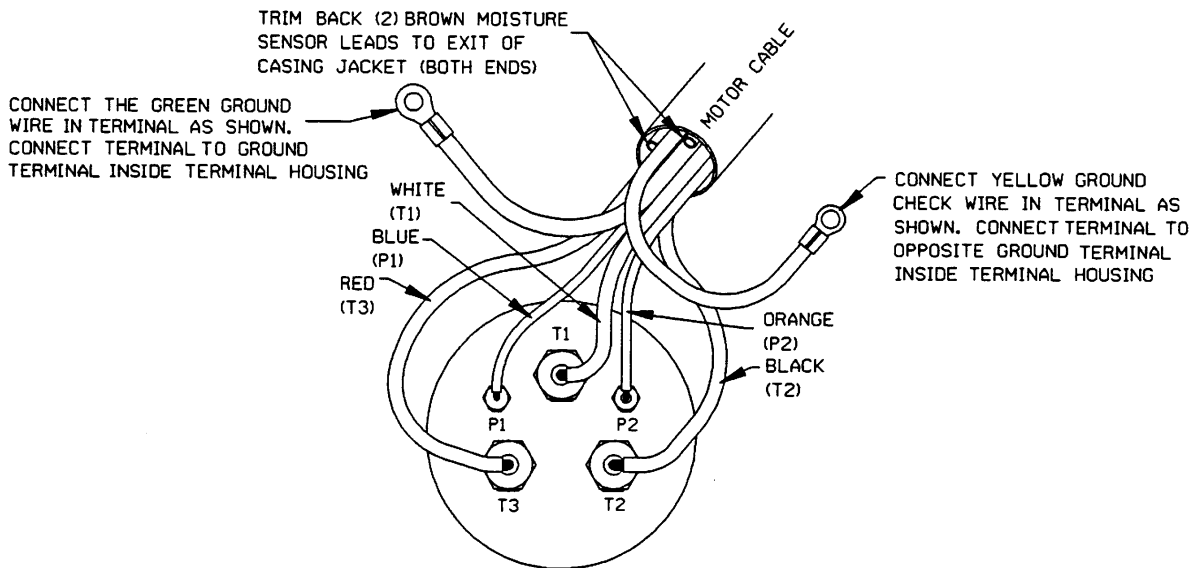

Figure 4. Terminal Housing Wiring Connections

Slide the heat-shrink tubes down over the collars until they contact the terminal plate. Carefully heat each tube with a torch or commercial hot air gun capable of producing 750°F (399°C), and shrink it around the cable leads, terminal posts, and collars.

After the tubing has shrunk and set, use a hot-melt adhesive tool (Terlan model TM-80, or equivalent) set at 450°F (232°C) to apply the adhesive (G-R part number 18661-044) around the power cable leads. The terminal collars and power cable leads must be **totally sealed** against moisture. Allow the adhesive to cool before securing the terminal housing to the motor housing.

Terminal Housing Reassembly

(Figure 2)

After the heat-shrink tubing has been installed, untape the ground leads, and slide the upper terminal plate gasket (25) and terminal housing (10) down the cable. If removed, connect the green ground lead to the ground terminal (30), and connect the yellow ground check lead to the ground check terminal (11).

Secure the terminals to the terminal housing with the hardware (31 and 32); **be sure** the terminals make good contact with the housing.

Pull gently on the power cable to remove any excess length from within the terminal housing. The terminal plate should fit loosely against the terminal housing.

Slide the terminal washer (9) down the cable and into the upper bore of the terminal housing. Oil the bore and cable, and slide the gland bushing (8) into place. Compress the wire mesh of the cable grip (4), and slide it down the cable, making sure it contacts the bushing. Slide the terminal gland (1) into place, and engage the hardware (6 and 7) finger tight. Do not fully tighten the nuts at this time.

Install the terminal housing O-ring (28) on the terminal housing. Position the lower gasket (23) against the terminal plate, then attach the motor leads to the terminal posts (17 and 19) using the setscrews (18 and 20).

NOTE

A small amount of gasket adhesive may be used to hold the upper and lower terminal plate gaskets in place to ease assembly.

If required, rotate the terminal housing and twist the motor leads to remove excess slack. Coat the

threads of the terminal housing studs (39, Figure 1) with 'Never-Seez' or equivalent, and secure the terminal housing assembly to the motor housing with the hardware (40 and 41, Figure 1); torque the nuts to 20 ft. lbs. (240 in. lbs. or 2,8 m. kg.).

Tighten the hardware (6 and 7), drawing the terminal gland down into the terminal bore. Do not overtighten and damage the terminal gland or hardware.

See **FINAL ASSEMBLY** and **LUBRICATION**.

FINAL ASSEMBLY

(Figure 1)

If the discharge flange (35) was removed from the motor housing, replace the discharge flange gasket (36). Apply 'Never-Seez' or equivalent compound on the flange studs, and secure the flange with the nuts (34).

Connect the discharge hose, and reposition the pump. If rigid piping or long hose is used, reposition the pump then connect the piping.

LUBRICATION

Seal Cavity

Check the oil level in the seal cavity before initial startup, after the first two weeks of operation, and every month thereafter.



CHECK THE OIL LEVEL ONLY WHEN THE PUMP IS COOL. IF THE OIL LEVEL PLUG IS REMOVED WHEN THE PUMP IS HOT, PRESSURE IN THE SEAL CAVITY CAN CAUSE HOT OIL TO BE EJECTED AS THE PLUG IS REMOVED.

To check the seal cavity oil, lay the pump on its side with the level plug up. Remove the plug, and screw a short 1/4 inch NPT nipple into the hole. Plug the open end of the nipple with your finger. Tip the pump upright, drain off a small amount of oil into a transparent cup, and lay the pump on its side again. If the oil level is abnormally low, or the color milky or dark, refer to **Draining Oil From Seal Cavity** in this section for instructions and troubleshooting tips. If the oil is clear, remove the nipple and top off the seal cavity with oil. Apply 'Loctite Pipe Sealant With Teflon No. 592.' or equivalent to the threads of the pipe plug, before reinstalling the plug.

When lubricating a dry (overhauled) pump, add approximately 30 ounces (0,9 liter) of lubricant (see Table 1 for lubricant specifications).

The grade of lubricant used is critical to the operation of this pump. Use premium quality submersible pump oil as specified in the following table. Oil must be stored in a clean, tightly closed container in a reasonably dry environment.

Table 1. Pump Oil Specifications

Specifications:	
Type	Premium high viscosity index, anti-wear hydraulic oil
Viscosity @ 100°F (38°C)	110 to 155
Viscosity @ 210°F (99°C)	40 to 50
Dielectric	26,000 (volts-min)
Recommended supplier:	
Gulf Oil Company	Gulf Harmony HVI AW 26
Acceptable alternate suppliers:	
Gulf Oil Company	Gulf Harmony 32 AW
Texas Oil Company	Rando HD 32 or HD AZ 32
Sun Oil Company	Sunvis 816 or 916
SOHIO (Also Boron & British Petroleum Oil Companies)	Energol-HLP 32
Shell Oil Company	Tellus 32, Tellus T-23 or T32
ARCO	Duro 32
Exxon	Nuto H 32

Motor Housing Cavity

The motor is cooled by the constant flow of the liquid being discharged through internal passages sur-

rounding the motor housing. The rotor shaft bearings are permanently sealed, and no additional lubrication is required.

**For U.S. and International Warranty Information,
Please Visit www.grpumps.com/warranty
or call:
U.S.: 419-755-1280
International: +1-419-755-1352**

**For Canadian Warranty Information,
Please Visit www.grcanada.com/warranty
or call:
519-631-2870**