

**INSTALLATION, OPERATION,
AND MAINTENANCE MANUAL**
WITH PARTS LIST



VGH SERIES PUMP

MODEL
VGH3C31-B

GORMAN-RUPP PUMPS

www.grpumps.com

Register your new
Gorman-Rupp pump online at
www.grpumps.com

Valid serial number and e-mail address required.

RECORD YOUR PUMP MODEL AND SERIAL NUMBER

Please record your pump model and serial number in the spaces provided below. Your Gorman-Rupp distributor needs this information when you require parts or service.

Pump Model: _____

Serial Number: _____

TABLE OF CONTENTS

INTRODUCTION	PAGE I – 1
SAFETY - SECTION A	PAGE A – 1
INSTALLATION – SECTION B	PAGE B – 1
PREINSTALLATION INSPECTION	PAGE B – 1
POSITIONING PUMP	PAGE B – 1
Lifting	PAGE B – 1
Mounting	PAGE B – 2
SUCTION AND DISCHARGE PIPING	PAGE B – 2
Materials	PAGE B – 2
Line Configuration	PAGE B – 2
Connections to Pump	PAGE B – 2
Gauges	PAGE B – 2
SUCTION LINES	PAGE B – 2
Fittings	PAGE B – 2
Strainers	PAGE B – 2
Sealing	PAGE B – 2
Suction Lines In Sumps	PAGE B – 3
Suction Line Positioning	PAGE B – 3
DISCHARGE LINES	PAGE B – 4
Siphoning	PAGE B – 4
Valves	PAGE B – 4
LUBRICATION	PAGE B – 4
Bearings	PAGE B – 4
Seal Assembly	PAGE B – 4
ALIGNMENT	PAGE B – 4
Coupled Drives	PAGE B – 5
V-Belt Drives	PAGE B – 5
ELECTRICAL CONNECTIONS	PAGE B – 6
GROUNDING	PAGE B – 6
OPERATION – SECTION C	PAGE C – 1
PRIMING	PAGE C – 1
Hand Primers	PAGE C – 1
Exhaust Primers	PAGE C – 2
Auxiliary Ejectors	PAGE C – 2
Vacuum Pumps	PAGE C – 2
STARTING	PAGE C – 2
Rotation	PAGE C – 2
OPERATION	PAGE C – 3
Leakage	PAGE C – 3
Liquid Temperature And Overheating	PAGE C – 3
Strainer Check	PAGE C – 3
Pump Vacuum Check	PAGE C – 3
Operational Checks	PAGE C – 3
STOPPING	PAGE C – 4
Cold Weather Preservation	PAGE C – 4

TABLE OF CONTENTS
(continued)

BEARING TEMPERATURE CHECK	PAGE C – 4
LUBRICATION	PAGE C – 4
Seal Assembly	PAGE C – 4
Bearings	PAGE C – 5
Power Source	PAGE C – 5
TROUBLESHOOTING – SECTION D	PAGE D – 1
PREVENTIVE MAINTENANCE	PAGE D – 3
PUMP MAINTENANCE AND REPAIR - SECTION E	PAGE E – 1
STANDARD PERFORMANCE CURVE	PAGE E – 1
PARTS LIST:	
Pump End Assembly	PAGE E – 3
PUMP AND SEAL DISASSEMBLY AND REASSEMBLY	PAGE E – 4
Pump Casing and Impeller Removal	PAGE E – 4
Wear Ring Removal	PAGE E – 5
Seal Removal	PAGE E – 5
Shaft and Bearing Removal And Disassembly	PAGE E – 5
Shaft and Bearing Reassembly and Installation	PAGE E – 6
Wear Ring Installation	PAGE E – 7
Seal Installation	PAGE E – 7
Impeller and Pump Casing Installation	PAGE E – 9
Final Pump Assembly	PAGE E – 9
LUBRICATION	PAGE E – 9
Seal Assembly	PAGE E – 9
Bearings	PAGE E – 9

INTRODUCTION

Thank You for purchasing a Gorman-Rupp pump. **Read this manual** carefully to learn how to safely install and operate your pump. Failure to do so could result in personal injury or damage to the pump.

Because pump installations are seldom identical, this manual cannot possibly provide detailed instructions and precautions for every aspect of each specific application. Therefore, it is the responsibility of the owner/installer of the pump to ensure that applications not addressed in this manual are performed **only** after establishing that neither operator safety nor pump integrity are compromised by the installation. Pumps and related equipment **must** be installed and operated according to all national, local and industry standards.

If there are any questions regarding the pump or its application which are not covered in this manual or in other literature accompanying this unit, please contact your Gorman-Rupp distributor, or The Gorman-Rupp Company:

The Gorman-Rupp Company
P.O. Box 1217
Mansfield, Ohio 44901-1217
Phone: (419) 755-1011
 or:
Gorman-Rupp of Canada Limited
70 Burwell Road
St. Thomas, Ontario N5P 3R7
Phone: (519) 631-2870

For information or technical assistance on the power source, contact the power source manufacturer's local dealer or representative.

HAZARD AND INSTRUCTION DEFINITIONS

The following are used to alert maintenance personnel to procedures which require special attention, to those which could damage equipment, and to those which could be dangerous to personnel:



Immediate hazards which WILL result in severe personal injury or death. These instructions describe the procedure required and the injury which will result from failure to follow the procedure.



Hazards or unsafe practices which COULD result in severe personal injury or death. These instructions describe the procedure required and the injury which could result from failure to follow the procedure.



Hazards or unsafe practices which COULD result in minor personal injury or product or property damage. These instructions describe the requirements and the possible damage which could result from failure to follow the procedure.

NOTE

Instructions to aid in installation, operation, and maintenance or which clarify a procedure.

SAFETY - SECTION A

This information applies to VGH Series basic pumps. Gorman-Rupp has no control over or particular knowledge of the power source which will be used. Refer to the manual accompanying the power source before attempting to begin operation.

Because pump installations are seldom identical, this manual cannot possibly provide detailed instructions and precautions for each specific application. Therefore, it is the owner/installer's responsibility to ensure that applications not addressed in this manual are performed only after establishing that neither operator safety nor pump integrity are compromised by the installation.



Before attempting to open or service the pump:

1. Familiarize yourself with this manual.
2. Lock out or disconnect the power source to ensure that the pump will remain inoperative.
3. Allow the pump to completely cool if overheated.
4. Check the temperature before opening any covers, plates, or plugs.
5. Close the suction and discharge valves.
6. Vent the pump slowly and cautiously.
7. Drain the pump.



This pump is designed to handle clear liquids that do not contain large en-

trained solids. Only the Gorman-Rupp Company or an authorized Gorman-Rupp distributor may modify a pump or approve its use for handling volatile, flammable liquids. If the pump is used for handling volatile, flammable liquids, all drivers and/or controls must meet industry standards and codes for use in an explosive atmosphere. Do not attempt to pump liquids for which the pump, driver and/or controls have not been approved, or which may damage the pump or endanger personnel as a result of pump failure.



If this pump has been approved for use with volatile and/or flammable liquids, be certain proper safety practices are followed before operating or servicing the pump. Provide adequate ventilation, prohibit smoking, wear static-resistant clothing and shoes. Clean up all fuel spills immediately after occurrence.



Do not install and operate a non-explosion proof motor in an explosive atmosphere. Install, connect, and operate the motor in accordance with the National Electric Code and all local codes. If there is a conflict between the instructions in the manual accompanying the unit and the National Electric Code or the applicable local code, the National or local code shall take precedence.



If this pump is used with volatile and/or flammable liquids, overheating may produce dangerous fumes. Take precautions to ensure the area surrounding

the pump is adequately ventilated. Allow the pump to cool and use extreme caution when venting the pump, or when removing covers, plates, plugs, or fittings.



Death or serious personal injury and damage to the pump or components can occur if proper lifting procedures are not observed. Make certain that hoists, chains, slings or cables are in good working condition and of sufficient capacity and that they are positioned so that loads will be balanced and the pump or components will not be damaged when lifting. Suction and discharge hoses and piping must be removed from the pump before lifting. Lift the pump or component only as high as necessary and keep personnel away from suspended objects.



After the pump has been installed, make certain that the pump and all piping or hose connections are tight, properly supported and secure before operation.



Do not operate the pump without the shields and/or guards in place over the drive shaft, belts, and/or couplings, or other rotating parts. Exposed rotating parts can catch clothing, fingers, or tools, causing severe injury to personnel.



Do not operate the pump against a

closed discharge valve for long periods of time. If operated against a closed discharge valve, pump components will deteriorate, and the liquid could come to a boil, build pressure, and cause the pump casing to rupture or explode.



Overheated pumps can cause severe burns and injuries. If overheating of the pump occurs:

1. Stop the pump immediately.
2. Ventilate the area.
3. Allow the pump to completely cool.
4. Check the temperature before opening any covers, plates, gauges, or plugs.
5. Vent the pump slowly and cautiously.
6. Refer to instructions in this manual before restarting the pump.



Do not remove plates, covers, gauges, pipe plugs, or fittings from an overheated pump. Vapor pressure within the pump can cause parts being disengaged to be ejected with great force. Allow the pump to completely cool before servicing.



Never run this pump backwards. Be certain that rotation is correct before fully engaging the pump.



Pumps and related equipment must be installed and operated according to all national, local and industry standards.

INSTALLATION – SECTION B

Review all SAFETY information in Section A.

Since pump installations are seldom identical, this section offers only general recommendations and practices required to inspect, position, and arrange the pump and piping.

Most of the information pertains to a standard **static lift** application where the pump is positioned above the free level of liquid to be pumped.

If installed in a **flooded suction application** where the liquid is supplied to the pump under pressure, some of the information such as mounting, line configuration, and priming must be tailored to the specific application. Since the pressure supplied to the pump is critical to performance and safety, **be sure** to limit the incoming pressure to 50% of the maximum permissible operating pressure as shown on the pump performance curve (see Section E, Page 1).

For further assistance, contact your Gorman-Rupp distributor or the Gorman-Rupp Company.

PREINSTALLATION INSPECTION

The pump assembly was inspected and tested before shipment from the factory. Before installation, inspect the pump for damage which may have occurred during shipment. Check as follows:

- a. Inspect the pump and engine for cracks, dents, damaged threads, and other obvious damage.
- b. Check for and tighten loose attaching hardware. Since gaskets tend to shrink after drying, check for loose hardware at mating surfaces.
- c. Carefully read all tags, decals, and markings on the pump assembly, and perform all duties indicated.
- d. Check levels and lubricate as necessary. Refer to **LUBRICATION** in the **MAINTENANCE AND REPAIR** section of this manual and perform duties as instructed.
- e. If the pump has been stored for more than 12 months, some of the components or lubricants may have exceeded their maximum shelf life. These **must be inspected or replaced** to ensure maximum pump service.

If the maximum shelf life has been exceeded, or if anything appears to be abnormal, contact your Gorman-Rupp distributor or the factory to determine the repair or updating policy. **Do not** put the pump into service until appropriate action has been taken.

POSITIONING PUMP

Lifting



Death or serious personal injury and damage to the pump or components can occur if proper lifting procedures are not observed. Make certain that hoists, chains, slings or cables are in good working condition and of sufficient capacity and that they are positioned so that loads will be balanced and the pump or components will not be damaged when lifting. Suction and discharge hoses and piping must be removed from the pump before lifting. Lift the pump or component only as high as necessary and keep personnel away from suspended objects.

Pump unit weights will vary depending on the mounting and drive provided. Check the shipping tag on the unit packaging for the actual weight, and use lifting equipment with appropriate capacity. Drain the pump and remove all customer-installed equipment such as suction and discharge hoses or piping before attempting to lift existing, installed units.



The pump assembly can be seriously damaged if the cables or chains used to lift and move the unit are improperly wrapped around the pump.

Mounting

Locate the pump in an accessible place as close as practical to the liquid being pumped. Level mounting is essential for proper operation.

The pump may have to be supported or shimmed to provide for level operation or to eliminate vibration.

SUCTION AND DISCHARGE PIPING

Materials

Either pipe or hose may be used for suction and discharge lines; however, the materials must be compatible with the liquid being pumped. If hose is used in suction lines, it must be the rigid-wall, reinforced type to prevent collapse under suction. Using piping couplings in suction lines is not recommended.

Line Configuration

Keep suction and discharge lines as straight as possible to minimize friction losses. Make minimum use of elbows and fittings, which substantially increase friction loss. If elbows are necessary, use the long-radius type to minimize friction loss.

Connections to Pump

Before tightening a connecting flange, align it exactly with the pump port. Never pull a pipe line into place by tightening the flange bolts and/or couplings.

Lines near the pump must be independently supported to avoid strain on the pump which could cause excessive vibration, decreased bearing life, and increased shaft and seal wear. If hose-type lines are used, they should have adequate support

to secure them when filled with liquid and under pressure.

Gauges

Most pumps are drilled and tapped for installing discharge pressure and vacuum suction gauges. If these gauges are desired for pumps that are not tapped, drill and tap the suction and discharge lines not less than 18 inches (457,2 mm) from the suction and discharge ports and install the lines. Installation closer to the pump may result in erratic readings.

SUCTION LINES

To avoid air pockets which could affect pump priming, the suction line must be as short and direct as possible. When operation involves a suction lift, the line must always slope upward to the pump from the source of the liquid being pumped; if the line slopes down to the pump at any point along the suction run, air pockets will be created.

Fittings

Suction lines should be the same size as the pump inlet. If reducers are used in suction lines, they should be the eccentric type, and should be installed with the flat part of the reducers uppermost to avoid creating air pockets. Valves are not normally used in suction lines, but if a valve is used, install it with the stem horizontal to avoid air pockets.

Strainers

If a strainer is not furnished with the pump, but is installed by the pump user, make certain that the total area of the openings in the strainer is at least three or four times the cross section of the suction line, and that the openings will not permit passage of solids larger than the solids handling capability of the pump.

This pump is designed to handle up to 35/64 inch (14 mm) diameter spherical solids.

Sealing

Since even a slight leak will affect priming, head, and capacity, especially when operating with a

high suction lift, all connections in the suction line should be sealed with pipe dope to ensure an airtight seal. Follow the sealant manufacturer's recommendations when selecting and applying the pipe dope. The pipe dope should be compatible with the liquid being pumped.

Suction Lines In Sumps

If a single suction line is installed in a sump, it should be positioned away from the wall of the sump at a distance equal to 1 1/2 times the diameter of the suction line.

If there is a liquid flow from an open pipe into the sump, the flow should be kept away from the suction inlet because the inflow will carry air down into the sump, and air entering the suction line will reduce pump efficiency.

If it is necessary to position inflow close to the suction inlet, install a baffle between the inflow and the suction inlet at a distance 1-1/2 times the diameter of the suction pipe. The baffle will allow entrained

air to escape from the liquid before it is drawn into the suction inlet.

If two suction lines are installed in a single sump, the flow paths may interact, reducing the efficiency of one or both pumps. To avoid this, position the suction inlets so that they are separated by a distance equal to at least 3 times the diameter of the suction pipe.

Suction Line Positioning

The depth of submergence of the suction line is critical to efficient pump operation. Figure 1 shows recommended minimum submergence vs. velocity.

NOTE

The pipe submergence required may be reduced by installing a standard pipe increaser fitting at the end of the suction line. The larger opening size will reduce the inlet velocity. Calculate the required submergence using the following formula based on the increased opening size (area or diameter).

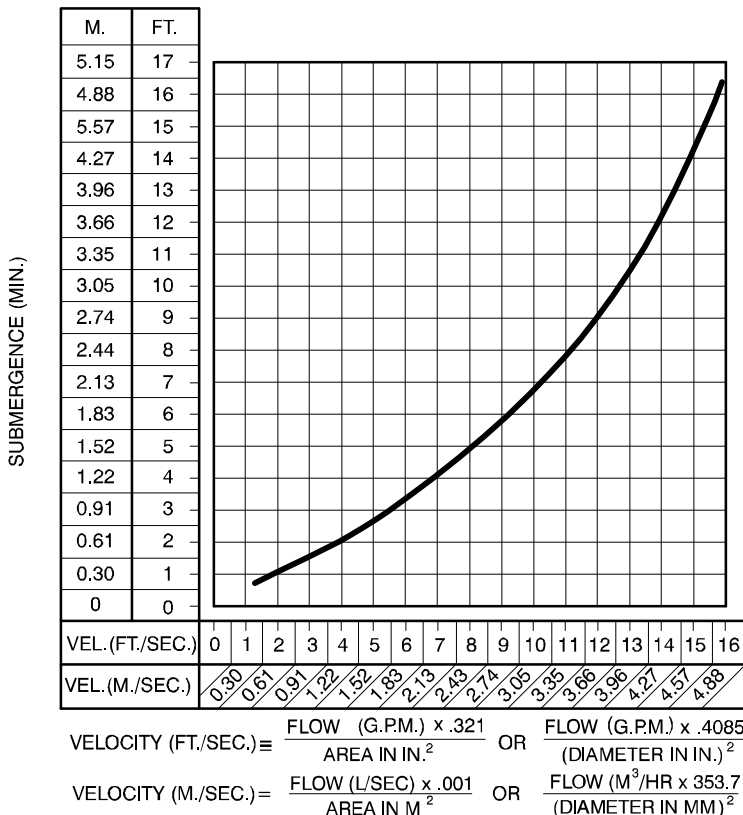

Figure 1. Recommended Minimum Suction Line Submergence vs. Velocity

DISCHARGE LINES

Siphoning

Do not terminate the discharge line at a level lower than that of the liquid being pumped unless a siphon breaker is used in the line. Otherwise, a siphoning action causing damage to the pump could result.

Valves

If a throttling valve is desired in the discharge line, use a valve as large as the largest pipe to minimize friction losses. Never install a throttling valve in a suction line.

With high discharge heads, it is recommended that a throttling valve and a system check valve be installed in the discharge line to protect the pump from excessive shock pressure and reverse rotation when it is stopped.



If the application involves a high discharge head, gradually close the discharge throttling valve before stopping the pump.

LUBRICATION

Bearings

The bearing housing was not lubricated when shipped from the factory. To lubricate the bearing cavity, fill the constant level oiler as shown in Figure 2, then close the oiler and allow the oil to drain into the bearing cavity. Repeat this procedure until oil no longer drains from the constant level oiler.

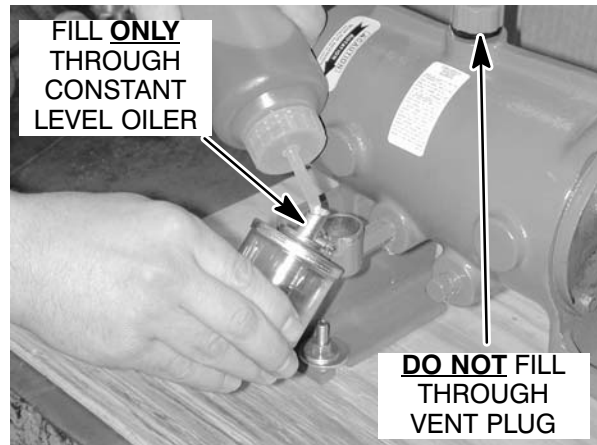

Figure 2. Lubricating Bearing Cavity

Do not fill the bearing cavity through the vent plug in the top of the housing. This will result in over-filling, and can cause leakage, excessive heat build up and/or premature bearing failure.

Check the oil level regularly through the constant level oiler and add oil as required.

Seal Assembly

The seal assembly is lubricated by the medium being pumped and no additional lubrication is required.

ALIGNMENT

The alignment of the pump and its power source is critical for trouble-free mechanical operation. In either a flexible coupling or V-belt driven system, the driver and pump must be mounted so that their shafts are aligned with and parallel to each other. It is imperative that alignment be checked after the pump and piping are installed, and before operation.

NOTE

Check Rotation, Section C, before final alignment of the pump.

When mounted at the Gorman-Rupp factory, driver and pump are aligned before shipment. Misalignment will occur in transit and handling. Pumps **must** be checked and realigned before operation. Before checking alignment, tighten the foundation bolts. The pump casing feet and/or pedestal feet, and the driver mounting bolts should also be tightly secured.



WARNING!

When checking alignment, disconnect the power source to ensure that the pump will remain inoperative.



CAUTION

Adjusting the alignment in one direction may alter the alignment in another direction. Check each procedure after altering alignment.

Coupled Drives

When using couplings, the axis of the power source must be aligned to the axis of the pump shaft in both the horizontal and vertical planes. Most couplings require a specific gap or clearance between the driving and the driven shafts. Refer to the coupling manufacturer's service literature.

Align spider insert type couplings by using calipers to measure the dimensions on the circumference of the outer ends of the coupling hub every 90°. The coupling is in alignment when the hub ends are the same distance apart at all points (see Figure 3A).

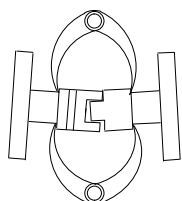

Figure 3A. Aligning Spider-Type Couplings

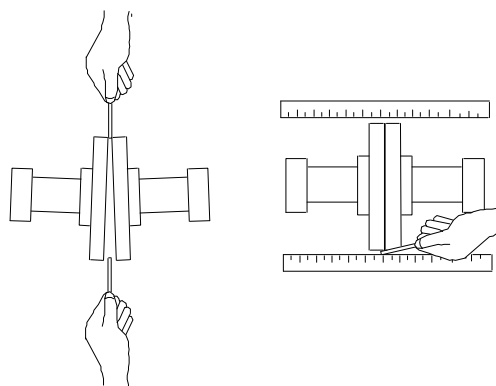

Figure 3B. Aligning Non-Spider Type Couplings

Align non-spider type couplings by using a feeler gauge or taper gauge between the coupling halves every 90°. The coupling is in alignment when the hubs are the same distance apart at all points (see Figure 3B).

Check parallel adjustment by laying a straightedge across both coupling rims at the top, bottom, and side. When the straightedge rests evenly on both halves of the coupling, the coupling is in horizontal parallel alignment. If the coupling is misaligned, use a feeler gauge between the coupling and the straightedge to measure the amount of misalignment.

V-Belt Drives

When using V-belt drives, the power source and the pump must be parallel. Use a straightedge along the sides of the pulleys to ensure that the pulleys are properly aligned (see Figure 3C). In drive systems using two or more belts, make certain that the belts are a matched set; unmatched sets will cause accelerated belt wear.

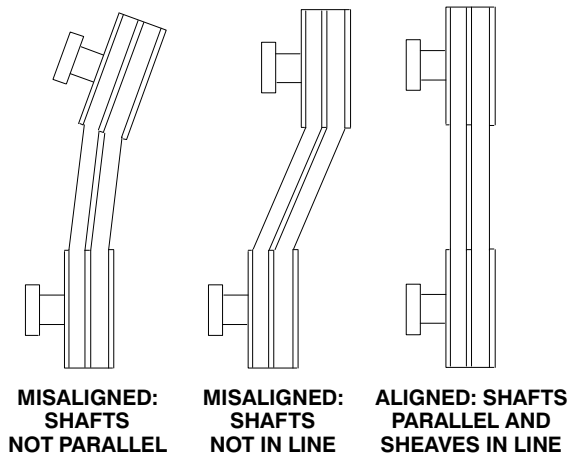

Figure 3C. Alignment of V-Belt Driven Pumps

Tighten the belts in accordance with the belt manufacturer’s instructions. If the belts are too loose, they will slip; if the belts are too tight, there will be excessive power loss and possible bearing failure. Select pulleys that will match the proper speed ratio; overspeeding the pump may damage both pump and power source.



Do not operate the pump without the guard in place over the rotating parts. exposed rotating parts can catch clothing, fingers, or tools, causing severe injury to personnel.

ELECTRICAL CONNECTIONS

If the pump is driven by an electric motor, check that the electrical service available matches the motor requirements stamped on the motor nameplate before connecting a motor to the incoming power. Check that the motor speed meets pump specifications.

If rotation is incorrect on a three-phase motor, have a qualified electrician interchange any two of the three phase wires to change direction. If rotation is incorrect on a single-phase motor, consult the literature supplied with the motor for specific instructions.



The electrical power used to operate the pump is high enough to cause injury or death. Obtain the services of a qualified electrician to make all electrical connections.



If the pump is powered by an electric motor, do not operate a non-explosion proof motor in an explosive atmosphere. An explosion, which may cause severe personal injury or death, could result. Install, connect and operate the motor in accordance with the National Electric Code and all local codes. If there is a conflict between the instructions in the manual accompanying the unit and the National Electric Code or applicable local code, the National or Local code shall take precedence. All electrical equipment supplied with the pump conforms to applicable federal regulations and national codes in effect on the date of manufacture.

GROUNDING

If the pump has been approved to pump volatile or flammable liquids, the unit must be grounded by attaching the ground wire assembly to a ground rod in order to eliminate electrostatic build-up by the liquid being pumped. Install the ground rod in accordance with the National Electrical Codes and all local codes. Be sure the fastening device makes a tight electrical connection with the rod and the pump.

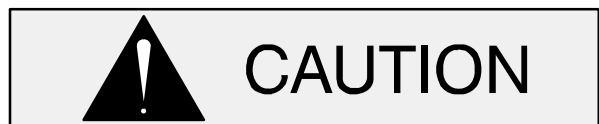

Inspect and test the ground wire assembly for conductivity. replace broken or frayed wire before resuming operation.

OPERATION – SECTION C

Review all SAFETY information in Section A.

Follow the instructions on all tags, labels and decals attached to the pump.



This pump is designed to handle most non-volatile, non-flammable liquids containing specified entrained solids. Only the Gorman-Rupp Company or an authorized Gorman-Rupp distributor may modify a pump or approve its use for handling volatile, flammable liquids. If the pump is used for handling volatile, flammable liquids, all drivers and/or controls must meet industry standards and codes for use in an explosive atmosphere. Do not attempt to pump liquids for which the pump, driver and/or controls have not been approved, or which may damage the pump or endanger personnel as a result of pump failure.



If this pump has been approved for use with volatile and/or flammable liquids, be certain proper safety practices are followed before operating or servicing the pump. Provide adequate ventilation, prohibit smoking, wear static-resistant clothing and shoes. Clean up all fuel spills immediately after occurrence.



Pump speed and operating conditions must be within the performance range shown on the curve in Parts Lists manual.

PRIMING

Install the pump and piping as described in **INSTALLATION**. Make sure that the piping connections are tight, and that the pump is securely mounted. Check that the pump is properly lubricated (see **LUBRICATION** in the **MAINTENANCE AND REPAIR** manual).

This is not a self-priming pump, so an external priming device must be used if the pump is installed on a **suction lift**. A foot valve may be installed at the end of the suction pipe to maintain the prime; however, this may adversely affect pump performance due to friction loss. Many standard centrifugal models are equipped with a hand-operated vacuum pump, exhaust primer, or ejector for this purpose. If a priming device was not furnished with the pump, it may be ordered from the factory as an option.

Before attempting to operate the priming device, close the discharge throttling valve. (Installation of a spring-loaded check valve is also recommended to facilitate priming.) Once the pump is fully primed, close the valve between the priming device and pump to preserve the prime.

Start the pump and open the discharge valve slowly to fill the discharge line. When installed in a **flooded suction** application, simply open the system valves and permit the incoming liquid to evacuate the air. After the pump and piping system have completely filled, evacuate any remaining air pockets in the pump or suction line.



Never operate the pump unless there is liquid in the pump casing. The pump will not prime when dry. Extended operation of a dry pump will destroy the seal assembly.

Hand Primers

Hand-operated primers are usually mounted on the pump and, when operated, draw air out of the

suction line and pump casing. To prime a pump with a hand vacuum pump, open the cock on the pump priming line. Operate the hand pump until liquid flows out of the check valve on the bottom of the primer pump. Once the pump is primed, close the valve located between the primer and the pump so that the prime will not be lost.

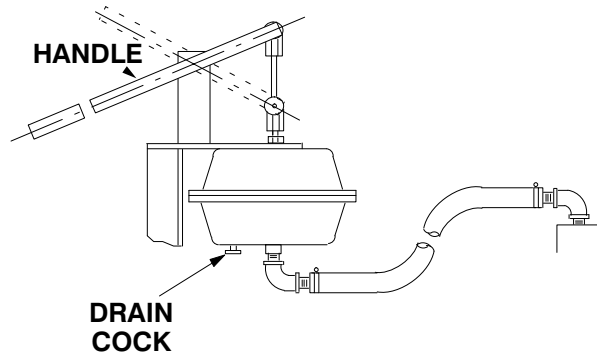

Figure 1. Hand Primer Assembly

Exhaust Primers

Engine driven pumps normally take advantage of the engine exhaust gases by using them to operate an exhaust primer. The exhaust is directed through a venturi which creates a vacuum in the pump casing in order to fill the suction line and pump casing with liquid. To prime a pump using an exhaust primer, open the gas cock in the priming line and engage the exhaust primer until liquid is thrown out of the ejector nozzle.

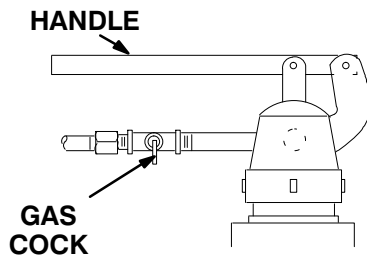

Figure 2. Exhaust Primer Assembly

Air can be exhausted to prime a pump by using a vacuum pump. Either a wet type or a dry type vacuum pump may be used; however, a wet type is preferred since it will not be damaged if liquid enters it. If a dry vacuum pump is used, provisions must be made to keep liquid from entering it.

Auxiliary Ejectors

Ejectors function much like exhaust primers. They may be operated by steam, compressed air, water or exhaust gases. To prime a pump using an ejector, open the gas cock in the priming line and operate the ejector until liquid is thrown out the ejector nozzle.

Vacuum Pumps

Air can be exhausted to prime a pump by using a vacuum pump. Either a wet type or a dry type vacuum pump may be used; however, a wet type is preferred since it will not be damaged if liquid enters it. If a dry vacuum pump is used, provisions must be made to keep liquid from entering it.

STARTING

Starting procedures will vary slightly depending on the pump application, type of priming device, and type of drive. Consult the operations manual furnished with the power source.

Rotation

The correct direction of pump rotation is indicated by an arrow on the pump body or accompanying decals. If the pump is operated in the wrong direction, the impeller could become loosened from the shaft and seriously damage the pump.



The pump must operate in the direction indicated by the arrow on the pump, or accompanying decals. Reverse rotation could loosen the impeller and seriously damage the pump.

If the pump is driven by an electric motor, consult the operating manual furnished with the motor before attempting to start the motor.

If rotation is incorrect on a three-phase motor, have a qualified electrician interchange any two of the three phase wires to change direction. If rotation is incorrect on a single-phase motor, consult the literature supplied with the motor for specific instructions.

OPERATION

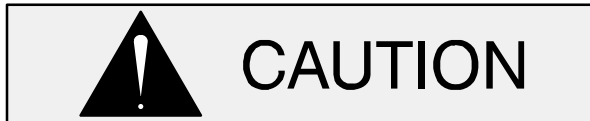

Pump speed and operating points must be within the continuous performance range shown on the pump curve (see page E–1).

Leakage

No leakage should be visible at pump mating surfaces, or at pump connections or fittings. Keep all line connections and fittings tight to maintain maximum pump efficiency.

Liquid Temperature And Overheating

Refer to the Specification Data sheet for the **maximum** liquid temperature for your specific pump. Do not apply the pump at a higher operating temperature.

Overheating can occur if operated with the valves in the suction or discharge lines closed. Operating against closed valves could bring the liquid to a boil, build pressure, and cause the pump to rupture or explode. If overheating occurs, stop the pump and allow it to cool before servicing it. Refill the pump casing with cool liquid.



Allow an over-heated pump to completely cool before servicing. Do not remove plates, covers, gauges, or fittings from an over-heated pump. Liquid within the pump can reach boiling temperatures, and vapor pressure within the pump can cause parts being disengaged to be ejected with great force. After the pump cools, drain the liquid from the pump by removing the casing drain plug. Use caution when removing the plug to prevent injury to personnel from hot liquid.

If overheating does occur, stop the pump immediately and allow it to cool before servicing it. **Approach any overheated pump cautiously.**

Strainer Check

If a suction strainer has been shipped with the pump or installed by the user, check the strainer regularly, and clean it as necessary. The strainer should also be checked if pump flow rate begins to drop. If a vacuum suction gauge has been installed, monitor and record the readings regularly to detect strainer blockage.

Never introduce air or steam pressure into the pump casing or piping to remove a blockage. This could result in personal injury or damage to the equipment. If backflushing is absolutely necessary, liquid pressure **must** be limited to 50% of the maximum permissible operating pressure shown on the pump performance curve.

Pump Vacuum Check

With the pump inoperative, install a vacuum gauge in the system, using pipe dope on the threads. Block the suction line and start the pump. At operating speed the pump should pull a vacuum of 20 inches (508 mm) or more of mercury. If it does not, check for air leaks in the seal, gasket, or discharge valve.

Open the suction line, and read the vacuum gauge with the pump primed and at operation speed. Shut off the pump. The vacuum gauge reading will immediately drop proportionate to static suction lift, and should then stabilize. If the vacuum reading falls off rapidly after stabilization, an air leak exists. Before checking for the source of the leak, check the point of installation of the vacuum gauge.

Operational Checks

Check the pump for proper operation when it is first started and periodically thereafter to identify minor problems.

Check the pump for unusual noises or excessive vibration while it is operating. If noise or vibration is excessive, stop the pump and refer to **TROUBLESHOOTING**, Section D, for possible causes.



To avoid serious damage to the pump, check for unusual noises or excessive vibration while the pump is running. If noise or vibration is excessive, stop operation and refer to the **TROUBLESHOOTING**, Section D, before resuming operation.

STOPPING

Never halt the flow of liquid suddenly. If the liquid being pumped is stopped abruptly, damaging shock waves can be transmitted to the pump and piping system. Close all connecting valves slowly.

On engine driven pumps, reduce the throttle speed slowly and allow the engine to idle briefly before stopping.



If the application involves a high discharge head, gradually close the discharge throttling valve before stopping the pump.

After stopping the pump, lock out or disconnect the power source to ensure that the pump will remain inoperative.

Cold Weather Preservation

In below freezing conditions, drain the pump to prevent damage from freezing. Also, clean out any solids by flushing with a hose. Operate the pump for approximately one minute; this will remove any remaining liquid that could freeze the pump rotating parts. If the pump will be idle for more than a few hours, or if it has been pumping liquids containing a large amount of solids, drain the pump, and flush it thoroughly with clean water. To prevent large solids from clogging the drain port and preventing the pump from completely draining, insert a rod or stiff wire in the drain port, and agitate the liquid during the draining process. Clean out any remaining solids by flushing with a hose.

BEARING TEMPERATURE CHECK

Bearings normally run at higher than ambient temperatures because of heat generated by friction. Temperatures up to 160°F (71° C) are considered normal for bearings, and they can operate safely to at least 180°F (82° C).

Checking bearing temperatures by hand is inaccurate. Bearing temperatures can be measured accurately by placing a contact-type thermometer against the housing. Record this temperature for future reference.

A sudden increase in bearing temperature is a warning that the bearings are at the point of failing to operate properly. Make certain that the bearing lubricant is of the proper viscosity and at the correct level (see **LUBRICATION** in the **Maintenance And Repair** manual). Bearing overheating can also be caused by shaft misalignment and/or excessive vibration.

When pumps are first started, the bearings may seem to run at temperatures above normal. Continued operation should bring the temperatures down to normal levels.

LUBRICATION



Do not remove plates, covers, gauges, pipe plugs or fittings from an overheated pump. Vapor pressure within the pump can cause parts being disengaged to be ejected with great force. Allow the pump to completely cool before servicing.

On a new pump, check the oil level in the bearing cavity before initial startup, after the first two weeks of operation, and every month thereafter.

Before installing or removing a lubrication plug, always clean the area around the plug to prevent contamination.

Seal Assembly

The self lubricated seal assembly is lubricated by the medium being pumped, or by a flow of fresh liq-

uid from an external source. When handling clean liquids, flushing liquid is taken from the pump discharge and supplied through the seal flush line supplied with the pump.

When handling abrasive or tacky liquids, it may be necessary to supply fresh lubricating liquid from an external source. Be sure the liquid supplied to the seal is compatible with the liquid being pumped, and that its flow is controlled to prevent dilution. Consult the factory if flushing is required.

Bearings

The bearing housing was not lubricated when shipped from the factory. See **INSTALLATION**, Section B, and lubricate the bearing housing as indicated. Check the constant level oiler regularly and keep it full of oil. When lubrication is required, flip the transparent constant level oiler cup open and fill it with SAE No. 30 non-detergent oil.

Under normal conditions, drain the bearing housing once each year and refill with clean oil. Change

the oil more frequently if the pump is operated continuously or installed in an environment with rapid temperature change.

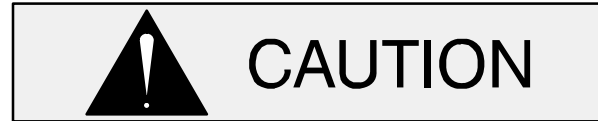

Monitor the condition of the bearing lubricant regularly for evidence of rust or moisture condensation. This is especially important in areas where variable hot and cold temperatures are common.

For cold weather operation, consult the factory or a lubricant supplier for the recommended grade of oil.

Power Source

Consult the literature supplied with the power source, or contact your local power source representative.

TROUBLESHOOTING – SECTION B

Review all SAFETY information in Section A.



Before attempting to open or service the pump:

- 1. Familiarize yourself with this manual.**
- 2. Lock out or disconnect the power source and take the necessary precautions to ensure that the pump will remain inoperative.**
- 3. Allow the pump to completely cool if overheated.**
- 4. Check the temperature before opening any covers, plates, or plugs.**
- 5. Close the suction and discharge valves.**
- 6. Vent the pump slowly and cautiously.**
- 7. Drain the pump.**

Table D-1 Troubleshooting Chart

TROUBLE	POSSIBLE CAUSE	PROBABLE REMEDY
PUMP FAILS TO PRIME	Auxiliary priming device faulty or improperly installed. Discharge check valve open. Air leak in suction line. Lining of suction hose collapsed. Leaking or worn seal or pump gasket. Strainer clogged.	Repair priming device or check installation. Check position of handle; close valve. Correct leak. Replace suction hose. Check pump vacuum. Replace leaking or worn seal or gasket. Check strainer and clean if necessary.
PUMP STOPS OR FAILS TO DELIVER RATED FLOW OR PRESSURE	Air leak in suction line. Lining of suction hose collapsed. Suction intake not submerged at proper level or sump too small. Strainer clogged.	Correct leak. Replace suction hose. Check installation and correct submergence as needed. Check strainer and clean if necessary.

Table D-1 Troubleshooting Chart (Continued)

TROUBLE	POSSIBLE CAUSE	PROBABLE REMEDY
PUMP STOPS OR FAILS TO DELIVER RATED FLOW OR PRESSURE (cont.)	Impeller or other wearing parts worn or damaged.	Replace worn or damaged parts. Check that impeller is properly centered and rotates freely.
	Leaking or worn seal or pump gasket.	Check pump vacuum. Replace leaking or worn seal or gasket.
	Impeller clogged.	Free impeller of debris.
	Pump running backwards (electric motor driven models).	Check direction of rotation. Correct 3-phase wiring by interchanging any two motor leads at control box. (See Pump Rotation in the Installation and Operations Manual.)
	Suction lift or discharge head too high.	Check piping installation and install bypass line if needed. See INSTALLATION in the Installation and Operations manual.
	Liquid solution too thick.	Dilute if possible.
PUMP REQUIRES TOO MUCH POWER	Pump speed too high.	Check governor setting (engine driven models).
	Discharge head too low.	Adjust discharge valve.
	Liquid solution too thick.	Dilute if possible.
	Impeller jammed due to debris or insufficient clearance.	Disassemble pump and check impeller.
PUMP CLOGS FREQUENTLY	Discharge flow too slow.	Open discharge valve fully to increase flow rate, and run power source at maximum governed speed.
	Suction check valve or foot valve clogged or binding.	Clean valve.
EXCESSIVE NOISE	Cavitation in pump.	Reduce suction lift and/or friction losses in suction line. Record vacuum and pressure gauge readings and consult local representative or factory.
	Pumping entrained air.	Locate and eliminate source of air bubble.
	Pump or drive not securely mounted.	Secure mounting hardware.
	Impeller clogged or damaged.	Clean out debris; replace damaged parts.

Table D-1 Troubleshooting Chart (Continued)

TROUBLE	POSSIBLE CAUSE	PROBABLE REMEDY
BEARINGS RUN TOO HOT	Bearing temperature is high, but within limits.	Check bearing temperature regularly to monitor any increase
	Low or incorrect lubricant.	Check for proper type and level of lubricant.

PREVENTIVE MAINTENANCE

Since pump applications are seldom identical, and pump wear is directly affected by such things as the abrasive qualities, pressure and temperature of the liquid being pumped, this section is intended only to provide general recommendations and practices for preventive maintenance. Regardless of the application however, following a routine preventive maintenance schedule will help assure trouble-free performance and long life from your Gorman-Rupp pump. For specific questions concerning your application, contact your Gorman-Rupp distributor or the Gorman-Rupp Company.

Record keeping is an essential component of a good preventive maintenance program. Changes in suction and discharge gauge readings (if so

equipped) between regularly scheduled inspections can indicate problems that can be corrected before system damage or catastrophic failure occurs. The appearance of wearing parts should also be documented at each inspection for comparison as well. Also, if records indicate that a certain part (such as the seal) fails at approximately the same duty cycle, the part can be checked and replaced before failure occurs, reducing unscheduled down time.

For new applications, a first inspection of wearing parts at 250 hours will give insight into the wear rate for your particular application. Subsequent inspections should be performed at the intervals shown on the chart below. Critical applications should be inspected more frequently.

Preventive Maintenance Schedule					
Item	Service Interval*				
	Daily	Weekly	Monthly	Semi-Annually	Annually
General Condition (Temperature, Unusual Noises or Vibrations, Cracks, Leaks, Loose Hardware, Etc.)	I				
Pump Performance (Gauges, Speed, Flow)	I				
Bearing Lubrication		I			R
Seal Lubrication (And Packing Adjustment, If So Equipped)		I			R
V-Belts (If So Equipped)			I		
Air Release Valve Plunger Rod (If So Equipped)			I	C	
Front Impeller Clearance (Wear Plate)				I	
Rear Impeller Clearance (Seal Plate)				I	
Check Valve					I
Pressure Relief Valve (If So Equipped)					C
Pump and Driver Alignment					I
Shaft Deflection					I
Bearings					I
Bearing Housing					I
Piping					I
Driver Lubrication – See Mfgr’s Literature					I
<p>Legend: I = Inspect, Clean, Adjust, Repair or Replace as Necessary C = Clean R = Replace</p> <p>* Service interval based on an intermittent duty cycle equal to approximately 4000 hours annually. Adjust schedule as required for lower or higher duty cycles or extreme operating conditions.</p>					

PUMP MAINTENANCE AND REPAIR - SECTION E

MAINTENANCE AND REPAIR OF THE WEARING PARTS OF THE PUMP WILL MAINTAIN PEAK OPERATING PERFORMANCE.

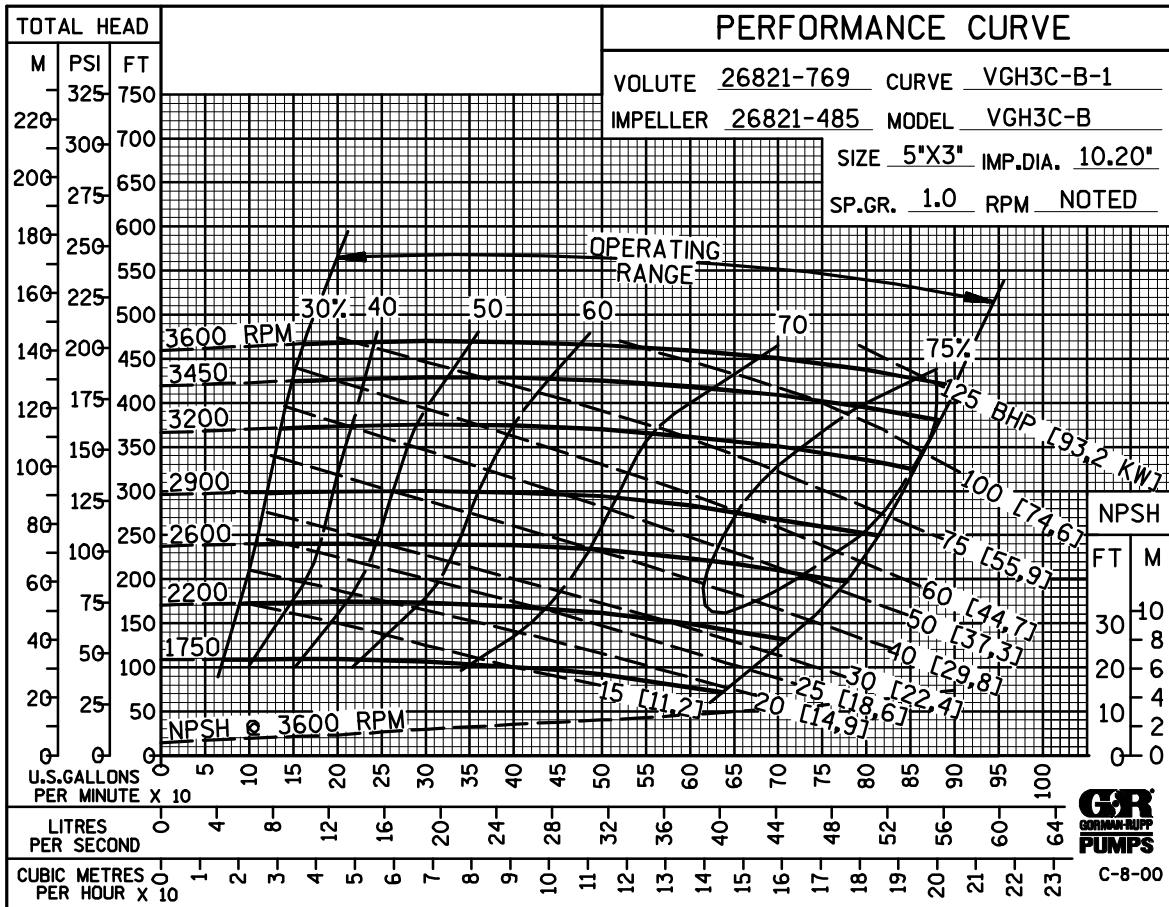

* STANDARD PERFORMANCES FOR PUMP MODEL VGH3C31-B

* Based on 70° F (21° C) clear water at sea level with minimum suction lift. Since pump installations are seldom identical, your performance may be difference due to such factors as viscosity, specific gravity, elevation, temperature, and impeller trim.

Contact the Gorman-Rupp Company to verify performance or part numbers.



Pump speed and operating condition points must be within the continuous performance range shown on the curve.

If your pump serial number is followed by an "N", your pump is **NOT** a standard production model.

SECTION DRAWING

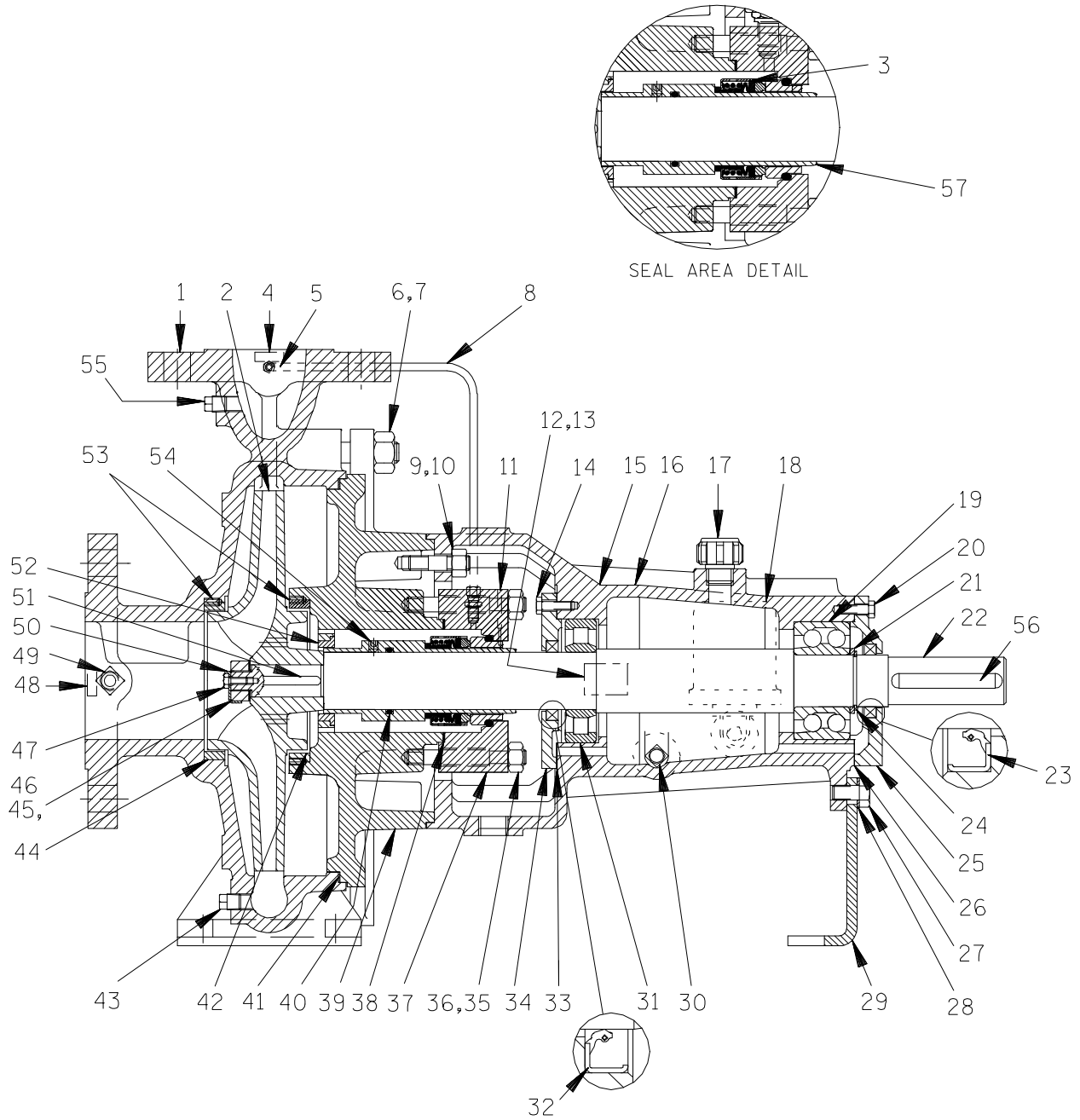

Figure 1. Pump Assembly VGH3C31-B

PARTS LIST
Pump Assembly VGH3C31-B
 (From S/N 1379872 Up)

If your pump serial number is followed by an "N", your pump is **NOT** a standard production model. Contact the Gorman-Rupp Company to verify part numbers.

ITEM NO.	PART NAME	PART NUMBER	MAT'L CODE	QTY	ITEM NO.	PART NAME	PART NUMBER	MAT'L CODE	QTY
1	PUMP CASING	26821-769	----	1	32 *	OIL SEAL	26821-637	----	1
2 *	IMPELLER	26821-485	----	1	33 *	BEARING COVER GASKET	26821-409	----	1
3 *	SEAL ASSY	26821-596	----	1	34	BEARING COVER	26821-802	----	1
4	DISCHARGE DECAL	6588BJ	----	1	35	HEX NUT	26821-932	----	4
5	MALE COUPLING	26821-982	----	2	36	STUD	26821-901	----	4
6	STUD	26821-893	----	8	37	SEAL FLANGE	26821-249	----	1
7	HEX NUT	26821-934	----	8	38 *	SEAL FLANGE GASKET	26821-468	----	1
8	PIPE	26821-981	----	1	39	SEAL PLATE	26821-712	----	1
9	STUD	26821-878	----	4	40 *	O-RING	25154-224	----	1
10	HEX NUT	26821-932	----	4	41 *	SEAL PLATE GASKET	26821-422	----	1
11	PIN	26821-984	----	1	42 *	WEAR RING	26821-783	----	1
12	NAME PLATE	38814-068	13000	1	43	PIPE PLUG	P06	15079	1
13	DRIVE SCREW	BM#04-03	17000	2	44	WEAR RING	26821-783	----	1
14	HEX HD CAPSCREW	22645-036	----	4	45	IMPELLER NUT	26821-139	----	1
15	BEARING HOUSING	26821-062	----	1	46	IMPELLER WASHER	K14	----	1
16	ROTATION DECAL	2613M	----	1	47	HEX HD CAPSCREW	22645-128	----	1
17	OIL INLET PLUG	26821-616	----	1	48	SUCTION DECAL	6588AG	----	1
18	CONSTANT LEVEL OILER	26821-617	----	1	49	PIPE PLUG	P04	15079	1
19 *	BEARING	26821-334	----	1	50	SAFETY PLATE	26821-192	----	1
20	HEX HD CAPSCREW	22645-039	----	4	51 *	IMPELLER KEY	26821-833	----	1
21	BEARING SPACER	26821-326	----	2	52	THROAT BUSHING	26821-973	----	1
22 *	IMPELLER SHAFT	26821-855	----	1	53	SOC HD SET SCREW	26821-941	----	2
23 *	OIL SEAL	26821-639	----	1	54	SOC HD SETSCREW	26821-943	----	2
24	SNAP RING	26821-386	----	1	55	PIPE PLUG	P06	15079	2
25	BEARING COVER	26821-805	----	1	56 *	SHAFT KEY	N0411	15990	1
26 *	BEARING COVER GASKET	26821-410	----	1	57	SHAFT SLEEVE	26821-229	----	1
27	HEX HD CAPSCREW	22645-160	----	1	NOT SHOWN:				
28	WASHER	K06	15991	1		DRY SHIP CAUTION TAG	38816-326	----	1
29	SUPPORT FOOT	26821-215	----	1		INSTRUCTION TAG	38817-011	----	1
30	PIPE PLUG	P04	15079	1		INSTRUCTION TAG	38817-024	----	1
31 *	BEARING	26821-352	----	1		OIL LEVEL SIGHT GAUGE	26821-611	----	1

* INDICATES PARTS RECOMMENDED FOR STOCK

PUMP AND SEAL DISASSEMBLY AND REASSEMBLY

Review all Safety information in Section A.

Follow the instructions on all tags, label and decals attached to the pump.

This pump requires little service due to its rugged, minimum-maintenance design. However, if it becomes necessary to inspect or replace the wearing parts, follow these instructions which are keyed to the sectional view (see Figure 1) and the accompanying parts list.

This manual will alert personnel to known procedures which require special attention, to those which could damage equipment, and to those which could be dangerous to personnel. However, this manual cannot possibly anticipate and provide detailed precautions for every situation that might occur during maintenance of the unit. Therefore, it is the responsibility of the owner/maintenance personnel to ensure that **only** safe, established maintenance procedures are used, and that any procedures not addressed in this manual are performed **only** after establishing that neither personal safety nor pump integrity are compromised by such practices.

Before attempting to service the pump, disconnect the power source or take other precautions to ensure that it will remain inoperative. Close all valves in the suction and discharge lines.

For power source disassembly and repair, consult the literature supplied with the power source, or contact your local power source representative.



Before attempting to open or service the pump:

1. **Familiarize yourself with this manual.**
2. **Lock out or disconnect the power source to ensure that the pump will remain inoperative.**
3. **Allow the pump to completely cool if overheated.**

4. **Check the temperature before opening any covers, plates, or plugs.**
5. **Close the suction and discharge valves.**
6. **Vent the pump slowly and cautiously.**
7. **Drain the pump.**



If this pump has been approved for use with volatile and/or flammable liquids, be certain proper safety practices are followed before operating or servicing the pump. Provide adequate ventilation, prohibit smoking, wear static-resistant clothing and shoes. Clean up all fuel spills immediately after occurrence.



Death or serious personal injury and damage to the pump or components can occur if proper lifting procedures are not observed. Make certain that hoists, chains, slings or cables are in good working condition and of sufficient capacity and that they are positioned so that loads will be balanced and the pump or components will not be damaged when lifting. Suction and discharge hoses and piping must be removed from the pump before lifting. Lift the pump or component only as high as necessary and keep personnel away from suspended objects.

Pump Casing and Impeller Removal

For access to the impeller (2) or seal assembly (3), the pump casing (1) must be separated from the seal plate (39).

Drain the suction and discharge piping and disconnect them from the pump. Remove the casing drain plug (43) and drain the pump. Clean and reinstall the drain plug.

Disconnect the bypass pipe (8) at the couplings (5) in the pump casing and seal flange (37).

Remove the hardware securing the pump casing to the base. Wedge a block of wood under the bearing housing (15) to support the housing when the casing is removed.

Remove the hex nuts (7) and separate the pump casing from the seal plate. Tie and tag any leveling shims used under the casing mounting feet. Remove the seal plate gasket (41) and clean the mating surfaces.

Immobilize the impeller shaft (22). Remove the impeller hardware (45, 46, 47 and 50). Using a soft-faced mallet, tap the impeller from the shaft. Retain the impeller key (51). Inspect the impeller and replace it if cracked or badly worn.

Wear Ring Removal

Inspect the wear rings (42 and 44) for excessive wear or scoring. The wear rings are secured in the seal plate by the set screws (53) and a press fit. If replacement is required, remove the set screws. Using a small bit, drill two holes through each of the wear rings horizontally, 180° apart. Use a chisel or other suitable tool to complete the cuts through the wear rings, and remove them. **Use caution** not to damage the pump casing or seal plate when removing the wear rings.

Seal Removal

(Figures 1 and 2)

To remove the seal assembly (3), remove the nuts (10 and 35) securing the seal plate (39) to the bearing housing (15) and seal flange (37). Slide the seal plate and gasket (38) off the shaft (22).

Loosen the set screw (54) securing the shaft sleeve (57) to the shaft. Slide the sleeve, seal assembly and seal flange off the shaft as a unit.

Slide the shaft sleeve and rotating portion of the seal out of the seal flange. Remove the O-ring (40) from the groove in the I.D. of the sleeve. Lubricate the shaft sleeve with light oil and work it up under the rubber bellows. Slide the rotating portion of the seal off the shaft sleeve.

Unscrew the pin (11) and press the stationary seal seat and O-ring out of the seal flange.

If no further disassembly is required, see **Seal Installation**.

Shaft and Bearing Removal And Disassembly

When the pump is properly operated and maintained, the bearing housing should not require disassembly. Disassemble the shaft and bearings **only** when there is evidence of wear or damage.



Shaft and bearing disassembly in the field is not recommended. These operations should be performed only in a properly-equipped shop by qualified personnel.

Remove the shaft key (56).

Remove the hardware (27 and 28) securing the foot (29) to the base, and move the bearing housing to a clean, well-equipped shop for disassembly.

Remove the constant level oiler (18) from the bearing housing. Remove the drain plug (28) and drain the oil from the bearing housing. Clean and reinstall the drain plug.

Disengage the hardware (14 and 20) and remove the inboard and outboard bearing covers (25 and 34) and gaskets (26 and 33). Inspect the oil seals (23 and 32) and, if replacement is required, use a screwdriver or other suitable tool to pry them from the bearing covers.

Place a block of wood against the impeller end of the shaft and tap the shaft and assembled bearing (19) out of the bearing housing.

The inner ring for the roller bearing (31) will be removed with the shaft, while the outer ring and rollers will remain in the bearing housing. Press the outer ring and rollers out of the bearing housing from the back side. There are puller notches on the back side of the inner ring. Use a suitable puller to remove the inner ring from the shaft.

Remove the snap ring (24) and outboard bearing spacer (21). Use a bearing puller to remove the

outboard bearing (19) from the shaft. Remove the inboard bearing spacer (21).

After removing the shaft and bearings, clean and inspect the bearings as follows.



It is **strongly** recommended that the bearings be replaced **any** time the shaft and bearings are removed.

Clean the bearing housing, shaft and all component parts (except the bearings) with a soft cloth soaked in cleaning solvent. Inspect the parts for wear or damage and replace as necessary.



Most cleaning solvents are toxic and flammable. Use them only in a well ventilated area free from excessive heat, sparks, and flame. Read and follow all precautions printed on solvent containers.

Clean the bearings thoroughly in **fresh** cleaning solvent. Dry the bearings with filtered compressed air and coat with light oil.



Bearings must be kept free of all dirt and foreign material. Failure to do so will greatly shorten bearing life. **Do not** spin dry bearings. This may scratch the balls or races and cause premature bearing failure.

Rotate the bearings by hand to check for roughness or binding and inspect the bearing rollers and balls. If rotation is rough or the bearing rollers or balls are discolored, replace the bearings.

Replace the bearings, shaft, or bearing housing as required if the proper bearing fit is not achieved.

Shaft and Bearing Reassembly And Installation

Clean and inspect the bearings as indicated in **Shaft and Bearing Removal and Disassembly**.



It is **strongly** recommended that the bearings be replaced **any** time the shaft and bearings are removed.

The outboard bearing (19) and the inner race of the inboard bearing (31) may be heated to ease installation. An induction heater, hot oil bath, electric oven, or hot plate may be used to heat the bearing. Bearings should **never** be heated with a direct flame or directly on a hot plate.

NOTE

*If a hot oil bath is used to heat the bearing, both the oil and the container must be **absolutely** clean. If the oil has been previously used, it must be **thoroughly** filtered.*

Install the inboard bearing spacer (21).

Heat the outboard bearing and inner race of the inboard bearing (31) to a uniform temperature **no higher than 250°F (120°C)**, and slide the bearings it onto the shaft, one at a time, until fully seated. This should be done quickly, in one continuous motion, to prevent the bearings from cooling and sticking on the shaft.



Use caution when handling hot bearings to prevent burns.

After the bearings have been installed and allowed to cool, check to ensure that they have not moved out of position in shrinking. If movement has occurred, use a suitably sized sleeve and a press to reposition the bearings.



When installing the bearings onto the shaft, **never** press or hit against the outer

race, rollers, balls, or ball cage. Press **only** on the inner race.

If heating the bearings is not practical, use a suitably sized sleeve and an arbor (or hydraulic) press to install the bearings on the shaft.

Install the outboard bearing spacer (21). Install the snap ring (24) in the groove in the impeller shaft.

Position the bearing housing on a secure work surface with the drive end facing up. Slide the shaft into the bearing housing until the bearing (19) seats against the bearing bore shoulder.

Press the oil seal (23) into the bearing cover (25) with the lip positioned as shown in Figure 1. Install the gasket (26) and secure the bearing cover to the bearing housing (15) with the capscrews (20).

Position the bearing housing on a secure work surface with the seal plate end facing up. Press the outer ring and rollers of the inboard bearing (31) into the bearing housing until fully seated.

Install the inboard oil seal (32) in the bearing cover (34) with the lip positioned as shown in Figure 1. Slide the inboard bearing cover and gasket (33) over the shaft and secure them with the capscrews (14).

Secure the foot (29) to the bearing housing with the hardware (27 and 28). Support the bearing housing with a wood block until the pump is fully reassembled. Lubricate the bearings as indicated in **LUBRICATION** at the end of this section.

Wear Ring Installation

Inspect the throat bushing (52) for wear or scoring. If replacement is required, position the seal plate on the bed of an arbor (or hydraulic) press with the impeller end facing up and use a suitably sized dowel to press the bushing from the seal plate bore.

Invert the seal plate on the press and use a suitably sized sleeve to install a new bushing in the seal plate.



The throat bushing **must** seat squarely in the seal plate bore; otherwise binding and/or excessive wear will result.

If the wear rings (42 and 44) were removed for replacement, press the replacement rings into the pump casing and seal plate until they seat squarely against the shoulders.

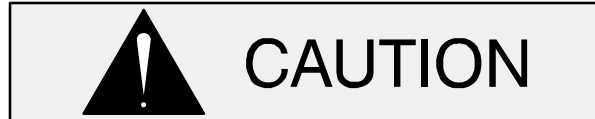

The wear rings **must** seat squarely in the casing and seal plate bores; otherwise binding and/or excessive wear will result.

The wear rings are held in place with M5 x 10mm setscrews (53). With the wear rings installed in the pump casing and seal plate, drill a 4 mm diameter by 12mm deep hole between the O.D. of the wear ring and the I.D. of the pump casing and seal plate. Tap the hole with an M5 tap, and secure the wear rings by installing the set screws (53).

NOTE

3/16–24 x 3/8 SAE setscrews may be substituted for the M6 x 6mm metric setscrews. Drill and tap the holes accordingly if using SAE setscrews.

Seal Installation

(Figures 1 and 2)

Clean the seal cavity and shaft with a cloth soaked in fresh cleaning solvent.



Most cleaning solvents are toxic and flammable. Use them only in a well ventilated area free from excessive heat, sparks, and flame. Read and follow all precautions printed on solvent containers.

Inspect the shaft for damage. Small scratches or nicks may be removed with a fine file or emery cloth. If excessive wear exists, replace the shaft.



A new seal assembly should be installed **any time** the old seal is removed from the pump. Reusing an old seal could result in premature failure.

The seal is not normally reused because wear patterns on the finished faces cannot be realigned during reassembly. This could result in premature failure. If necessary to reuse an old seal in an emergency, **carefully** wash all metallic parts in **fresh** cleaning solvent and allow to dry thoroughly.

Do not attempt to separate the seal, this could damage the seal. Individual parts are not sold separately.

Inspect the seal for wear, scoring, grooves, and other damage that might cause leakage. If any components are worn, replace the seal.

If a replacement seal is being used, remove it from the container and inspect it to ensure that it is free of any foreign matter.

To ease installation of the seal and seal plate, lubricate the seal sleeve O-ring with water or a very **small** amount of oil. See Figure 2 for seal part identification.

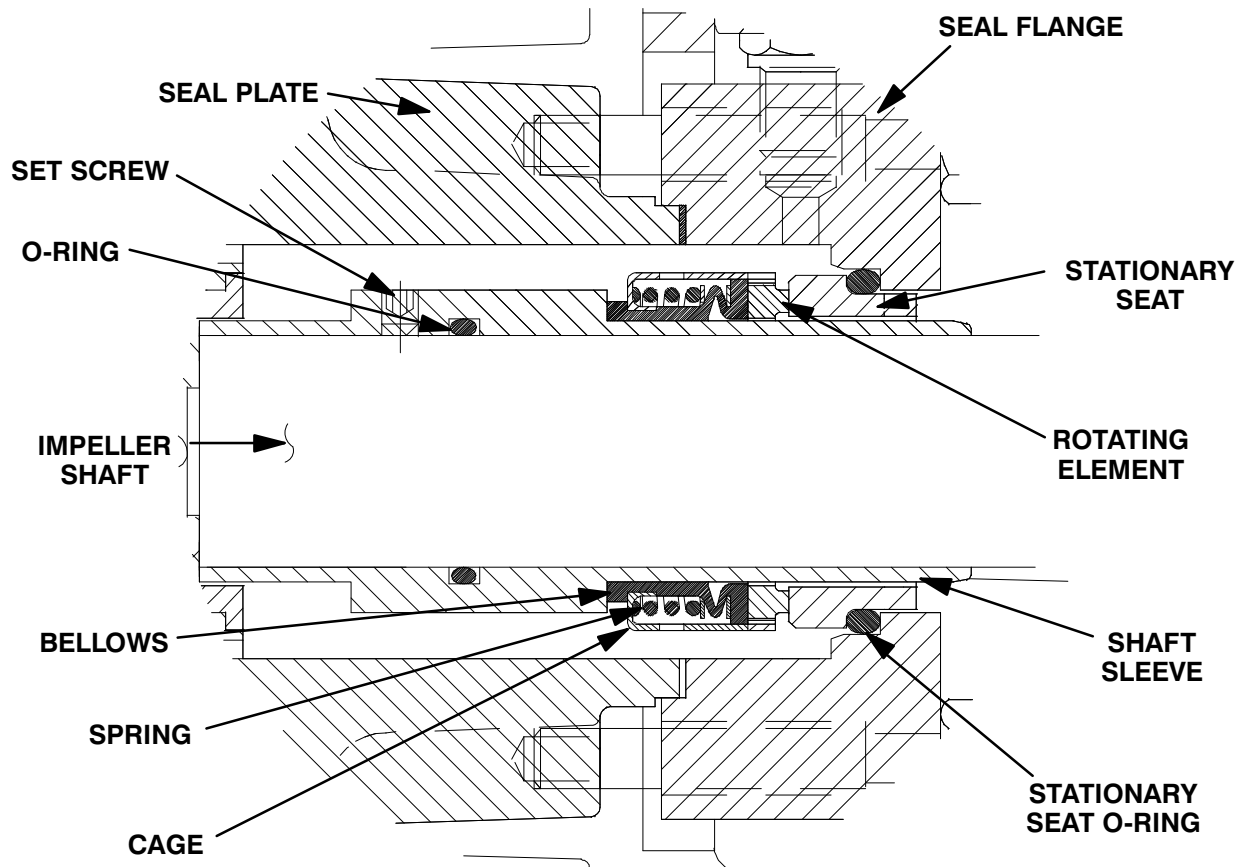

Figure 2. Cartridge Seal Assembly



This seal is not designed for operation at temperatures above 160°F (71°C). Do not use at higher operating temperatures.

Lubricate the O-ring (40) with water or light oil and install it in the groove in the I.D. of the shaft sleeve (57). Lubricate the O.D. of the sleeve in the area of the seal with water or light oil and slide the rotating portion of the seal onto the shaft until it is fully seated against the step on the O.D. of the shaft sleeve.

Lubricate the stationary seat O-ring with water or light oil and install it on the O.D. of the stationary seat. Align the hole in the stationary seat with the hole for the pin (11) in the seal flange (37) and use thumb pressure to press the stationary seat and O-ring into the seal flange until fully seated. After installation, wipe the stationary seat face in a concentric pattern with a clean, lint-free cloth to remove any fingerprints. Screw the pin into the seal flange to secure the stationary seat.

Carefully slide the assembled stationary seat and flange over the end of the shaft sleeve until the seal faces contact.

Slide the assembled shaft sleeve, seal and seal flange over the shaft until the impeller end of the sleeve is **just flush** with the shaft shoulder. Secure the sleeve to the shaft with the setscrew (54).

Install a new gasket (38) in the step on the front of the seal flange.

Align the studs (9 and 36) with the holes in the bearing housing and seal flange and slide the seal plate (39) over the shaft until the step on the O.D. of the seal plate is fully seated in the bearing housing. **Make sure** the coupling (5) in the seal flange is properly aligned for installation of the vent line (8). Secure the seal plate to the bearing housing with the nuts (10).

Secure the seal flange to the seal plate with the nuts (35).

Impeller and Pump Casing Installation

Inspect the impeller, and replace it if cracked or badly worn. Install the impeller key (51) in the shaft keyway. Align the impeller keyway with the key and slide the impeller onto the shaft until fully seated.

NOTE

After the impeller has been properly positioned, check for free rotation. Correct any scraping/binding before further reassembly.

When the impeller is properly positioned, install the impeller washer and nut (45 and 46). Secure the impeller nut with the safety plate (50) and screw (47).

Install the casing gasket (41). Slide the pump casing (1) over the impeller and secure it to the seal plate with the nuts (7).

Reinstall the bypass pipe (8).

NOTE

After the pump casing has been installed, check the impeller for free rotation and correct any scraping or binding.

Final Pump Assembly

Remove the wood block supporting the bearing housing. Secure the pump and bearing housing foot to the base with the previously removed hardware. Be sure to reinstall any leveling shims used under the pump mounting feet.

Be sure the pump and power source are securely mounted to the base. Reinstall the shaft key (55) and install the power source coupling.

Install the suction and discharge lines. Make certain that all piping connections are tight, properly supported and secure. Open all the valves in the suction and discharge lines.

Be sure the pump and power source have been properly lubricated, see **LUBRICATION**.

Fill the pump casing with clean liquid. Refer to **OPERATION**, Section C, before putting the pump back into service.

LUBRICATION

Seal Assembly

The seal assembly is lubricated by the medium being pumped and no additional lubrication is required.

Bearings

The bearing housing was not lubricated when shipped from the factory. To lubricate the bearing cavity, fill the constant level oiler as shown in Figure 3 with SAE No. 30 non-detergent oil, then close the oiler and allow the oil to drain into the bearing cavity. Repeat this procedure until oil no longer drains from the constant level oiler.

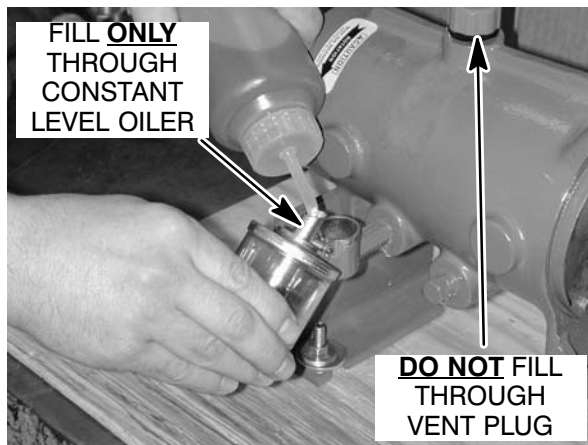

Figure 3. Lubricating Bearing Cavity

Do not fill the bearing cavity through the vent plug in the top of the housing. This will result in over-filling, and can cause leakage, excessive heat build-up and/or premature bearing failure.

Check the oil level regularly through the constant level oiler and add oil as required.

Under normal conditions, drain the bearing housing once each year and refill with clean oil. Change the oil more frequently if the pump is operated continuously or installed in an environment with rapid temperature change.



Monitor the condition of the bearing lubricant regularly for evidence of rust or moisture condensation. This is especially important in areas where variable hot and cold temperatures are common.

For cold weather operation, consult the factory or a lubricant supplier for the recommended grade of oil.

Power Source

Consult the literature supplied with the power source, or contact your local power source representative.

**For Warranty Information, Please Visit
www.grpumps.com/warranty
or call:
U.S.: 419-755-1280
Canada: 519-631-2870
International: +1-419-755-1352**

GORMAN-RUPP PUMPS