

**INSTALLATION, OPERATION,
AND MAINTENANCE MANUAL**
WITH PARTS LIST



PA SERIES PUMP

| MODEL |
|------------------------|
| PA12A60-B-6068H |

THE GORMAN-RUPP COMPANY • MANSFIELD, OHIO

GORMAN-RUPP OF CANADA LIMITED • ST. THOMAS, ONTARIO, CANADA Printed in U.S.A

www.grpumps.com

©2009 The Gorman-Rupp Company

Register your new
Gorman-Rupp pump online at
www.grpumps.com

Valid serial number and e-mail address required.



The engine exhaust from this product contains chemicals known to the State of California to cause cancer, birth defects or other reproductive harm.

RECORD YOUR PUMP MODEL AND SERIAL NUMBER

Please record your pump model and serial number in the spaces provided below. Your Gorman-Rupp distributor needs this information when you require parts or service.

Pump Model: _____

Serial Number: _____

TABLE OF CONTENTS

| | |
|------------------------------------------------------|-------------------|
| INTRODUCTION | PAGE I – 1 |
| SAFETY - SECTION A | PAGE A – 1 |
| INSTALLATION – SECTION B | PAGE B – 1 |
| Pump Dimensions | PAGE B – 1 |
| PREINSTALLATION INSPECTION | PAGE B – 1 |
| Battery Installation | PAGE B – 2 |
| POSITIONING PUMP | PAGE B – 2 |
| Lifting | PAGE B – 2 |
| Mounting | PAGE B – 2 |
| SUCTION AND DISCHARGE PIPING | PAGE B – 3 |
| Materials | PAGE B – 3 |
| Line Configuration | PAGE B – 3 |
| Connections to Pump | PAGE B – 3 |
| Gauges | PAGE B – 3 |
| SUCTION LINES | PAGE B – 3 |
| Fittings | PAGE B – 3 |
| Strainers | PAGE B – 3 |
| Sealing | PAGE B – 4 |
| Suction Line Positioning | PAGE B – 4 |
| DISCHARGE LINES | PAGE B – 5 |
| Siphoning | PAGE B – 5 |
| Valves | PAGE B – 5 |
| ALIGNMENT | PAGE B – 5 |
| AUTO-START | PAGE B – 5 |
| Float Switch Installation | PAGE B – 6 |
| OPERATION – SECTION C | PAGE C – 1 |
| OPERATION | PAGE C – 1 |
| PRIMING | PAGE C – 1 |
| STARTING | PAGE C – 1 |
| Manual Starting | PAGE C – 1 |
| Automatic Starting | PAGE C – 2 |
| OPERATION | PAGE C – 2 |
| Leakage | PAGE C – 2 |
| Pump Vacuum Check | PAGE C – 2 |
| Liquid Temperature And Overheating | PAGE C – 2 |
| Strainer Check | PAGE C – 2 |
| STOPPING | PAGE C – 3 |
| BEARING TEMPERATURE CHECK | PAGE C – 3 |
| Cold Weather Preservation | PAGE C – 3 |
| TROUBLESHOOTING – SECTION D | PAGE D – 1 |
| PREVENTIVE MAINTENANCE | PAGE D – 3 |
| PUMP MAINTENANCE AND REPAIR - SECTION E | PAGE E – 1 |
| STANDARD PERFORMANCE CURVE | PAGE E – 1 |

TABLE OF CONTENTS
(continued)

PARTS LIST:

| | |
|----------------------------------------------------------|--------------------|
| Pump Model Assembly | PAGE E – 3 |
| Pump Assembly | PAGE E – 5 |
| Engine Modification | PAGE E – 9 |
| Pump Sub-Assembly | PAGE E – 11 |
| Pump End Assembly | PAGE E – 13 |
| Priming Chamber Kit | PAGE E – 16 |
| Priming Chamber Assembly | PAGE E – 17 |
| Engine Drive Assembly | PAGE E – 18 |
| PUMP AND SEAL DISASSEMBLY AND REASSEMBLY | PAGE E – 19 |
| Priming Chamber Removal And Disassembly | PAGE E – 20 |
| Discharge Check Valve Removal and Disassembly | PAGE E – 20 |
| Suction Head And Wear Ring Removal | PAGE E – 20 |
| Pump Casing Removal | PAGE E – 21 |
| Impeller Removal | PAGE E – 21 |
| Seal Removal | PAGE E – 21 |
| Pedestal Assembly Removal | PAGE E – 21 |
| Pump Shaft and Bearing Removal and Disassembly | PAGE E – 22 |
| Engine Drive Disassembly | PAGE E – 22 |
| Bearing Cleaning And Inspection | PAGE E – 23 |
| Engine Drive Reassembly | PAGE E – 23 |
| Pump Shaft and Bearing Reassembly and Installation | PAGE E – 25 |
| Pedestal Assembly Installation | PAGE E – 26 |
| Seal Reassembly and Installation | PAGE E – 27 |
| Impeller Installation | PAGE E – 28 |
| Pump Casing Installation | PAGE E – 29 |
| Suction Head And Wear Ring Installation | PAGE E – 29 |
| Discharge Check Valve Assembly and Installation | PAGE E – 29 |
| Priming Chamber Assembly And Installation | PAGE E – 30 |
| LUBRICATION | PAGE E – 30 |
| Seal Assembly | PAGE E – 30 |
| Bearings | PAGE E – 30 |
| Engine | PAGE E – 30 |

INTRODUCTION

Thank You for purchasing a Gorman-Rupp pump. **Read this manual** carefully to learn how to safely install and operate your pump. Failure to do so could result in personal injury or damage to the pump. This Installation, Operation, and Maintenance manual is designed to help you achieve the best performance and longest life from your Gorman-Rupp pump.

This pump is a PA Series, priming-assisted environmental silent pump. The centrifugal pump unit is designed for handling non-volatile, non-flammable liquids containing specified entrained solids. The basic material of pump construction is ductile iron, with stainless steel shaft and ductile iron wearing parts.

Because pump installations are seldom identical, this manual cannot possibly provide detailed instructions and precautions for every aspect of each specific application. Therefore, it is the responsibility of the owner/installer of the pump to ensure that applications not addressed in this manual are performed **only** after establishing that neither operator safety nor pump integrity are compromised by the installation. Pumps and related equipment **must** be installed and operated according to all national, local and industry standards.

If there are any questions regarding the pump which are not covered in this manual or in other literature accompanying the unit, please contact your Gorman-Rupp distributor or the Gorman-Rupp Company:

The Gorman-Rupp Company
P.O. Box 1217
Mansfield, Ohio 44901—1217
Phone: (419) 755—1011

or:

Gorman-Rupp of Canada Limited
70 Burwell Road
St. Thomas, Ontario N5P 3R7
Phone: (519) 631—2870

For information or technical assistance on the engine, contact the engine manufacturer's local dealer or representative.

The following are used to alert personnel to procedures which require special attention, to those which could damage equipment, and to those which could be dangerous to personnel:



Immediate hazards which WILL result in severe personal injury or death. These instructions describe the procedure required and the injury which will result from failure to follow the procedure.



Hazards or unsafe practices which COULD result in severe personal injury or death. These instructions describe the procedure required and the injury which could result from failure to follow the procedure.



Hazards or unsafe practices which COULD result in minor personal injury or product or property damage. These instructions describe the requirements and the possible damage which could result from failure to follow the procedure.

NOTE

Instructions to aid in installation, operation, and maintenance or which clarify a procedure.

SAFETY - SECTION A

This information applies to Prime Aire® Series pumps. Refer to the manual accompanying the engine or power source before attempting to begin operation.

Because pump installations are seldom identical, this manual cannot possibly provide detailed instructions and precautions for each specific application. Therefore, it is the owner/installer's responsibility to ensure that applications not addressed in this manual are performed only after establishing that neither operator safety nor pump integrity are compromised by the installation.



Before attempting to open or service the pump:

1. Familiarize yourself with this manual.
2. Shut down the engine and disconnect the positive battery cable to ensure that the pump will remain inoperative.
3. Allow the pump to completely cool if overheated.
4. Check the temperature and make sure the pump is cool before opening any covers, plates, or plugs.
5. Close the suction and discharge valves.
6. Vent the pump slowly and cautiously.
7. Drain the pump.



This pump is equipped with an automatic starting system, and is subject to automatic restart. Keep hands and clothing away from the unit to prevent injury during automatic operation. Disconnect

the positive battery cable before performing any maintenance. Failure to do so may result in serious personal injury.



This pump is designed to handle most non-volatile, non-flammable liquids containing specified entrained solids. Do not attempt to pump volatile, corrosive, or flammable liquids which may damage the pump or endanger personnel as a result of pump failure.



Death or serious personal injury and damage to the pump or components can occur if proper lifting procedures are not observed. Make certain that hoists, chains, slings or cables are in good working condition and of sufficient capacity and that they are positioned so that loads will be balanced and the pump or components will not be damaged when lifting. Suction and discharge hoses and piping must be removed from the pump before lifting. Lift the pump or component only as high as necessary and keep personnel away from suspended objects.



After the pump has been installed, make certain that the pump and all piping or hose connections are tight, properly supported and secure before operation.



Do not operate the pump against a closed discharge valve. If operated against a closed discharge valve, pump

components will deteriorate, and the liquid could come to a boil, build pressure, and cause the pump casing to rupture or explode. Momentary closure of a discharge valve is acceptable **only** when required for startup or shutdown procedures.



Do not remove plates, covers, gauges, pipe plugs, or fittings from an overheated pump. Vapor pressure within the pump can cause parts being disengaged to be ejected with great force. Allow the pump to cool completely before servicing.



This pump may be used to handle materials which could cause illness through direct exposure or emitted fumes. Wear adequate protective clothing when working on the pump or piping.



Do not operate the pump without guards in place over the rotating parts. Exposed rotating parts can catch clothing, fingers or tools, causing severe injury to personnel.



Make sure the pump is level. Lower jack stands and chock the wheels, if so equipped. Use caution when positioning the skid-mounted unit to prevent damage to the fuel tank.



Do not operate an internal combustion engine in an explosive atmosphere. When operating an internal combustion engine in an enclosed area, make sure exhaust fumes are piped to the outside. These fumes contain carbon monoxide, a deadly gas that is colorless, tasteless and odorless.



Fuel used by internal combustion engines presents an extreme explosion and fire hazard. Make certain that all fuel lines are securely connected and free of leaks. Never refuel a hot or running engine. Avoid overfilling the fuel tank. Always use the correct type of fuel.



Never tamper with the governor to gain more power. The governor establishes safe operating limits that should not be exceeded. Refer to the Performance Curve in Section, Page E-1 for the maximum continuous operating speed for this pump.

INSTALLATION – SECTION B

Review all SAFETY information in Section A.

Since pump installations are seldom identical, this section offers only general recommendations and practices required to inspect, position, and arrange the pump and piping.

Most of the information pertains to a standard **static lift** application where the pump is positioned above the free level of liquid to be pumped.

If installed in a **flooded suction application** where the liquid is supplied to the pump under pressure, some of the information such as mounting, line

configuration, and priming must be tailored to the specific application. Since the pressure supplied to the pump is critical to performance and safety, **be sure** to limit the incoming pressure to 50% of the maximum permissible operating pressure as shown on the pump performance curve.

For further assistance, contact your Gorman-Rupp distributor or the Gorman-Rupp Company.

Pump Dimensions

See Figure 1 for the approximate physical dimensions of this pump.

OUTLINE DRAWING

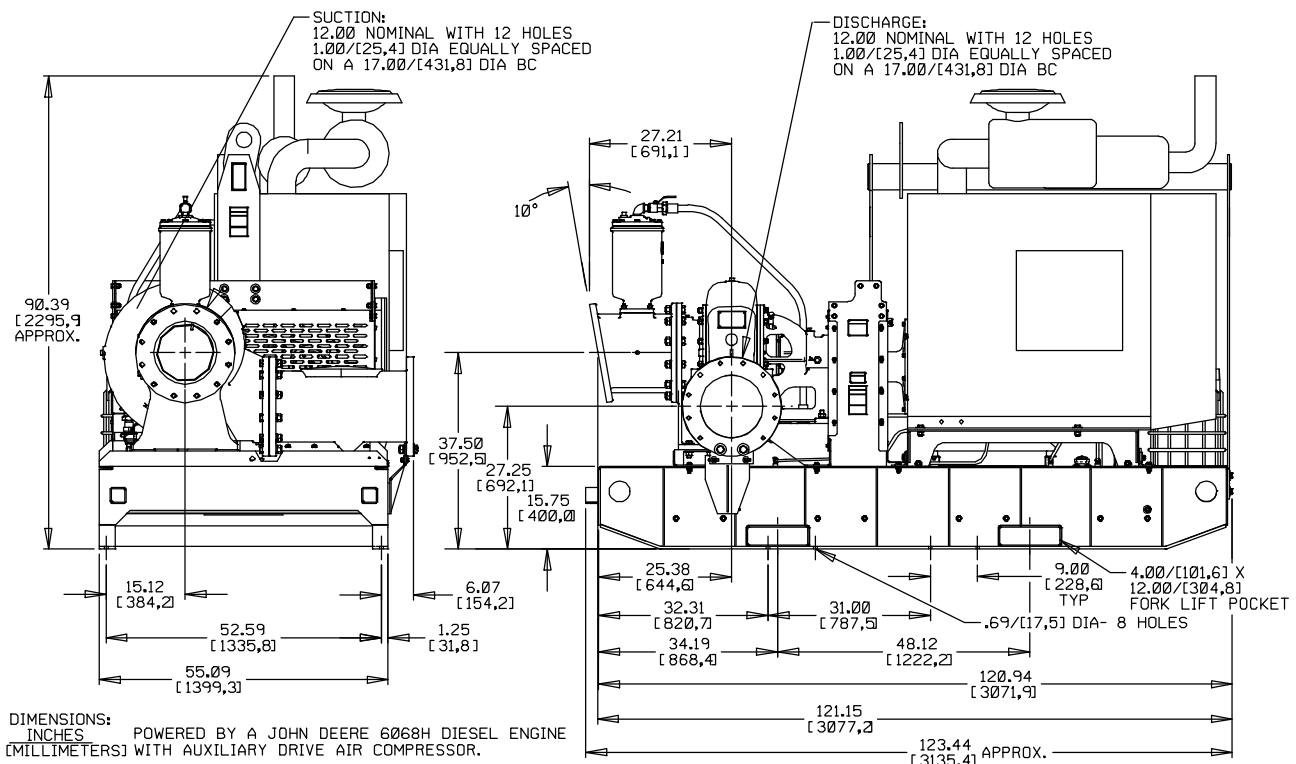

Figure 1. Pump Model PA12A60-B-6068H

PREINSTALLATION INSPECTION

The pump assembly was inspected and tested before shipment from the factory. Before installation, inspect the pump for damage which may have occurred during shipment. Check as follows:

- Inspect the pump for cracks, dents, damaged threads, and other obvious damage.
- Check for and tighten loose attaching hardware. Since gaskets tend to shrink after drying, check for loose hardware at mating surfaces.

- c. Carefully read all tags, decals, and markings on the pump assembly, and perform all duties indicated. Note that the pump shaft rotates in the required direction.



Only operate this pump in the direction indicated by the arrow on the pump body and on the accompanying decal. Otherwise, the impeller could become loosened from the shaft and seriously damage the pump.

- d. Check levels and lubricate as necessary. Refer to **LUBRICATION** in the **Maintenance and Repair Manual** and perform duties as instructed.
- e. If the pump has been stored for more than 12 months, some of the components or lubricants may have exceeded their maximum shelf life. These **must be inspected or replaced** to ensure maximum pump service.

If the maximum shelf life has been exceeded, or if anything appears to be abnormal, contact your Gorman-Rupp distributor or the factory to determine the repair or updating policy. **Do not** put the pump into service until appropriate action has been taken.

Battery Installation

Unless otherwise specified on the pump order, the engine battery is **not** included with engine driven units.

Refer to the information accompanying the battery and/or electrolyte solution for activation and charging instructions.

Before installing the battery, clean the positive and negative cable connectors, and the battery terminals. Secure the battery by tightening the holddown brackets. The terminals and clamps may be coated with petroleum jelly to retard corrosion. Connect and tighten the positive cable first, then the negative cable.

POSITIONING PUMP



Death or serious personal injury and damage to the pump or components can occur if proper lifting procedures are not observed. Make certain that hoists, chains, slings or cables are in good working condition and of sufficient capacity and that they are positioned so that loads will be balanced and the pump or components will not be damaged when lifting. Suction and discharge hoses and piping must be removed from the pump before lifting. Lift the pump or component only as high as necessary and keep personnel away from suspended objects.

Lifting

Pump unit weights will vary depending on the mounting and drive provided. Check the shipping tag on the unit packaging for the actual weight, and use lifting equipment with appropriate capacity. Drain the pump and remove all customer-installed equipment such as suction and discharge hoses or piping before attempting to lift existing, installed units.

Mounting

Locate the pump in an accessible place as close as practical to the liquid being pumped. Level mounting is essential for proper operation. The pump may have to be supported or shimmed to provide for level operation and eliminate vibration.

For engine driven units, the pump **must** be positioned as level as possible to ensure sufficient lubrication and fuel supply to the engine.

If the pump has been mounted on a moveable base, make certain the base is stationary by setting the brake and blocking the wheels before attempting to operate the pump.



If the pump has been mounted on a movable base, do not attempt to operate the pump unless the unit is level. Be sure the leveling stands are positioned on a solid surface, and the wheels are chocked.

SUCTION AND DISCHARGE PIPING

Pump performance is adversely effected by increased suction lift, discharge elevation, and friction losses. See the performance curve and operating range shown on Page E-1 to be sure your overall application allows pump to operate within the safe operation range.

Materials

Either pipe or hose may be used for suction and discharge lines; however, the materials must be compatible with the liquid being pumped. If hose is used in suction lines, it must be the rigid-wall, reinforced type to prevent collapse under suction. Using piping couplings in suction lines is not recommended.

Line Configuration

Keep suction and discharge lines as straight as possible to minimize friction losses. Make minimum use of elbows and fittings, which substantially increase friction loss. If elbows are necessary, use the long-radius type to minimize friction loss.

Connections to Pump

Before tightening a connecting flange, align it exactly with the pump port. Never pull a pipe line into place by tightening the flange bolts and/or couplings.

Lines near the pump must be independently supported to avoid strain on the pump which could cause excessive vibration, decreased bearing life, and increased shaft and seal wear. If hose-type lines are used, they should have adequate support

to secure them when filled with liquid and under pressure.

Gauges

The pump is drilled and tapped for installing discharge pressure and vacuum suction gauges. It is recommended that gauges be installed to monitor pump performance. Seal the gauge threads with pipe dope to ensure an airtight seal. Follow the sealant manufacturer's recommendations when selecting and applying the pipe dope. The pipe dope should be compatible with the liquid being pumped.

SUCTION LINES

To avoid air pockets which could affect pump priming, the suction line must be as short and direct as possible. When operation involves a suction lift, the line must always slope upward to the pump from the source of the liquid being pumped; if the line slopes down to the pump at any point along the suction run, air pockets will be created.

Fittings

Suction lines should be the same size as the pump inlet. If reducers are used in suction lines, they should be the eccentric type, and should be installed with the flat part of the reducers uppermost to avoid creating air pockets. Valves are not normally used in suction lines, but if a valve is used, install it with the stem horizontal to avoid air pockets.

Strainers

A strainer or other device should be used to filter solids larger than the pump's capacity to avoid damage or decreased performance. Information about solids size handling can be found on the performance curve for your specific pump. When selecting or installing a strainer, make certain that the total area of the openings in the strainer is at least three or four times the cross section of the suction line, and the openings will not permit passage of solids larger than the solids handling capability of the pump.

Sealing

Since even a slight leak will affect priming, head, and capacity, especially when operating with a high suction lift, all connections in the suction line should be sealed with pipe dope to ensure an air-tight seal. Follow the sealant manufacturer's recommendations when selecting and applying the pipe dope. The pipe dope should be compatible with the liquid being pumped.

Suction Lines In Sumps

If a single suction line is installed in a sump, it should be positioned away from the wall of the sump at a distance equal to 1 1/2 times the diameter of the suction line.

If there is a liquid flow from an open pipe into the sump, the flow should be kept away from the suction inlet because the inflow will carry air down into the sump, and air entering the suction line will reduce pump efficiency.

If it is necessary to position inflow close to the suction inlet, install a baffle between the inflow and the suction inlet at a distance 1-1/2 times the diameter of the suction pipe. The baffle will allow entrained

air to escape from the liquid before it is drawn into the suction inlet.

If two suction lines are installed in a single sump, the flow paths may interact, reducing the efficiency of one or both pumps. To avoid this, position the suction inlets so that they are separated by a distance equal to at least 3 times the diameter of the suction pipe.

Suction Line Positioning

The depth of submergence of the suction line is critical to **efficient** pump operation. Figure 2 shows recommended minimum submergence vs. velocity.

Although not recommended, the vacuum assisted priming feature allows the pump to be operated temporarily in a "slurping" application with varying water levels.

NOTE

The pipe submergence required may be reduced by installing a standard pipe increaser fitting at the end of the suction line. The larger opening size will reduce the inlet velocity. Calculate the required submergence using the following formula based on the increased opening size (area or diameter).

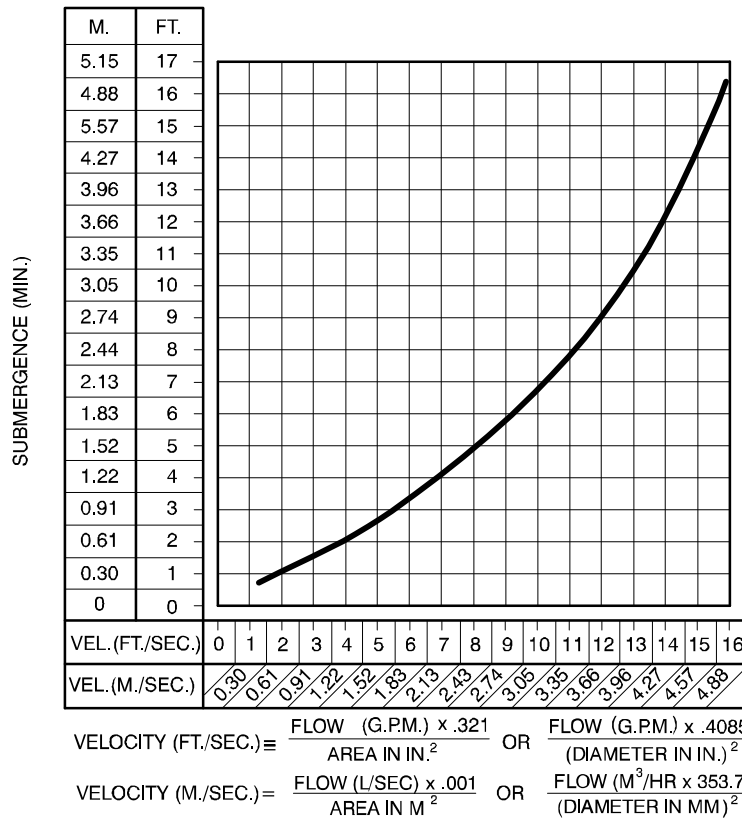

Figure 2. Recommended Minimum Suction Line Submergence vs. Velocity

DISCHARGE LINES

Siphoning

Do not terminate the discharge line at a level lower than that of the liquid being pumped unless a siphon breaker is used in the line. Otherwise, a siphoning action causing damage to the pump could result.

Valves

This pump is designed with a check valve in the discharge line.

If a throttling valve is desired in the discharge line, use a valve as large as the largest pipe to minimize friction losses. Never install a throttling valve in a suction line.

With high discharge heads, it is recommended that a throttling valve be installed in the discharge line to protect the pump from excessive shock pressure and reverse rotation when it is stopped.



If the application involves a high discharge head, gradually close the discharge throttling valve before stopping the pump.

ALIGNMENT

The alignment of the pump, air compressor and engine is critical for trouble-free mechanical operation. See Section E, **Securing Intermediate And Drive Assembly To Engine** in **MAINTENANCE AND REPAIR**, for details.

AUTO-START

The standard pump is equipped with an auto-start control system which allows the pump to start and stop as the liquid level in the wet well or sump rises and falls.

Refer to the information which follows for installation details for the liquid level sensing system provided with your pump.

Float Switch Installation

The Float Switch autostart system employs either a single or double float switch, where a bulb raises or lowers (floats) with the liquid level, thus activating an enclosed miniature switch. The floats are equipped with a socket type connector that plugs into a matching receptacle on the auto-start control box.

Standard floats are equipped with 50 feet (15,2 m) of cable.

When installing the floats, note the following:

- a. **Be sure** to provide sufficient room in the wet well or sump so that floats do not get obstructed or drawn into the suction line. If a flexible suction hose is used, it may be extended to lay along the bottom of the wet well or sump and the float can be attached to the hose above the point where it bends along the bottom. Direct the suction line toward the flow, and the float(s) away from the flow. If a stand-

pipe is available, attach the float switch cable to the standpipe in the sump at the approximate desired liquid level.

- b. In a single float system, the cable can be tethered to the suction line or standpipe approximately 6 inches (152 mm) above the float. This setting allows approximately 9 inches (229 mm) of liquid rise between pump start/stop. The start/stop interval may be increased by extending the float end of the cable. The liquid level in the sump will increase approximately 8 inches (203 mm) between start/stop intervals for every 6 inches (152 mm) of cable increase.
- c. If a double float switch system is used, position the "Start" float at the desired high water level in the sump, and the "Stop" float at the desired low water level in the pump.
- d. Refer to Figure 3 for additional float switch data.

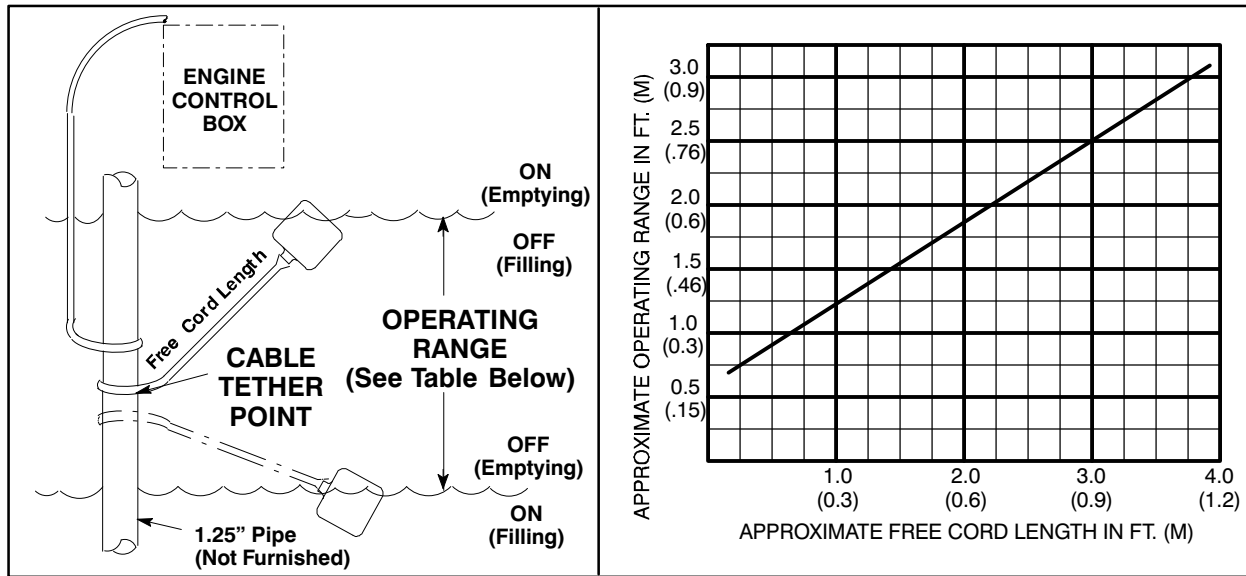

Figure 3. Float Switch Data

OPERATION – SECTION C

Review all **SAFETY** information in Section A.

Follow the instructions on all tags, labels and decals attached to the pump.



Do not operate an internal combustion engine in an explosive atmosphere. When operating an internal combustion engine in an enclosed area, make sure exhaust fumes are piped to the outside. These fumes contain carbon monoxide, a deadly gas that is colorless, tasteless and odorless.

OPERATION



This pump is designed to handle most non-volatile, non-flammable liquids containing specified entrained solids. Do not attempt to pump volatile, corrosive, or flammable liquids which may damage the pump or endanger personnel as a result of pump failure.



Pump speed and operating condition points must be within the continuous performance range shown on the performance curve in Section E on page E-1.

PRIMING

Install the pump and piping as described in **INSTALLATION**. Make sure that the piping connections are tight, and that the pump is securely mounted. Check that the pump is properly lubricated (see **LUBRICATION** in **MAINTENANCE AND REPAIR**).

The pump will begin to prime upon startup. The air in the suction line will be discharged from the educator discharge line. Complete priming is indicated by a positive discharge pressure reading.

If full priming is not achieved, the discharge check valve may be malfunctioning. If this occurs, shut down the pump and consult **Maintenance and Repair**, Section E for further details.

STARTING

Check the fuel level and oil levels in the engine, air compressor, pump bearings and seal housing.

Make sure the pump is level. Lower the jack stands and chock the wheels, if so equipped.



Make sure the pump is level. Lower jack stands and chock the wheels, if so equipped. Use caution when positioning the skid-mounted unit to prevent damage to the fuel tank.



This pump is equipped with an automatic starting system, and is subject to automatic restart. Keep hands and clothing away from the unit to prevent injury during automatic operation. Disconnect the positive battery cable before performing any maintenance. Failure to do so may result in serious personal injury.

Consult the engine operations manual before attempting to start the unit.

Manual Starting

On initial start-up, set the engine speed at in the half-throttle position. Turn the keyswitch to 'MANUAL'. After the engine starts and the unit is fully primed, adjust the engine RPM until the desired flow rate is achieved.

Automatic Starting

With the float system installed, follow the procedures outlined for manual starting and throttle adjustment. Switch the keyswitch to 'OFF' until the water level rises above the on point for the float system, then turn the keyswitch to the 'AUTO' setting. The unit will run until the float signals the control that the water in the wet well is at the float off point, at which time the unit will shut down automatically. When the float signals the control that the water in the wet well is at the float on point, the unit will restart automatically, repeating the cycle.

OPERATION

Leakage

Once the pump is fully primed, no leakage should be visible at pump mating surfaces, or at pump connections or fittings. Keep all line connections and fittings tight to maintain maximum pump efficiency.

Pump Vacuum Check

Read the vacuum gauge with the pump primed and at operation speed. Shut off the pump. The vacuum gauge reading will immediately drop proportionate to static suction lift, and should then stabilize. If the vacuum reading falls off rapidly after stabilization, an air leak exists. Before checking for the source of the leak, check the point of installation of the vacuum gauge.

Liquid Temperature And Overheating

The **maximum** liquid temperature for this pump is 160° F (71° C). Do not apply it at a higher operating temperature.

Overheating can occur if operated with the valves in the suction or discharge lines closed. Operating against closed valves could bring the liquid to a boil, build pressure, and cause the pump to rupture or explode. If overheating occurs, stop the pump immediately and allow it to completely cool before servicing it. **Approach any over-heated pump cautiously.**



Allow an over-heated pump to completely cool before servicing. Do not remove plates, covers, gauges, or fittings from an overheated pump. Liquid within the pump can reach boiling temperatures, and vapor pressure within the pump can cause parts being disengaged to be ejected with great force. After the pump cools, drain the liquid from the pump by removing the casing drain plug. Use caution when removing the plug to prevent injury to personnel from hot liquid.

As a safeguard against rupture or explosion due to heat, this pump is equipped with a pressure relief valve which will open if vapor pressure within the pump casing reaches a critical point. If over-heating does occur, stop the pump immediately and allow it to cool before servicing it. **Approach any over-heated pump cautiously.** It is recommended that the pressure relief valve assembly be replaced at each overhaul, or any time the pump casing over-heats and activates the valve. **Never** replace this valve with a substitute which has not been specified or provided by the Gorman-Rupp Company.

Strainer Check

Check the strainer regularly, and clean it as necessary. The strainer should also be checked if pump flow rate begins to drop. Monitor and record the vacuum suction gauge readings regularly to detect strainer blockage.

Never introduce air or steam pressure into the pump casing or piping to remove a blockage. This could result in personal injury or damage to the equipment. If backflushing is absolutely necessary, **liquid pressure** must be limited to 50% of the maximum permissible operating pressure shown on the pump performance curve.

STOPPING

Never halt the flow of liquid suddenly. If the liquid being pumped is stopped abruptly, damaging

shock waves can be transmitted to the pump and piping system. Close all connecting valves slowly.

Reduce the throttle speed slowly and allow the engine to idle briefly before stopping.

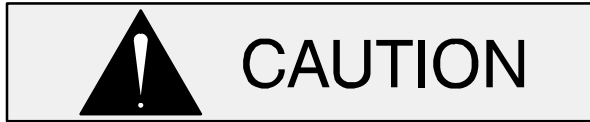

If the application involves a high discharge head, gradually close the discharge throttling valve before stopping the pump.

After stopping the pump, switch off the engine ignition and remove the key to ensure that the pump will remain inoperative.

BEARING TEMPERATURE CHECK

Bearings normally run at higher than ambient temperatures because of heat generated by friction. Temperatures up to 160°F (71°C) are considered normal for bearings, and they can operate safely to at least 180°F (82°C).

Checking bearing temperatures by hand is inaccurate. Bearing temperatures can be measured accurately by placing a contact-type thermometer against the housing. Record this temperature for future reference.

A sudden increase in bearing temperatures is a warning that the bearings are at the point of failing to operate properly. Make certain that the bearing lubricant is of the proper viscosity and at the correct level (see **LUBRICATION** in the Maintenance and Repair Manual). Bearing overheating can also be caused by shaft misalignment and/or excessive vibration.

When pumps are first started, the bearings may seem to run at temperatures above normal. Continued operation should bring the temperatures down to normal levels.

Cold Weather Preservation

In below freezing conditions, drain the pump to prevent damage from freezing. Also, clean out any solids by flushing with a hose. Operate the pump for approximately one minute; this will remove any remaining liquid that could freeze the pump rotating parts. If the pump will be idle for more than a few hours, or if it has been pumping liquids containing a large amount of solids, drain the pump, and flush it thoroughly with clean water. To prevent large solids from clogging the drain port and preventing the pump from completely draining, insert a rod or stiff wire in the drain port, and agitate the liquid during the draining process. Clean out any remaining solids by flushing with a hose.

TROUBLESHOOTING – SECTION D

Review all SAFETY information in Section A.



Before attempting to open or service the pump:

1. Familiarize yourself with this manual.
2. Shut down the engine and disconnect the positive battery cable to ensure that the pump will remain inoperative.
3. Allow the pump to completely cool if overheated.
4. Check the temperature before opening any covers, plates, or plugs.

5. Close the suction and discharge valves.
6. Vent the pump slowly and cautiously.
7. Drain the pump.



This pump is equipped with an automatic starting system, and is subject to automatic restart. Keep hands and clothing away from the unit to prevent injury during automatic operation. Disconnect the positive battery cable before performing any maintenance. Failure to do so may result in serious personal injury.

| TROUBLE | POSSIBLE CAUSE | PROBABLE REMEDY |
|-------------------------------------------------------|-----------------------------------------------------------------------------------------------------------------------------------------------------------------------------------------------------------------------------------------------------------------------------------------------|----------------------------------------------------------------------------------------------------------------------------------------------------------------------------------------------------------------------------------------------------------------------------------------------------------------|
| PUMP FAILS TO PRIME | Discharge check valve contaminated, damaged, or unable to seat. Air leak in suction line. Lining of suction hose collapsed. Leaking or worn seal or pump gasket. Suction lift or discharge head too high. Air compressor damaged or belts broken. Strainer clogged. | Clean or replace check valve. Correct leak. Replace suction hose. Check pump vacuum. Replace leaking or worn seal or gasket. Check piping installation and install bypass line if needed. See INSTALLATION . Check and repair/replace. Check strainer and clean if necessary. |
| PUMP STOPS OR FAILS TO DELIVER RATED FLOW OR PRESSURE | Eductor clogged. Air leak in suction line. Lining of suction hose collapsed. Leaking or worn seal or pump gasket. | Check and clean eductor. Correct leak. Replace suction hose. Check pump vacuum. Replace leaking or worn seal or gasket. |

| TROUBLE | POSSIBLE CAUSE | PROBABLE REMEDY |
|---------------------------------------------------------------|-----------------------------------------------------------------------------------------------------------------------------------------------------------------------------------------------------------------------------------------------------------------------------------------------------------------------------------------------------------|-----------------------------------------------------------------------------------------------------------------------------------------------------------------------------------------------------------------------------------------------------------------------------------------------------------------------------------------------------------------------------------------------------------------------------------------------------------------------------------------------------------|
| PUMP STOPS OR FAILS TO DELIVER RATED FLOW OR PRESSURE (cont.) | <p>Strainer clogged.</p> <p>Discharge check valve clogged.</p> <p>Suction intake not submerged at proper level or sump too small.</p> <p>Impeller or other wearing parts worn or damaged.</p> <p>Impeller clogged.</p> <p>Discharge head too high.</p> <p>Suction lift too high.</p> <p>Pump speed too slow.</p> <p>Belt or flexible coupling broken.</p> | <p>Check strainer and clean if necessary.</p> <p>Check and clean check valve.</p> <p>Check installation and correct submergence as needed.</p> <p>Replace worn or damaged parts. Check that impeller is properly centered and rotates freely.</p> <p>Free impeller of debris.</p> <p>Install bypass line.</p> <p>Measure lift w/vacuum gauge. Reduce lift and/or friction losses in suction line.</p> <p>Check engine output; consult engine operation manual.</p> <p>Check and replace as necessary.</p> |
| PUMP REQUIRES TOO MUCH POWER | <p>Pump speed too high.</p> <p>Extreme ambient temperature.</p> <p>Discharge head too low.</p> <p>Fuel filter clogged.</p> <p>Liquid solution too thick.</p> <p>Fuel contaminated.</p> <p>Pump or jack shaft bearing(s) frozen.</p> | <p>Check engine output.</p> <p>Reduce pump output.</p> <p>Adjust discharge valve.</p> <p>Check & replace often in extreme operating conditions.</p> <p>Dilute if possible.</p> <p>Check and replace as required.</p> <p>Disassemble, check and replace bearing(s) as required..</p> |
| PUMP CLOGS FREQUENTLY | <p>Discharge flow too slow.</p> <p>Suction check valve or foot valve clogged or binding.</p> <p>Liquid solution too thick.</p> | <p>Open discharge valve fully to increase flow rate, and run engine at maximum governed speed.</p> <p>Clean valve.</p> <p>Dilute if possible.</p> |
| EXCESSIVE NOISE | <p>Cavitation in pump.</p> <p>Pumping entrained air.</p> <p>Pump or drive not securely mounted.</p> <p>Impeller clogged or damaged.</p> | <p>Reduce suction lift and/or friction losses in suction line. Record vacuum and pressure gauge readings and consult local representative or factory.</p> <p>Locate and eliminate source of air bubble.</p> <p>Secure mounting hardware.</p> <p>Clean out debris; replace damaged parts.</p> |

| TROUBLE | POSSIBLE CAUSE | PROBABLE REMEDY |
|----------------------|----------------------------------------------------------------------------------------------------------------------------------------------------------------------------------------------------------------|----------------------------------------------------------------------------------------------------------------------------------------------------------------------------------------------------------------------------------------------------|
| BEARINGS RUN TOO HOT | Bearing temperature is high, but within limits. Low or incorrect lubricant. Suction and discharge lines not properly supported. Drive misaligned. Excessive tension on drive belt. | Check bearing temperature regularly to monitor any increase. Check for proper type and level of lubricant. Check piping installation for proper support. Align drive properly. Check belt tension. Adjust as required. |

PREVENTIVE MAINTENANCE

Since pump applications are seldom identical, and pump wear is directly affected by such things as the abrasive qualities, pressure and temperature of the liquid being pumped, this section is intended only to provide general recommendations and practices for preventive maintenance. Regardless of the application however, following a routine preventive maintenance schedule will help assure trouble-free performance and long life from your Gorman-Rupp pump. For specific questions concerning your application, contact your Gorman-Rupp distributor or the Gorman-Rupp Company.

Record keeping is an essential component of a good preventive maintenance program. Changes in suction and discharge gauge readings (if so

equipped) between regularly scheduled inspections can indicate problems that can be corrected before system damage or catastrophic failure occurs. The appearance of wearing parts should also be documented at each inspection for comparison as well. Also, if records indicate that a certain part (such as the seal) fails at approximately the same duty cycle, the part can be checked and replaced before failure occurs, reducing unscheduled down time.

For new applications, a first inspection of wearing parts at 250 hours will give insight into the wear rate for your particular application. Subsequent inspections should be performed at the intervals shown on the chart below. Critical applications should be inspected more frequently.

| Preventive Maintenance Schedule | | | | | |
|----------------------------------------------------------------------------------------------------|-------------------|--------|---------|---------------|----------|
| Item | Service Interval* | | | | |
| | Daily | Weekly | Monthly | Semi-Annually | Annually |
| General Condition (Temperature, Unusual Noises or Vibrations, Cracks, Leaks, Loose Hardware, Etc.) | I | | | | |
| Pump Performance (Gauges, Speed, Flow) | I | | | | |
| Bearing Lubrication | | I | | | R |
| Seal Lubrication (And Packing Adjustment, If So Equipped) | | I | | | R |
| V-Belts (If So Equipped) | | | I | | |
| Air Release Valve Plunger Rod (If So Equipped) | | | I | C | |
| Front Impeller Clearance (Wear Plate) | | | | I | |
| Rear Impeller Clearance (Seal Plate) | | | | I | |
| Check Valve | | | | | I |
| Pressure Relief Valve (If So Equipped) | | | | | C |
| Pump and Driver Alignment | | | | | I |
| Shaft Deflection | | | | | I |
| Bearings | | | | | I |
| Bearing Housing | | | | | I |
| Piping | | | | | I |
| Driver Lubrication – See Mfgr’s Literature | | | | | I |

Legend:
 I = Inspect, Clean, Adjust, Repair or Replace as Necessary
 C = Clean
 R = Replace

* Service interval based on an intermittent duty cycle equal to approximately 4000 hours annually. Adjust schedule as required for lower or higher duty cycles or extreme operating conditions.

PUMP MAINTENANCE AND REPAIR – SECTION E

MAINTENANCE AND REPAIR OF THE WEARING PARTS OF THE PUMP WILL MAINTAIN PEAK OPERATING PERFORMANCE.

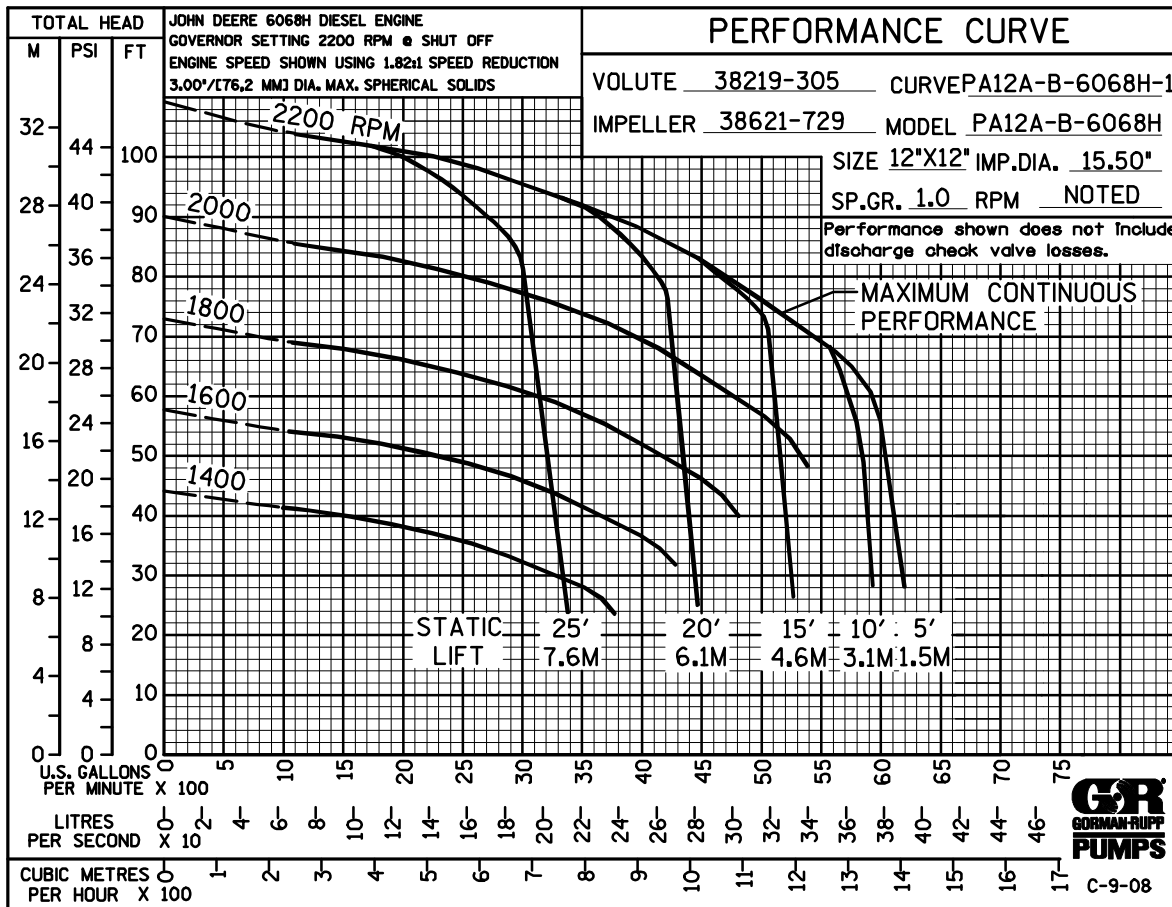

*** STANDARD PERFORMANCE FOR PUMP MODEL PA12A60-B-6068H**

* Based on 70°F (21°C) clear water at sea level with minimum suction lift. Since pump installations are seldom identical, your performance may be different due to such factors as viscosity, specific gravity, elevation, temperature, and impeller trim.

Contact the Gorman-Rupp Company to verify performance or part numbers.



CAUTION

Pump speed and operating condition points must be within the continuous performance range shown on the curve.

If your pump serial number is followed by an "N", your pump is **NOT** a standard production model.

ILLUSTRATION

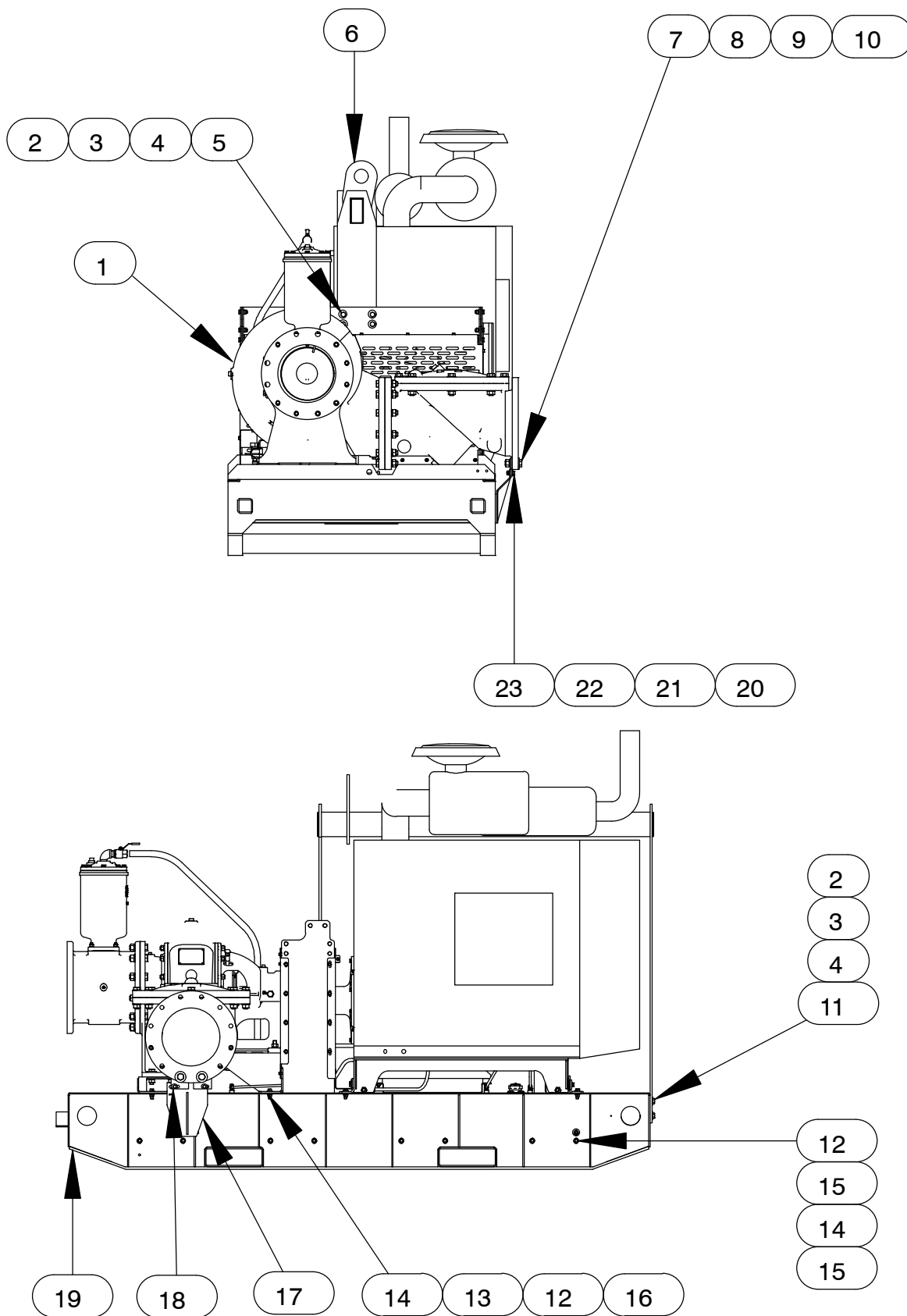

Figure 1. Pump Model PA12A60-B-6068H

PARTS LIST
Pump Model PA12A60-B-6068H
 (From S/N 1435345 Up)

If your pump serial number is followed by an "N", your pump is **NOT** a standard production model. Contact the Gorman-Rupp Company to verify part numbers.

| ITEM NO. | PART NAME | PART NUMBER | QTY |
|-------------|-------------------------------|-----------------|-----|
| 1 | PUMP SUB-ASSEMBLY | 46133-773 | 1 |
| 2 | HEX NUT | D10 15991 | 8 |
| 3 | LOCK WASHER | J10 15991 | 8 |
| 4 | FLAT WASHER | K10 15991 | 8 |
| 5 | HEX HEAD CAP SCREW | B1008 15991 | 4 |
| 6 | LIFTING BAIL ASSEMBLY | 44721-027 24150 | 1 |
| 7 | HEX HEAD CAP SCREW | B1412 15991 | 2 |
| 8 | FLAT WASHER | K14 15991 | 4 |
| 9 | LOCK WASHER | J14 15991 | 2 |
| 10 | HEX NUT | D14 15991 | 2 |
| 11 | HEX HEAD CAP SCREW | B1007 15991 | 4 |
| 12 | .50 FLAT WASHER | 21161-501 | 42 |
| 13 | HEX NUT | D08 15991 | 26 |
| 14 | LOCK WASHER | J08 15991 | 26 |
| 15 | HEX HEAD CAP SCREW | B0808 15991 | 16 |
| 16 | HEX HEAD CAP SCREW | B0807 15991 | 10 |
| 17 | CHECK VALVE SUPPORT BRKT ASSY | 41888-077 24150 | 1 |
| 18 | CHECK VALVE SUPPORT | 33643-131 15080 | 1 |
| 19 | SKID BASE | 41565-594 24150 | 1 |
| 20 | LOCK WASHER | J07 15991 | 4 |
| 21 | FLAT WASHER | K07 15991 | 8 |
| 22 | HEX NUT | D07 15991 | 4 |
| 23 | HEX HEAD CAP SCREW | B0705 15991 | 4 |
| NOT SHOWN: | | | |
| | CABLE TIE | 27111-218 | 1 |
| | FLOAT SWITCH | 48312-980 | 1 |
| | PRIME AIRE DECAL | 38812-078 | 3 |
| | G-R DECAL 6 IN | GR-06 | 2 |
| | WARNING DECAL | 38817-102 | 2 |
| | CAUTION DECAL | 2613FJ | 1 |
| | WARNING DECAL | 38816-203 | 4 |
| | WARNING DECAL | 38816-345 | 2 |
| | WARNING DECAL | 2613FE | 1 |
| | ENGINE START-UP TAG | 38816-269 | 1 |
| | INSTRUCTION DECAL | 38818-144 | 1 |
| | WARNING DECAL | 38817-101 | 2 |
| OPTIONAL: | | | |
| | BATTERY | 29331-506 | 1 |
| | STRAINER 12IN | 46641-012 24150 | 1 |

ILLUSTRATION

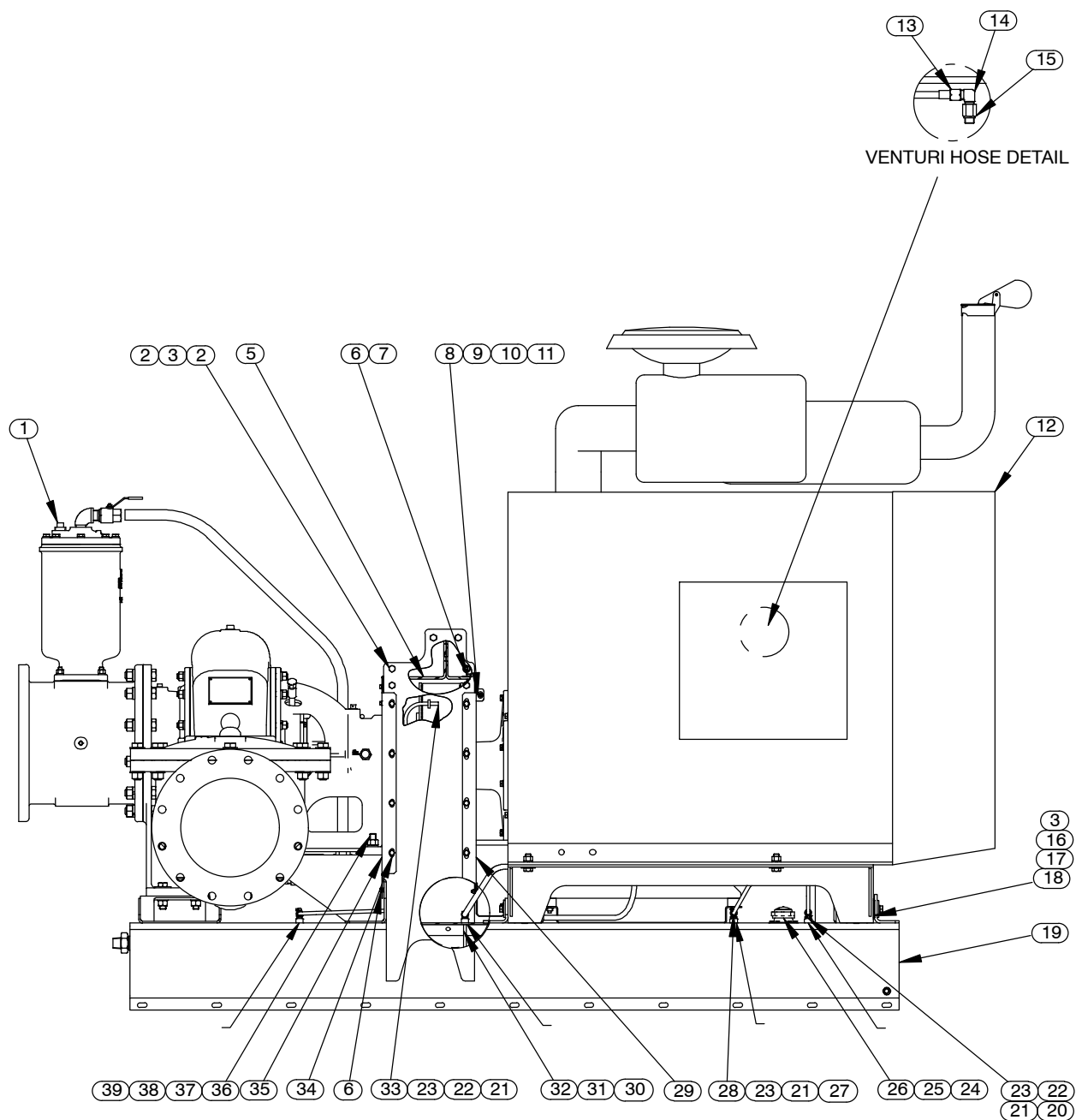

Figure 2. Pump Subassembly

PARTS LIST

Pump Subassembly

| ITEM NO. | PART NAME | PART NUMBER | QTY | ITEM NO. | PART NAME | PART NUMBER | QTY |
|----------|----------------------|-----------------|-----|----------|-----------------------|-----------------|-----|
| 1 | PUMP MODEL ASSY | 46133-726 | 1 | 34 | FLANGED CAPSCREW | 21634-515 | 16 |
| 2 | HEX HEAD CAP SCREW | B0806 15991 | 12 | 35 | GUARD - PUMP END | 34266-022 15120 | 1 |
| 3 | LOCK WASHER | J08 15991 | 18 | 36 | HEX HEAD CAP SCREW | B1211 15991 | 6 |
| 4 | HEX NUT | D08 15991 | 12 | 37 | FLAT WASHER | K12 15991 | 8 |
| 5 | HOIST BAIL SUB-ASSY | 44718-034 24150 | 1 | 38 | HEX NUT | D12 15991 | 10 |
| 6 | FLANGED CAPSCREW | 21634-505 | 18 | 39 | LOCK WASHER | J12 15991 | 8 |
| 7 | THREADED INSERT | 21769-156 | 11 | 40 | GUARD - PUMP END | 34851-524 15120 | 1 |
| 8 | FLAT WASHER | K04 15991 | 6 | 41 | PUMP GUARD ASSY | 42381-077 | 1 |
| 9 | LOCK WASHER | J04 15991 | 3 | 42 | VACUUM HOSE ASSY | 46341-021 | 1 |
| 10 | HEX HEAD CAP SCREW | B0403 15991 | 2 | 43 | HEX HEAD CAP SCREW | B1214 15991 | 2 |
| 11 | HEX NUT | D04 15991 | 3 | 44 | STRAP | 22811-259 | 3 |
| 12 | ENGINE MODIFICATION | 44311-024 | 1 | 45 | LOCK WASHER | J05 15991 | 3 |
| 13 | HOSE ASSEMBLY | 46341-026 | 1 | 46 | HEX HEAD CAP SCREW | B0504 15991 | 3 |
| 14 | MALE ELBOW | 26341-310 | 1 | 47 | PIPE TEE | U08 11999 | 1 |
| 15 | HEX ADAPTER | 26523-188 | 1 | 48 | CONNECTOR | 26351-065 | 1 |
| 16 | SPACER | 33211-004 15120 | 6 | 49 | PRESSURE RELIEF VALVE | 26662-028 | 1 |
| 17 | HEX HEAD CAP SCREW | B0807 15991 | 6 | 50 | CLOSE PIPE NIPPLE | T08 15079 | 1 |
| 18 | SHIM SET | 48261-045 | 6 | 51 | REDUCER PIPE CPLNG | AE1208 15079 | 1 |
| 19 | FUEL TANK ASSEMBLY | 46711-098 | 1 | 52 | VENTURI | 26817-001 | 1 |
| 20 | FUEL LINE | 11308A | 1 | 53 | PIPE CPLG 1 | AE16 15079 | 1 |
| 21 | REDUCER PIPE BUSHING | AP0604 15079 | 3 | 54 | PIPE NIPPLE | T1608 15079 | 1 |
| 22 | ELBOW BARB 1/4 | 26523-463 | 2 | 55 | PIPE ELBOW | R16 11999 | 1 |
| 23 | HOSE CLAMP | 26518-642 | 5 | 56 * | DRIVE BELT PUMP | 24154-001 | 1 |
| 24 | TAP SCREW | 21281-444 | 6 | 57 | BUSHING | 24131-531 | 1 |
| 25 | FLANGE | 29332-151 | 1 | 58 | SPROCKET | 24271-001 | 1 |
| 26 | FUEL GAUGE | 29332-137 | 1 | 59 | DRAIN VALVE ASSY | 46346-262 | 1 |
| 27 | HOSE | 31411-188 19360 | 1 | 60 | VENTURI GUARD | 34518-020 15120 | 1 |
| 28 | ELBOW BARB 1/4 | 26523-464 | 1 | 61 | SUPPORT BRACKET | 34325-034 15120 | 1 |
| 29 | GUARD - ENGINE SIDE | 34851-525 15120 | 1 | 62 | HEX HEAD CAP SCREW | B0404 15991 | 1 |
| 30 | .37 ID X 56" LG HOSE | 18513-302 | 1 | 63 | BATTERY BOX ASSY 4D | 42432-003 | 1 |
| 31 | HOSE BARB | 26523-333 | 1 | 64 | 1/0 POS. CABLE ASSY | 47311-137 | 1 |
| 32 | FUEL PICKUP | 29332-142 | 1 | 65 | 1/0 NEG. CABLE ASSY | 47311-134 | 1 |
| 33 | FUEL LINE | 11308F | 1 | 66 | CHECK VALVE | 26641-093 | 1 |

* INDICATES PARTS RECOMMENDED FOR STOCK

ILLUSTRATION

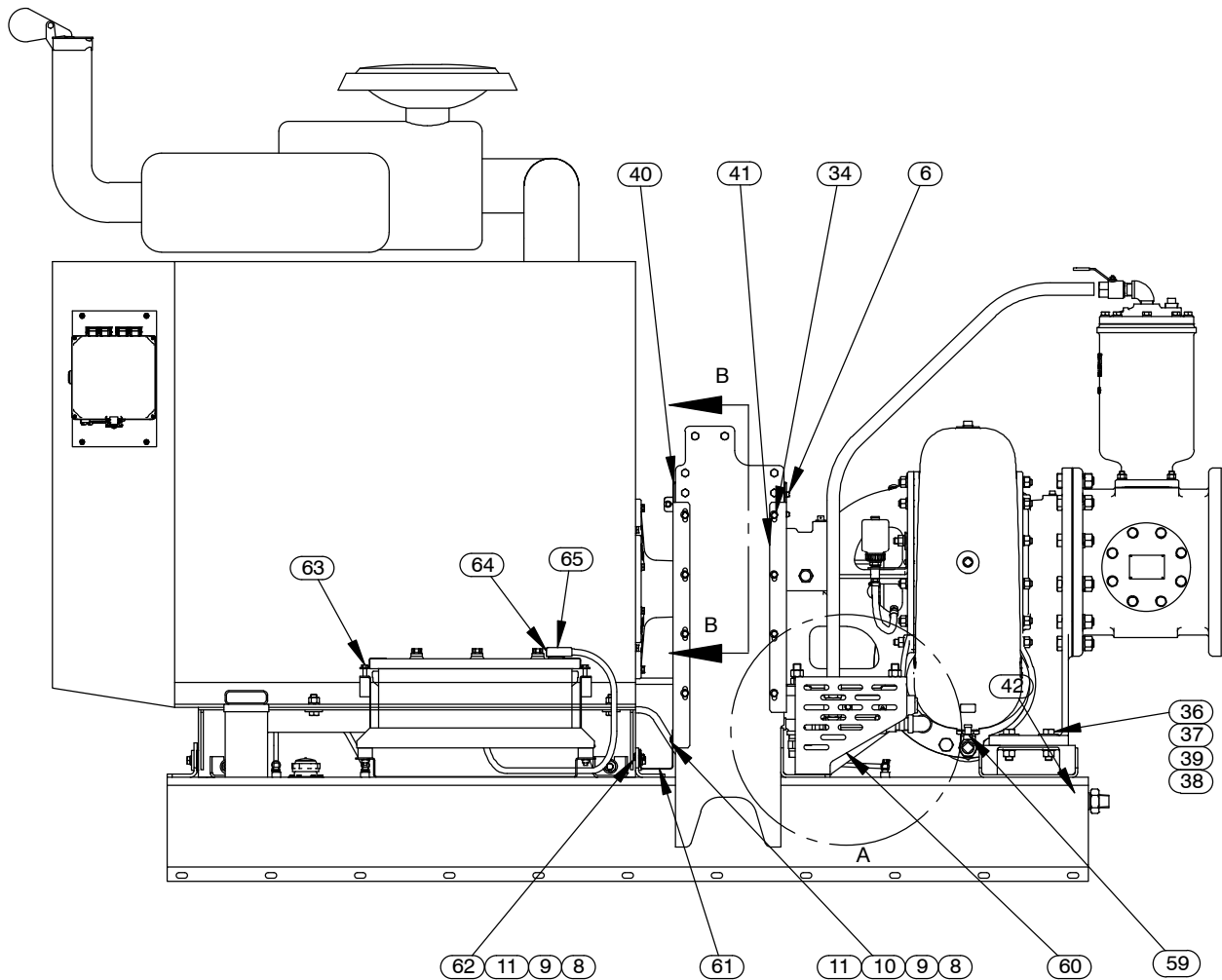
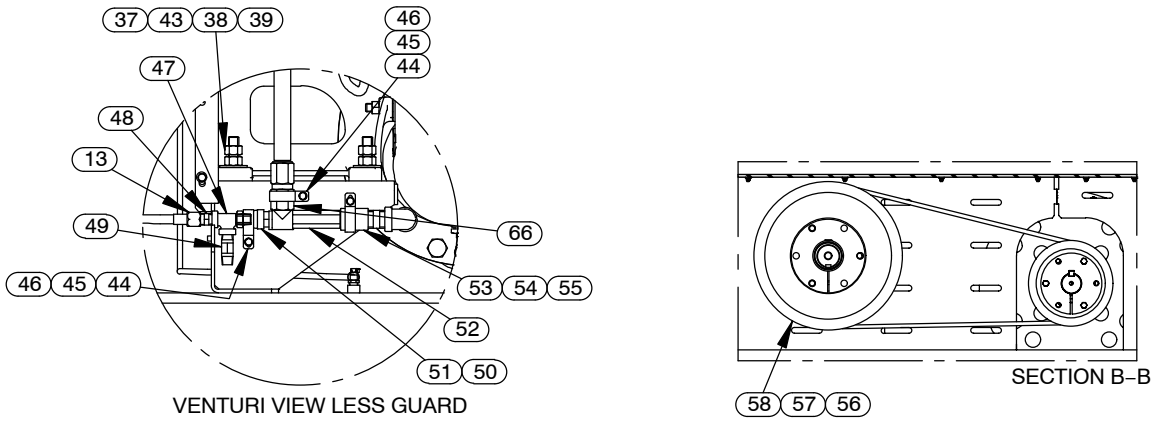

Figure 3. Pump Subassembly (cont'd)

PARTS LIST

Pump Subassembly

| ITEM NO. | PART NAME | PART NUMBER | QTY | ITEM NO. | PART NAME | PART NUMBER | QTY |
|----------|----------------------|-----------------|-----|----------|-----------------------|-----------------|-----|
| 1 | PUMP MODEL ASSY | 46133-726 | 1 | 34 | FLANGED CAPSCREW | 21634-515 | 16 |
| 2 | HEX HEAD CAP SCREW | B0806 15991 | 12 | 35 | GUARD - PUMP END | 34266-022 15120 | 1 |
| 3 | LOCK WASHER | J08 15991 | 18 | 36 | HEX HEAD CAP SCREW | B1211 15991 | 6 |
| 4 | HEX NUT | D08 15991 | 12 | 37 | FLAT WASHER | K12 15991 | 8 |
| 5 | HOIST BAIL SUB-ASSY | 44718-034 24150 | 1 | 38 | HEX NUT | D12 15991 | 10 |
| 6 | FLANGED CAPSCREW | 21634-505 | 18 | 39 | LOCK WASHER | J12 15991 | 8 |
| 7 | THREADED INSERT | 21769-156 | 11 | 40 | GUARD - PUMP END | 34851-524 15120 | 1 |
| 8 | FLAT WASHER | K04 15991 | 6 | 41 | PUMP GUARD ASSY | 42381-077 | 1 |
| 9 | LOCK WASHER | J04 15991 | 3 | 42 | VACUUM HOSE ASSY | 46341-021 | 1 |
| 10 | HEX HEAD CAP SCREW | B0403 15991 | 2 | 43 | HEX HEAD CAP SCREW | B1214 15991 | 2 |
| 11 | HEX NUT | D04 15991 | 3 | 44 | STRAP | 22811-259 | 3 |
| 12 | ENGINE MODIFICATION | 44311-024 | 1 | 45 | LOCK WASHER | J05 15991 | 3 |
| 13 | HOSE ASSEMBLY | 46341-026 | 1 | 46 | HEX HEAD CAP SCREW | B0504 15991 | 3 |
| 14 | MALE ELBOW | 26341-310 | 1 | 47 | PIPE TEE | U08 11999 | 1 |
| 15 | HEX ADAPTER | 26523-188 | 1 | 48 | CONNECTOR | 26351-065 | 1 |
| 16 | SPACER | 33211-004 15120 | 6 | 49 | PRESSURE RELIEF VALVE | 26662-028 | 1 |
| 17 | HEX HEAD CAP SCREW | B0807 15991 | 6 | 50 | CLOSE PIPE NIPPLE | T08 15079 | 1 |
| 18 | SHIM SET | 48261-045 | 6 | 51 | REDUCER PIPE CPLNG | AE1208 15079 | 1 |
| 19 | FUEL TANK ASSEMBLY | 46711-098 | 1 | 52 | VENTURI | 26817-001 | 1 |
| 20 | FUEL LINE | 11308A | 1 | 53 | PIPE CPLG 1 | AE16 15079 | 1 |
| 21 | REDUCER PIPE BUSHING | AP0604 15079 | 3 | 54 | PIPE NIPPLE | T1608 15079 | 1 |
| 22 | ELBOW BARB 1/4 | 26523-463 | 2 | 55 | PIPE ELBOW | R16 11999 | 1 |
| 23 | HOSE CLAMP | 26518-642 | 5 | 56 * | DRIVE BELT PUMP | 24154-001 | 1 |
| 24 | TAP SCREW | 21281-444 | 6 | 57 | BUSHING | 24131-531 | 1 |
| 25 | FLANGE | 29332-151 | 1 | 58 | SPROCKET | 24271-001 | 1 |
| 26 | FUEL GAUGE | 29332-137 | 1 | 59 | DRAIN VALVE ASSY | 46346-262 | 1 |
| 27 | HOSE | 31411-188 19360 | 1 | 60 | VENTURI GUARD | 34518-020 15120 | 1 |
| 28 | ELBOW BARB 1/4 | 26523-464 | 1 | 61 | SUPPORT BRACKET | 34325-034 15120 | 1 |
| 29 | GUARD - ENGINE SIDE | 34851-525 15120 | 1 | 62 | HEX HEAD CAP SCREW | B0404 15991 | 1 |
| 30 | .37 ID X 56" LG HOSE | 18513-302 | 1 | 63 | BATTERY BOX ASSY 4D | 42432-003 | 1 |
| 31 | HOSE BARB | 26523-333 | 1 | 64 | 1/0 POS. CABLE ASSY | 47311-137 | 1 |
| 32 | FUEL PICKUP | 29332-142 | 1 | 65 | 1/0 NEG. CABLE ASSY | 47311-134 | 1 |
| 33 | FUEL LINE | 11308F | 1 | 66 | CHECK VALVE | 26641-093 | 1 |

* INDICATES PARTS RECOMMENDED FOR STOCK

ILLUSTRATION

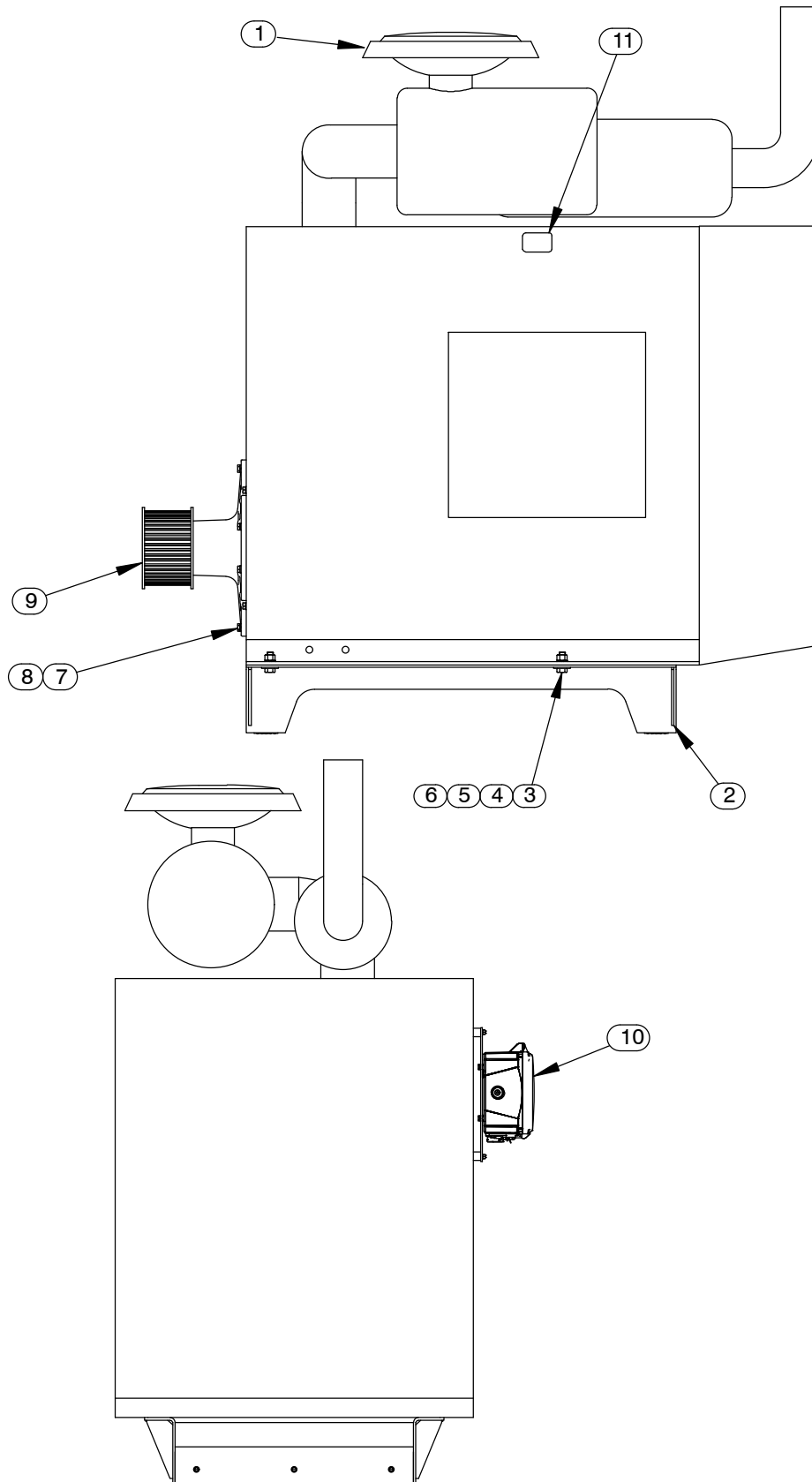

Figure 4. Engine Modification

PARTS LIST
Engine Modification

| ITEM NO. | PART NAME | PART NUMBER | QTY |
|----------|--------------------------------|-------------|-----|
| 1 | JOHN DEERE 6068H ENGINE | 29224-336 | 1 |
| 2 | PEDESTAL ASSEMBLY | 44167-506 | 1 |
| 3 | HEX HEAD CAP SCREW | B1007 15991 | 4 |
| 4 | FLAT WASHER | K10 15991 | 4 |
| 5 | LOCK WASHER | J10 15991 | 4 |
| 6 | HEX NUT | D10 15991 | 4 |
| 7 | HEX HEAD CAP SCREW | 22645-164 | 12 |
| 8 | LOCK WASHER | 21171-511 | 12 |
| 9 | ENGINE DRIVE ASSEMBLY | 44162-179 | 1 |
| 10 | CONTROL PANEL INSTALLATION KIT | 48122-544 | 1 |
| 11 | WARNING DECAL | 38816-132 | 2 |

ILLUSTRATION

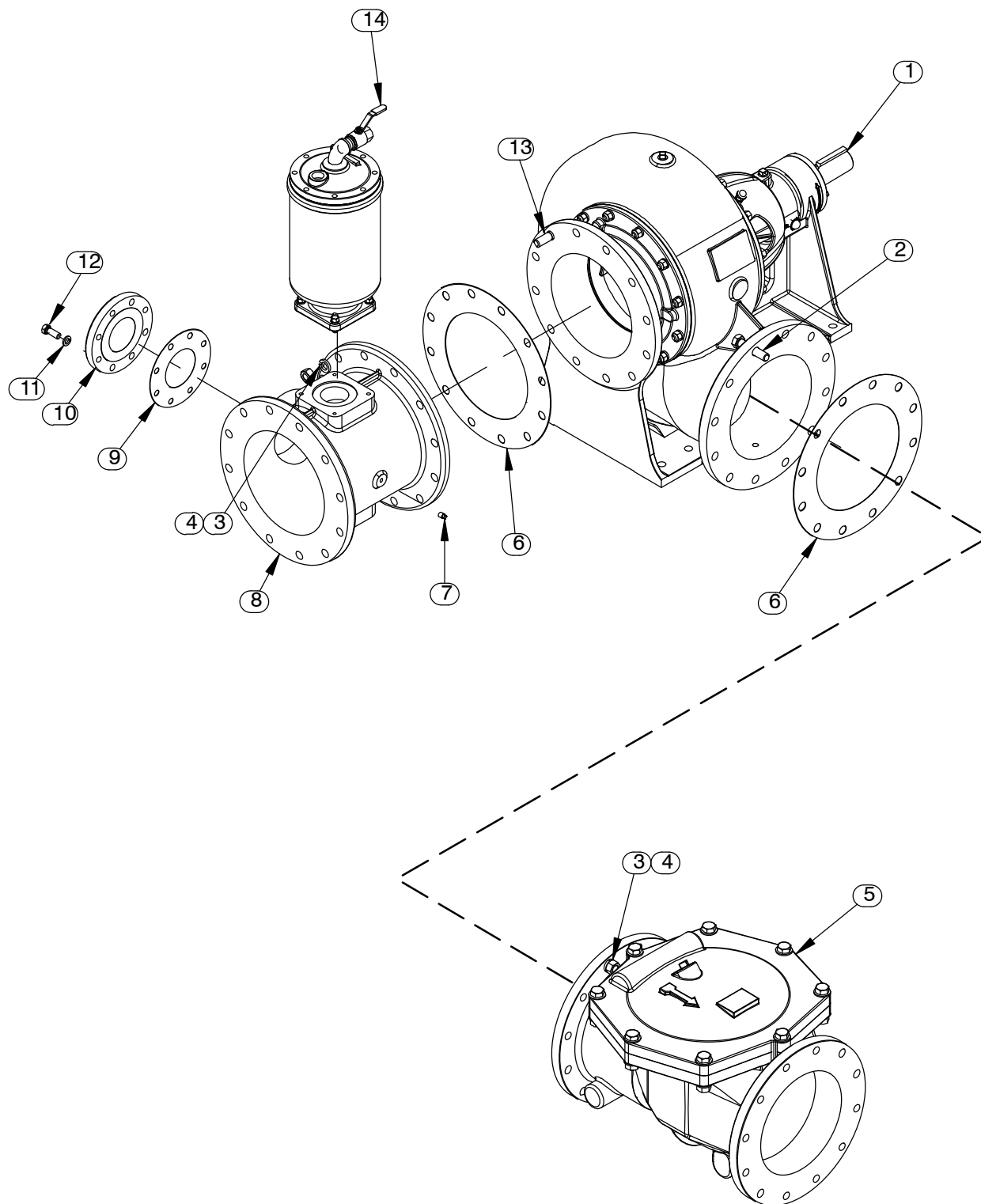

Figure 5. Pump Assembly

PARTS LIST
Pump Assembly

| ITEM NO. | PART NAME | PART NUMBER | QTY |
|-------------|--------------------------|-----------------|-----|
| 1 | PUMP | 46133-640 | 1 |
| 2 | HEX HEAD CAP SCREW | B1416 15991 | 12 |
| 3 | LOCK WASHER | J14 15991 | 24 |
| 4 | HEX NUT | D14 15991 | 24 |
| 5 | CHECK VALVE 12" | 26642-149 | 1 |
| | -FLAPPER | 26688-003 | 1 |
| | * -GASKET | 26688-004 | 1 |
| | * -O-RING | 25152-469 | 1 |
| 6 | * FLANGE GASKET | 4991G 18000 | 2 |
| 7 | PIPE PLUG | P04 15079 | 1 |
| 8 | 12" SPOOL | 38642-622 10000 | 1 |
| 9 | * BLIND FLANGE GASKET | 25113-034 | 1 |
| 10 | 4" BLIND FLANGE ASSEMBLY | 42111-358 | 1 |
| 11 | LOCK WASHER | J10 15991 | 8 |
| 12 | HEX HEAD CAP SCREW | B1007 15991 | 8 |
| 13 | HEX HEAD CAP SCREW | B1413 15991 | 12 |
| 14 | PRIMING CHAMBER KIT | 48275-006 | 1 |

* INDICATES PARTS RECOMMENDED FOR STOCK

ILLUSTRATION

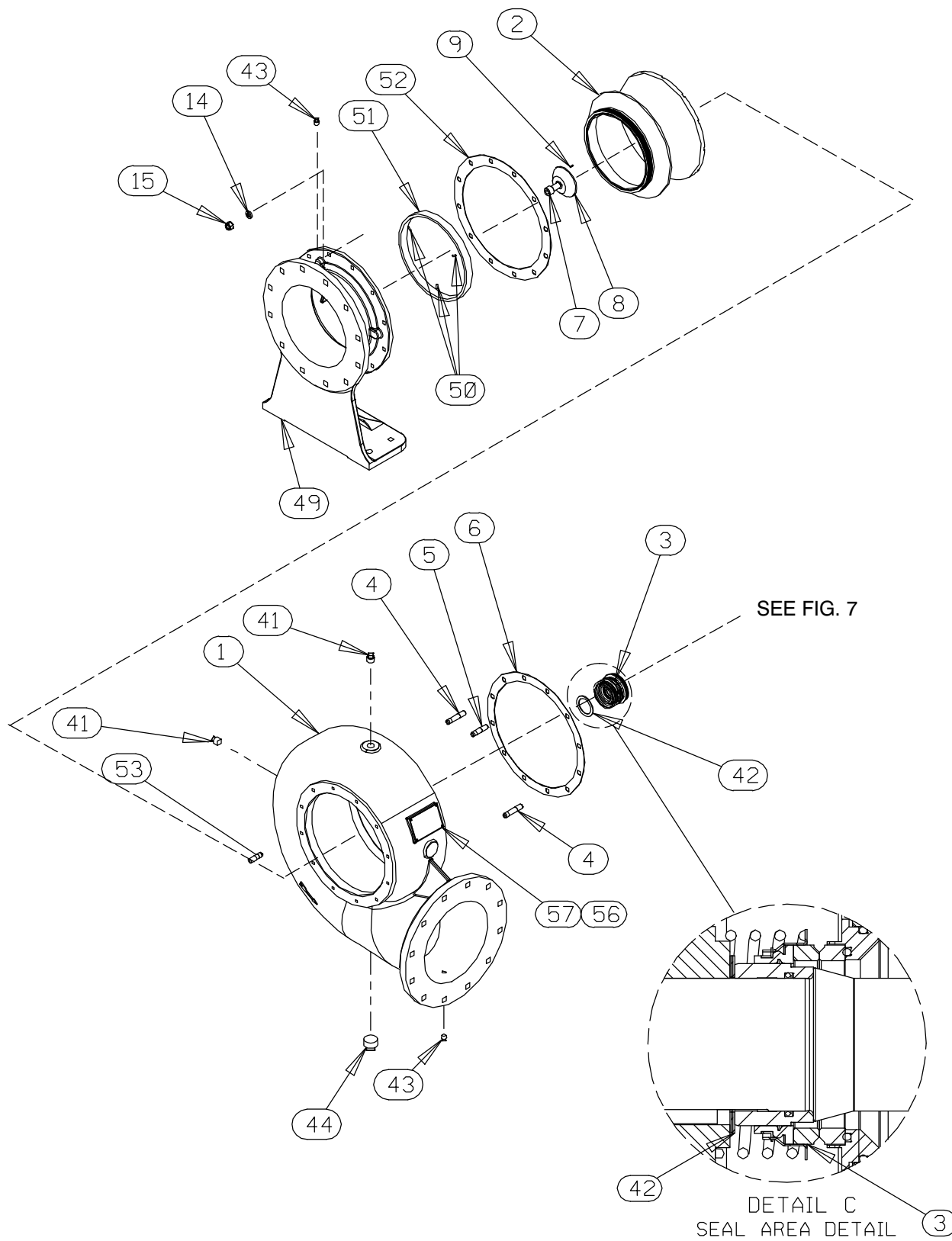

Figure 6. Pump End Assembly

PARTS LIST Pump End Assembly

| ITEM NO. | PART NAME | PART NUMBER | QTY | | ITEM NO. | PART NAME | PART NUMBER | QTY |
|----------|-----------------------|-----------------|-----|--|------------|----------------------|-----------------|-----|
| ☞ 1 | PUMP CASING | 38219-305 10010 | 1 | | 34 * | ROLLER BEARING | 23528-005 | 1 |
| 2 * | IMPELLER | 38621-809 11010 | 1 | | 35 | BEARING CAP | 38322-425 10010 | 1 |
| 3 * | SEAL ASSY | 46512-109 | 1 | | 36 | AIR VENT | S1703 | 1 |
| ☞ 4 | STUD | C1013 15991 | 3 | | 37 * | BEARING CAP O-RING | 25151-266 | 1 |
| ☞ 5 | STUD | C1011 15991 | 9 | | 38 | PIPE CPLG 3/8 | AE06 15079 | 1 |
| 6 * | GASKET | 38674-434 18000 | 1 | | 39 | PIPE NIPPLE | T0608 15079 | 1 |
| 7 * | SOCKET HD CAP SCREW | BD1206 15990 | 1 | | 40 | SEAL PLATE | 38272-717 10000 | 1 |
| 8 * | IMPELLER WASHER | 31167-012 15030 | 1 | | ☞ 41 | PIPE PLUG | P12 15079 | 2 |
| 9 * | ROLL PIN | S2197 | 1 | | 42 | IMP ADJ SHIM SET | 48261-033 | REF |
| 10 | HOSE CLAMP | 26518-642 | 2 | | 43 | PIPE PLUG | P06 15079 | 2 |
| 11 | MALE CONNECTOR | 26523-409 | 2 | | ☞ 44 | PIPE PLUG | P24 10009 | 1 |
| 12 | BTTLE OILER BRKT ASSY | 41881-811 24150 | 1 | | 45 | SEAL PLATE COVER | 38242-708 10000 | 1 |
| 13 | FLAT WASHER | K10 15991 | 1 | | 46 | HEX HEAD CAP SCREW | B0503-1/2 15991 | 6 |
| 14 | LOCK WASHER | J10 15991 | 22 | | 47 | LOCK WASHER | J05 15991 | 6 |
| 15 | HEX NUT | D10 15991 | 24 | | 48 | .38 ID x 11" LG HOSE | 18513-054 | 1 |
| 16 | MACHINE SCREW | X0405 15991 | 2 | | 49 | SUCTION HEAD | 4180 10010 | 1 |
| 17 | LOCK WASHER | J04 15991 | 2 | | 50 | SPIRAL PIN | 21137-123 | 3 |
| 18 | SIGHT GAUGE | S1471 | 2 | | 51 * | WEAR RING | 4181A 14000 | 1 |
| 19 | VENTED PIPE PLUG | 38649-009 15079 | 1 | | 52 * | GASKET | 4180G 18000 | 1 |
| 20 | PEDESTAL | 38257-520 10000 | 1 | | ☞ 53 | STUD | C1009 15991 | 12 |
| 21 | PIPE PLUG | P04 15079 | 1 | | 54 | BOTTLE OILER | 26713-004 | 1 |
| 22 | HEX HEAD CAP SCREW | B0605 15991 | 12 | | 55 | SNAP RING | 24124-057 | 1 |
| 23 * | OIL SEAL | 25258-845 | 3 | | 56 | DRIVE SCREW | BM#04-03 17000 | 4 |
| 24 | BEARING CAP | 38322-429 10000 | 1 | | 57 | NAMEPLATE BLANK | 38819-002 13000 | 1 |
| 25 * | O-RING | 25152-249 | 1 | | NOT SHOWN: | | | |
| 26 | SHIM SET | 48261-055 | 1 | | | SUCTION STICKER | 6588AG | 1 |
| 27 | BEARING LOCKNUT | 23962-015 | 1 | | | ROTATION DECAL | 2613M | 1 |
| 28 | BEARING LOCK WASHER | 23962-515 | 1 | | | G-R DECAL | GR-06 | 1 |
| 29 * | BEARING CAP GASKET | 4184G 18000 | 1 | | | WARNING DECAL | 2613FE | 1 |
| 30 * | BALL BEARING | 23413-015 | 2 | | | INSTRUCTION TAG | 38817-024 | 1 |
| 31 * | SHAFT KEY | N1016 15990 | 1 | | | LUBRICATION DECAL | 38816-079 | 1 |
| 32 * | IMPELLER SHAFT | 38512-522 17040 | 1 | | | INSTRUCTION TAG | 38817-011 | 1 |
| 33 * | IMPELLER KEY | N0809 15990 | 1 | | | OIL LEVEL DECAL | 38816-123 | 1 |
| | | | | | | DISCHARGE STICKER | 6588BJ | 1 |

* INDICATES PARTS RECOMMENDED FOR STOCK

☞ INCLUDED WITH REPAIR 46474-902 1
PUMP CASING ASSY

ILLUSTRATION

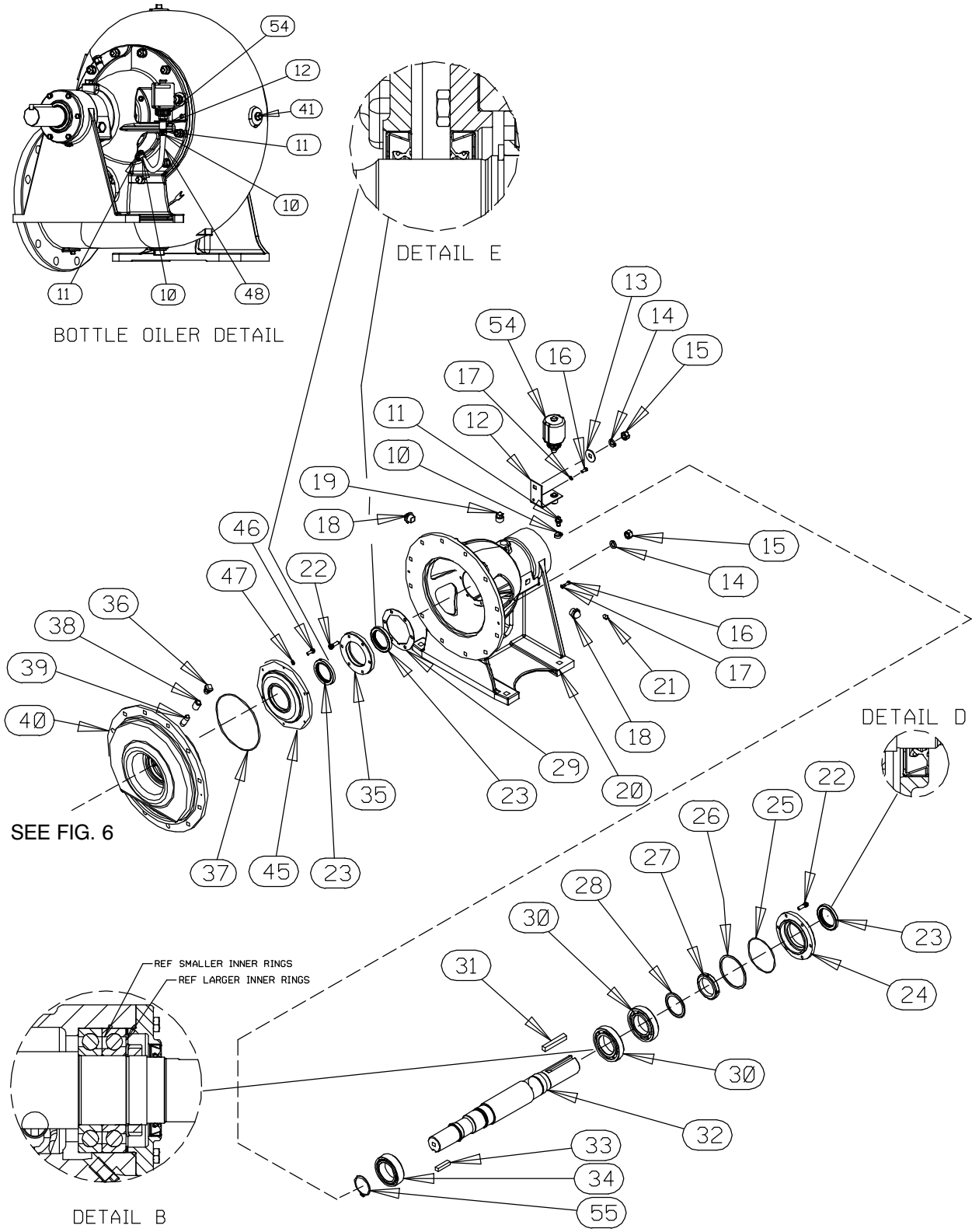

Figure 7. Pump End Assembly (Cont'd)

PARTS LIST

Pump End Assembly (Cont'd)

| ITEM NO. | PART NAME | PART NUMBER | QTY | ITEM NO. | PART NAME | PART NUMBER | QTY |
|----------|-----------------------|-----------------|-----|------------|----------------------|-----------------|-----|
| ☞ 1 | PUMP CASING | 38219-305 10010 | 1 | 34 * | ROLLER BEARING | 23528-005 | 1 |
| 2 * | IMP/WEAR RING ASSY | 46151-022 24110 | 1 | 35 | BEARING CAP | 38322-425 10010 | 1 |
| 3 * | SEAL ASSY | 46512-109 | 1 | 36 | AIR VENT | S1703 | 1 |
| ☞ 4 | STUD | C1013 15991 | 3 | 37 * | BEARING CAP O-RING | 25151-266 | 1 |
| ☞ 5 | STUD | C1011 15991 | 9 | 38 | PIPE CPLG 3/8 | AE06 15079 | 1 |
| 6 * | GASKET | 38674-434 18000 | 1 | 39 | PIPE NIPPLE | T0608 15079 | 1 |
| 7 * | SOCKET HD CAP SCREW | BD1206 15990 | 1 | 40 | SEAL PLATE | 38272-717 10000 | 1 |
| 8 * | IMPELLER WASHER | 31167-012 15030 | 1 | ☞41 | PIPE PLUG | P12 15079 | 2 |
| 9 * | ROLL PIN | S2197 | 1 | 42 | IMP ADJ SHIM SET | 48261-033 | REF |
| 10 | HOSE CLAMP | 26518-642 | 2 | 43 | PIPE PLUG | P06 15079 | 2 |
| 11 | MALE CONNECTOR | 26523-409 | 2 | ☞44 | PIPE PLUG | P24 10009 | 1 |
| 12 | BTTLE OILER BRKT ASSY | 41881-811 24150 | 1 | 45 | SEAL PLATE COVER | 38242-708 10000 | 1 |
| 13 | FLAT WASHER | K10 15991 | 1 | 46 | HEX HEAD CAP SCREW | B0503-1/2 15991 | 6 |
| 14 | LOCK WASHER | J10 15991 | 22 | 47 | LOCK WASHER | J05 15991 | 6 |
| 15 | HEX NUT | D10 15991 | 24 | 48 | .38 ID x 11" LG HOSE | 18513-054 | 1 |
| 16 | MACHINE SCREW | X0405 15991 | 2 | 49 | SUCTION HEAD | 4180 10010 | 1 |
| 17 | LOCK WASHER | J04 15991 | 2 | 50 | SPIRAL PIN | 21137-123 | 3 |
| 18 | SIGHT GAUGE | S1471 | 2 | 51 * | WEAR RING | 4181A 14000 | 1 |
| 19 | VENTED PIPE PLUG | 38649-009 15079 | 1 | 52 * | GASKET | 4180G 18000 | 1 |
| 20 | PEDESTAL | 38257-520 10000 | 1 | ☞53 | STUD | C1009 15991 | 12 |
| 21 | PIPE PLUG | P04 15079 | 1 | 54 | BOTTLE OILER | 26713-004 | 1 |
| 22 | HEX HEAD CAP SCREW | B0605 15991 | 12 | 55 | SNAP RING | 24124-057 | 1 |
| 23 * | OIL SEAL | 25258-845 | 3 | 56 | DRIVE SCREW | BM#04-03 17000 | 4 |
| 24 | BEARING CAP | 38322-429 10000 | 1 | 57 | NAMEPLATE BLANK | 38819-002 13000 | 1 |
| 25 * | O-RING | 25152-249 | 1 | NOT SHOWN: | | | |
| 26 | SHIM SET | 48261-055 | 1 | | SUCTION STICKER | 6588AG | 1 |
| 27 | BEARING LOCKNUT | 23962-015 | 1 | | ROTATION DECAL | 2613M | 1 |
| 28 | BEARING LOCK WASHER | 23962-515 | 1 | | G-R DECAL | GR-06 | 1 |
| 29 * | BEARING CAP GASKET | 4184G 18000 | 1 | | WARNING DECAL | 2613FE | 1 |
| 30 * | BALL BEARING | 23413-015 | 2 | | INSTRUCTION TAG | 38817-024 | 1 |
| 31 * | SHAFT KEY | N1016 15990 | 1 | | LUBRICATION DECAL | 38816-079 | 1 |
| 32 * | IMPELLER SHAFT | 38512-522 17040 | 1 | | INSTRUCTION TAG | 38817-011 | 1 |
| 33 * | IMPELLER KEY | N0809 15990 | 1 | | OIL LEVEL DECAL | 38816-123 | 1 |
| | | | | | DISCHARGE STICKER | 6588BJ | 1 |

* INDICATES PARTS RECOMMENDED FOR STOCK

☞ INCLUDED WITH REPAIR 46474-902 1
PUMP CASING ASSY

ILLUSTRATION

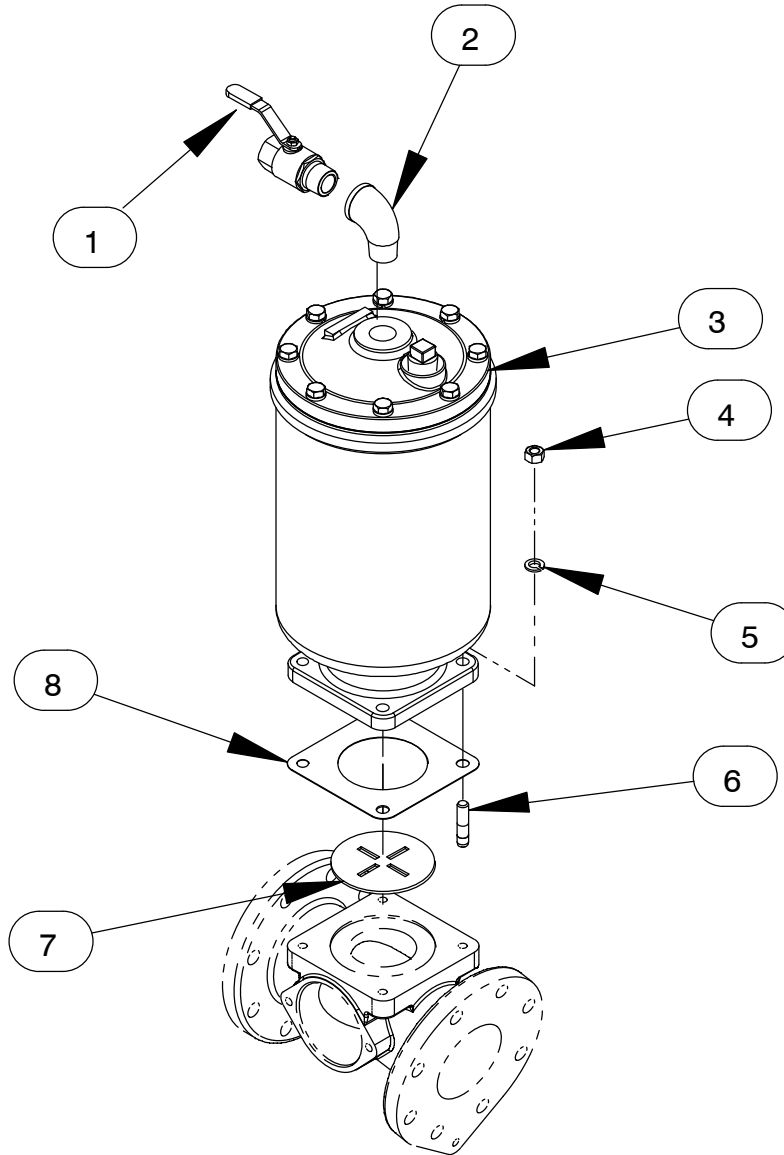

Figure 8. Priming Chamber Kit

| ITEM NO. | PART NAME | PART NUMBER | QTY |
|----------|--------------------------|-----------------|-----|
| 1 | BALL VALVE | 26631-054 | 1 |
| 2 | STREET ELBOW | RS16 11999 | 1 |
| 3 | PRIMING CHAMBER ASSEMBLY | 46112-709 | 1 |
| 4 | HEX NUT | D08 15991 | 4 |
| 5 | LOCK WASHER | J08 15991 | 4 |
| 6 | STUD | C0809 15991 | 4 |
| 7 | BAFFLE | 31113-011 17000 | 1 |
| 8 | * GASKET | 38687-053 19060 | 1 |

* INDICATES PARTS RECOMMENDED FOR STOCK

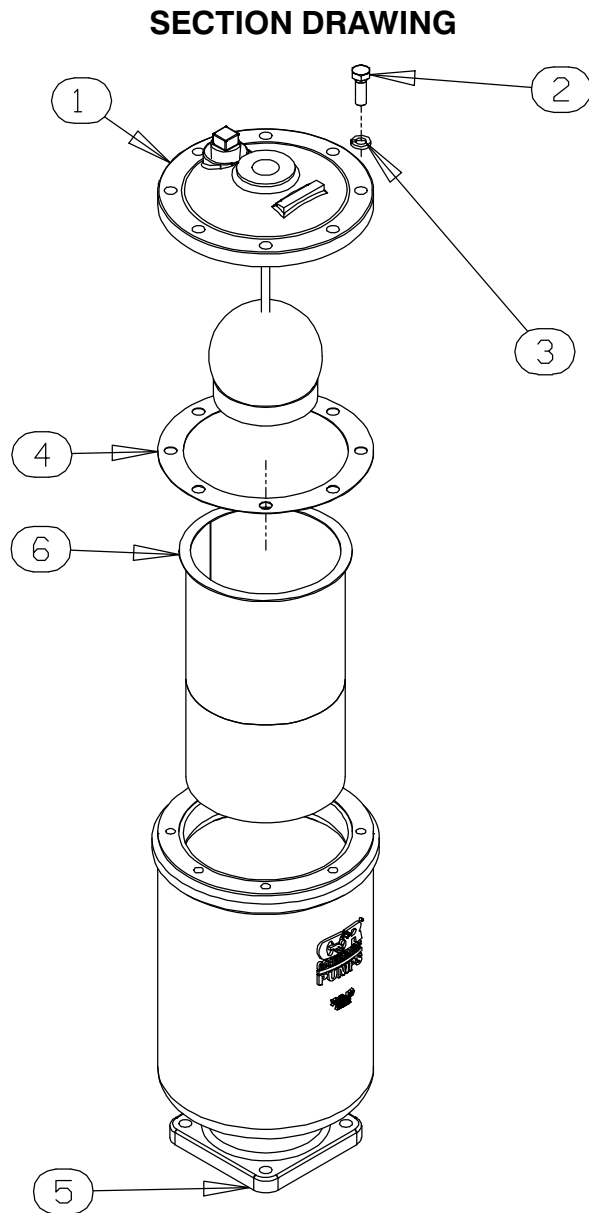

Figure 9. Priming Chamber Assembly

| ITEM NO. | PART NAME | PART NUMBER | QTY |
|----------|----------------------------------|------------------------|----------|
| 1 | PRIMING VALVE -ORIFICE BUTTON | 26664-007 26688-021 | 1 REF |
| 2 | HEX HEAD CAP SCREW | B0806 15991 | 8 |
| 3 | LOCK WASHER | J08 15991 | 8 |
| 4 | * PRIMING VALVE GASKET | 38683-657 19060 | 1 |
| 5 | PRIMING CHAMBER | 38343-020 10000 | 1 |
| 6 | STRAINER ASSEMBLY | 46641-222 17000 | 1 |

* INDICATES PARTS RECOMMENDED FOR STOCK

ILLUSTRATION

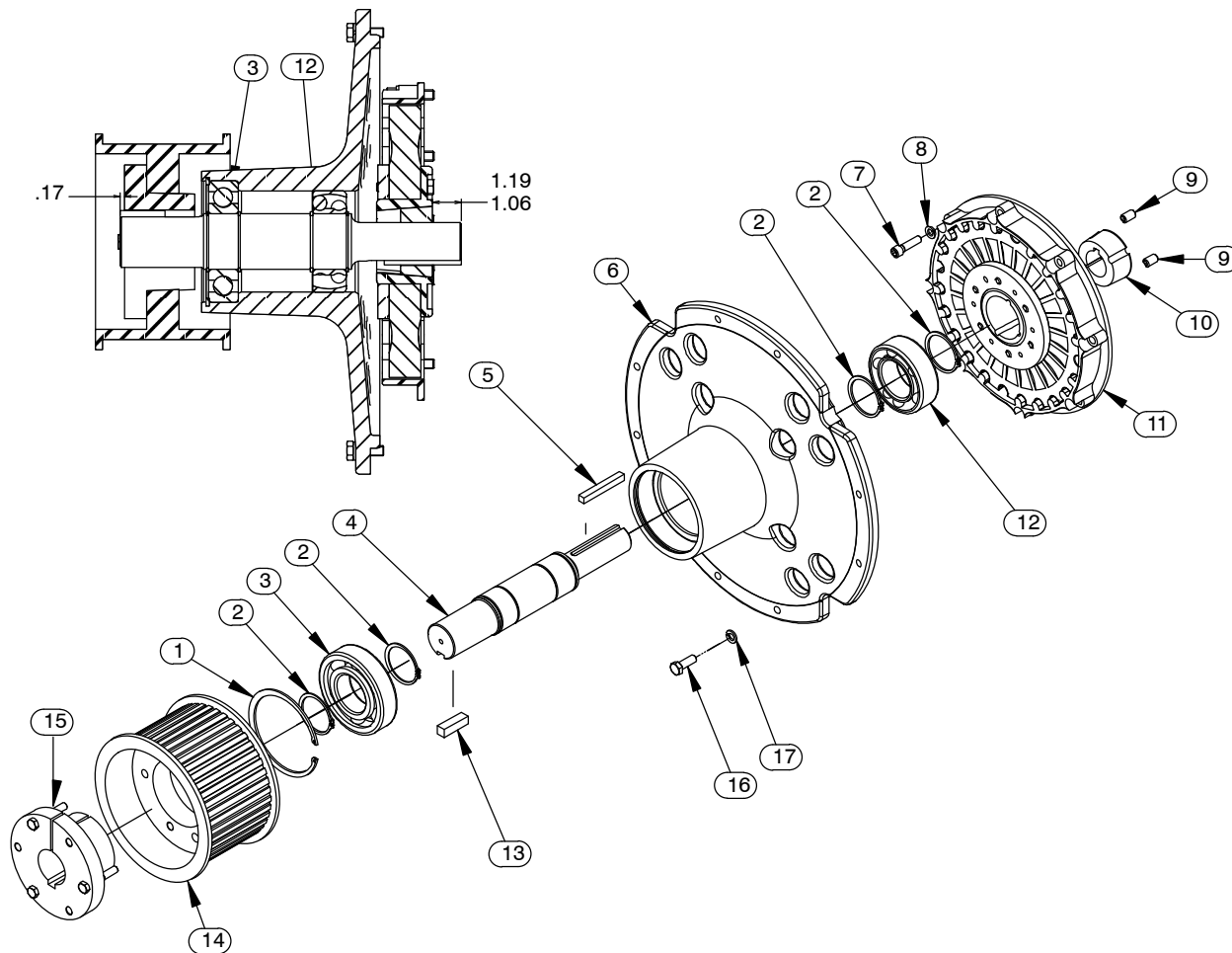

Figure 10. Engine Drive Assembly

| ITEM NO. | PART NAME | PART NUMBER | QTY |
|----------|--------------------------|-------------------|-----|
| 1 | RETAINING RING | 24121-075 | 1 |
| 2 | RETAINING RING | S215 | 4 |
| 3 | * BALL BEARING | 23282-012 | 1 |
| 4 | * OUTPUT SHAFT | 38512-051 1706H | 1 |
| 5 | * KEY | N0612 15990 | 1 |
| 6 | BEARING HOUSING | 38251-001 11010 | 1 |
| 7 | SOCKET HEAD CAP SCREW | BD0606-1/2S 15990 | 8 |
| 8 | LOCK WASHER | J06 15991 | 8 |
| 9 | ALLEN HD SET SCREW | GA0703-1/2 15990 | REF |
| 10 | BUSHING 2012 X 1-1/2 | 24131-496 | 1 |
| 11 | COUPLING W/O BUSHING | 24391-103 | 1 |
| 12 | * BALL BEARING | 23431-012 | 1 |
| 13 | * KEY | N0807 15990 | 1 |
| 14 | SPROCKET | 24271-004 | 1 |
| 15 | TAPERLOCK BUSHING | 24131-526 | 1 |
| 16 | CAP SCREW M10 X 1.5 X 30 | 22645-164 | 8 |
| 17 | LOCK WASHER M10 | 21171-511 | 8 |

* INDICATES PARTS RECOMMENDED FOR STOCK

PUMP AND SEAL DISASSEMBLY AND REASSEMBLY

Review all SAFETY information in Section A.

Follow the instructions on all tags, label and decals attached to the pump.

This pump requires little service due to its rugged, minimum-maintenance design. However, if it becomes necessary to inspect or replace the wearing parts, follow these instructions which are keyed to the illustrations (see Figures 1 through 10) and the accompanying parts list.



This manual will alert personnel to known procedures which require special attention, to those which could damage equipment, and to those which could be dangerous to personnel. However, this manual cannot possibly anticipate and provide detailed instructions and precautions for every situation that might occur during maintenance of the unit. Therefore, it is the responsibility of the owner/maintenance personnel to ensure that only safe, established maintenance procedures are used, and that any procedures not addressed in this manual are performed only after establishing that neither personal safety nor pump integrity are compromised by such practices.

Before attempting to service the pump, shut down the engine and take precautions to ensure that the pump will remain inoperative. Close all valves in the suction and discharge lines.

For engine disassembly and repair, consult the literature supplied with the engine, or contact your local engine representative.



Before attempting to open or service the pump:

1. Familiarize yourself with this manual.
2. Shut down the engine and disconnect the positive battery cable to ensure that the pump will remain inoperative.
3. Allow the pump to completely cool if overheated.
4. Check the temperature before opening any covers, plates, or plugs.
5. Close the suction and discharge valves.
6. Vent the pump slowly and cautiously.
7. Drain the pump.



This pump may be used to handle materials which could cause illness through direct exposure or emitted fumes. Wear adequate protective clothing when working on the pump or piping.



Death or serious personal injury and damage to the pump or components can occur if proper lifting procedures are not observed. Make certain that hoists, chains, slings or cables are in good working condition and of sufficient capacity and that they are positioned so that loads will be balanced and the pump or components will not be damaged when lifting. Suction and discharge hoses and piping must be removed from the pump before lifting. Lift

the pump or component only as high as necessary and keep personnel away from suspended objects.



Use **Only Genuine Gorman—Rupp** replacement parts. Failure to do so may create a hazard and damage the pump or diminish optimal pump performance. Any such hazard, damage or diminished performance is not covered by the warranty.

NOTE

When appropriate recycling facilities are available, the user should recycle components and fluids when doing any routine maintenance / repairs and also at the end of the pump's useful life. All other components and fluids shall be disposed of according to all applicable codes and regulations.

Priming Chamber Removal And Disassembly

(Figure 8)

Disconnect both the suction piping and the air discharge tubing from the priming chamber assembly (3). Support the priming chamber assembly using a sling and a suitable lifting device. Disengage the hardware (4 and 5) and separate the priming chamber assembly, gasket (8) and baffle (7) from the spool (8, Figure 5).

(Figure 9)

Remove the hardware (2 and 3) securing the priming valve (1) to the priming chamber (5). Carefully lift the valve components from the priming chamber. Remove the gasket (4) and clean the mating surfaces.

If the priming chamber float is stuck or the strainer (6) is clogged, it can usually be cleaned without further disassembly.

The only serviceable part of the priming chamber is the orifice button (not shown). If liquid continues to bypass through the priming chamber after adjusting the orifice button (see **Priming Chamber Reassembly and Installation** for adjustment), the button may require replacement. To replace the

orifice button, remove one of the “e-clips” from the pivot pin closest to the orifice button and remove the pivot pin. This will allow the linkage to be raised high enough to access the orifice button.

Remove the hex nut and lockwasher securing the orifice button to the linkage bar and unscrew the orifice button from the linkage bar.

Discharge Check Valve Removal and Disassembly

(Figure 5)

Support the discharge check valve assembly (5) using a sling and a suitable lifting device. Remove the hardware (3 and 4) and separate the discharge check valve assembly and gasket (6) from the pump assembly (1).

The flapper and cover gasket are the only serviceable parts of the check valve. If the flapper requires replacement, remove the hardware securing the cover. Separate the valve cap and remove the flapper and gasket.

Suction Head And Wear Ring Removal

(Figure 6)

Unless replacement of the spool gasket (6, Figure 5) is required, the suction head (49) may be removed without separating it from the spool. However, if the spool gasket must be replaced, support the spool with a suitable hoist and sling, remove the hardware (3 and 4, Figure 5) and separate the suction spool and gasket from the suction head.

Remove the hardware securing the suction head (49) to the base. Support the suction head using a suitable hoist and sling. Disengage the hardware (14 and 15) and separate the suction head and wear ring (51) from the pump casing. Remove the suction head gasket (52) and clean the mating surfaces.

Inspect the wear ring for excessive wear or scoring. The wear ring is a press fit into the suction head and is additionally secured with the spiral pins (50). If replacement is required, use a small bit to drill three holes horizontally, 180° apart, through the wear ring between each of the spiral pins. Use a chisel or other suitable tool to complete the cuts through the wear ring. **Use caution** not to damage

the suction head bore. Remove the wear ring sections from the suction head. Pull the spiral pins from the suction head.

If no further disassembly is required, see **Suction Head and Wear Ring Installation**.

Pump Casing Removal

(Figure 6)

Support the pump casing using a suitable hoist and sling.

NOTE

When removing the pump casing, use a wire to secure the assembled bottle oiler (54, Figure 7) and bracket (12, Figure 7) above the level of the oil in the seal cavity. This will prevent oil from leaking out of the oiler during disassembly.

If the impeller (2) is to be removed, the impeller screw (7) should be loosened before removing the pump casing. Immobilize the impeller by inserting a wood block through the pump discharge and into the impeller vanes. Remove the impeller screw and washer (8). Remove the wood block from the pump discharge.

Remove the hardware (13, 14 and 15, Figure 7) securing the pump casing and bottle oiler bracket to the pedestal (20, Figure 7).

Pull the pump casing straight away from the pedestal to prevent binding on the impeller. Remove the casing gasket (6) and clean the contacting surfaces.

Impeller Removal

(Figure 6)

Before removing the impeller, loosen the hose clamp (10, Figure 7) and remove the hose (48, Figure 7) from the lower connector (11, Figure 7). Remove the bottle oiler and bracket assembly and drain the seal cavity. This will prevent the oil in the oiler from escaping when the impeller is removed.

With the impeller screw and washer removed as described in **Pump Casing Removal**, insert a pair of wedges 180° apart between the impeller and the

seal plate (40, Figure 7). Tap the wedges alternately to force the impeller off the shaft. Retain the impeller key (33, Figure 7).

Inspect the impeller wear ring for excessive wear or scoring.

Seal Removal

(Figures 6 and 12)

This pump is designed with two seals; a primary mechanical seal (3) located directly behind the impeller and a secondary oil seal (23) located in the seal plate cover (45). If the liquid being pumped leaks past the oil seal, both seals should be replaced immediately.

Remove the impeller shims (42). Tie and tag the shims for ease of reassembly. Remove the seal spring. Slide the rotating portion of the seal (consisting of the shaft sleeve and O-ring, bellows and retainer, and rotating element) off the shaft as a unit.

Apply oil to the sleeve and work it up under the rubber bellows. Slide the bellows and retainer off the sleeve. Remove the sleeve O-ring.

Slide the seal plate and remaining seal components off the shaft. Disengage the hardware (46 and 47, Figure 7) and separate the seal plate cover and O-ring (37, Figure 7) from the seal plate.

Use a suitably sized dowel to press the stationary portion of the seal out of the seal plate. Press the oil seal out of the seal plate cover.

If no further disassembly is required, refer to **Seal Installation**.

Pedestal Assembly Removal

(Figure 2)

Disassembly of the pedestal requires separation of the pump and driver. Disengage the hardware securing the belt guard to the lifting bail and remove the guard.

Loosen, but do not remove, the hardware securing the pump suction head (49, Figure 6) and pedestal (20, Figure 7) to the fuel tank assembly (19).

Tension on the pump drive belt (56) is obtained through the use of “pusher rods” used to move the

pump and pedestal side-to-side. To remove the pedestal, loosen the outer hardware on the threaded rods. Unscrew the jam nuts until they engage the adjusting brackets. Continue to unscrew the jam nuts in an alternating sequence to “push” the pedestal assembly toward the pump sprocket (58). When sufficient clearance is obtained, remove the pump drive belt from the engine sprocket (14, Figure 10).

Remove the hardware securing the pedestal to the base. Use a suitable hoist and sling to remove the pedestal assembly.

Pump Shaft and Bearing Removal and Disassembly

(Figure 2)

When the pump is properly operated and maintained, the pedestal should not require disassembly. Disassemble the shaft and bearings **only** when there is evidence of wear or damage.



Shaft and bearing disassembly in the field is not recommended. These operations should be performed only in a properly equipped shop by qualified personnel.

The sprocket and bushing (57 and 58) must be removed from the drive end of the shaft before disassembling the pedestal (20, Figure 7). To remove the sprocket, remove the screws securing the sprocket to the hub, then reinstall the screws in the tapped holes in the sprocket. Tighten the screws in an alternating sequence to press against the hub shoulder and “jack” the sprocket off the hub.

With the sprocket removed, the hub can be pulled or pried off the shaft. Remove the shaft key.

(Figure 7)

Before disassembling the pedestal, remove the pedestal drain plug (21) and drain the oil from the pedestal. Clean and reinstall the pipe plug.

Disengage the capscrews (22) and remove the outboard bearing cap (24), O-ring (25) and oil seal (23). Remove the bearing shims (26). Press the oil seal from the bearing cap.

Straighten the tab on the washer (28) securing the bearing lock nut (27). Use a spanner wrench to remove the lock nut. Remove the tab washer.

Disengage the capscrews (22) and remove the inboard bearing cap (35) and oil seal (23). Remove the bearing cap gasket (29) and clean the mating surfaces. Press the oil seal from the bearing cap.

Place a block of wood against the impeller end of the shaft (32) and tap the shaft and assembled bearings (30 and 34) out of the pedestal.

After removing the shaft and bearings, clean and inspect the bearings **in place** as described in **Bearing Cleaning And Inspection**.

The bearing tolerances provide a tight press fit onto the shaft and a snug slip fit into the pedestal. Replace the bearings, shaft, or pedestal if the proper bearing fit is not achieved.

If bearing replacement is required, remove the retaining ring (55) and use a bearing puller to remove the inboard and outboard bearings from the shaft.

Engine Drive Disassembly

(Figure 10)

This engine is equipped with a jackshaft type drive assembly as shown in Figure 10.

To remove the sprocket (14), remove the capscrews securing the taperlock bushing (15) to the sprocket. Reinstall the capscrews in the tapped holes in the bushing and use a suitable puller to pull the bushing and sprocket off the output shaft (4). Retain the key (13).

Further disassembly requires separating the remaining drive components from the engine. Remove the hardware (not shown, supplied with the engine) securing the bearing housing (16) to the engine. Pull the shaft and bearing housing straight away from the engine. The rubber drive element of the coupling (11) will separate from the drive ring secured to the engine flywheel with the hardware (7 and 8). Disengage the hardware to remove the drive ring from the flywheel.

To remove the flexible portion of the coupling from the output shaft, unscrew the two allen head setscrews (9) from the bushing (10). Screw one of the setscrews into the hole on the circumference of the

bushing to separate the coupling and bushing. When the parts separate, remove the bushing, and slide the coupling off the shaft. Remove the key (5).

When properly operated and maintained, the output shaft and bearings should not require disassembly. Disassemble the shaft and bearings **only** when there is evidence of wear or damage.



Shaft and bearing disassembly in the field is not recommended. These operations should be performed only in a properly equipped shop by qualified personnel.

To remove the shaft and bearings (3 and 12), use snap ring pliers to remove the retaining ring (1). Use a wood block to tap the shaft and bearings from the bearing housing from the driven end.

After removing the shaft and bearings, clean and inspect the bearings **in place** as described in **Bearing Cleaning And Inspection**.



To prevent damage during removal from the shaft, it is recommended that bearings be cleaned and inspected **in place**. It is **strongly** recommended that the bearings be replaced **any** time the shaft and bearings are removed.

The bearing tolerances provide a tight press fit onto the shaft and a snug slip fit into the bearing housing. Replace the bearings, shaft, or bearing housing if the proper bearing fit is not achieved.

If bearing replacement is required, remove the outboard retaining rings (2) and use a bearing puller to remove the inboard (3) and outboard (12) bearings from the shaft.

It is not necessary to remove the inboard bearing retaining rings unless replacement is required. Use snap ring pliers to remove the retaining rings as required.

Bearing Cleaning And Inspection

(Figure 7)

Clean the pedestal, bearing housing, shafts and all component parts (except the bearings) with a soft cloth soaked in cleaning solvent. Inspect the parts for wear or damage and replace as necessary.



Most cleaning solvents are toxic and flammable. Use them only in a well ventilated area free from excessive heat, sparks, and flame. Read and follow all precautions printed on solvent containers.

Clean the bearings thoroughly in **fresh** cleaning solvent. Dry the bearings with filtered compressed air and coat with light oil.



Bearings must be kept free of all dirt and foreign material. Failure to do so will greatly shorten bearing life. **Do not** spin dry bearings. This may scratch the balls or races and cause premature bearing failure.

Rotate the bearings by hand to check for roughness or binding. Inspect the bearing balls (or rollers) on open-type bearings. If rotation is rough or the balls or rollers are discolored, replace the bearings.

Engine Drive Reassembly

(Figure 10)

Inspect the output shaft for distortion, nicks, scratches, damaged keyways or galling on the bearing seating surfaces. Dress small nicks and burrs with a fine file or emery cloth. Replace the shaft if defective.

If removed, install the inboard bearing retaining rings (2) on the output shaft (4).



CAUTION

To prevent damage during removal from the shaft, it is recommended that bearings be cleaned and inspected **in place**. It is **strongly** recommended that the bearings be replaced **any** time the shaft and bearings are removed.

The bearings may be heated to ease installation. An induction heater, hot oil bath, electric oven, or hot plate may be used to heat the bearings. Bearings should **never** be heated with a direct flame or directly on a hot plate.

NOTE

*If a hot oil bath is used to heat the bearings, both the oil and the container must be **absolutely** clean. If the oil has been previously used, it must be **thoroughly** filtered.*

Heat the bearings to a uniform temperature **no higher than** 250°F (120°C), and slide the bearings onto the shaft, one at a time, until they are fully seated. This should be done quickly, in one continuous motion, to prevent the bearings from cooling and sticking on the shaft.



CAUTION

Use caution when handling hot bearings to prevent burns.

After the bearings have been installed and allowed to cool, check to ensure that they have not moved in shrinking. If movement has occurred, use a suitably sized sleeve and a press to reposition the bearings.

If heating the bearings is not practical, use a suitably sized sleeve and an arbor (or hydraulic) press to install the bearings on the shaft.

Slide the shaft and assembled bearings into the bearing housing until the outboard bearing is fully seated against the bearing housing shoulder.



CAUTION

When installing the shaft and bearings into the bearing bore, push against the outer race. **Never** hit the balls or ball cage.

Secure the shaft and bearings in the bearing housing with the bearing retaining ring (1).

Install the key (5) in the output shaft keyway. Position the flexible portion of the coupling assembly (3) on the shaft as shown in Figure 10.

NOTE

*The flexible portion of the coupling must be properly positioned on the shaft. The heads of the capscrews in the center of the coupling **must be positioned toward the drive end of the shaft.***

Align the keyway in the bushing (10) with the shaft key, and slide the bushing onto the shaft. Rotate the flexible portion of the coupling until the tapped holes for the two setscrews align with those in the bushing and install the setscrews. Position the coupling to the dimension shown in Figure 10.



CAUTION

Make certain that the flexible portion of the coupling is mounted as shown in Figure 10. The end of the shaft must protrude 1.06 to 1.19 inches (26,9 to 30,2 mm) from the face of the bushing. **This dimension is critical.** If the coupling is not properly positioned on the shaft, the coupling parts may not fully engage, or a pre-load condition can cause premature bearing failure.

With the flexible portion of the coupling and the bushing properly positioned on the shaft, tighten the two setscrews in an alternating sequence until the bushing and coupling are fully secured. Torque the setscrews to 23 ft. lbs. (280 in. lbs. or 3,2 m. kg.) maximum.

Position the key (13) in the shaft keyway. Position the drive sprocket over the shaft. Align the keyway in the taperlock bushing (15) with the shaft key and slide the bushing onto the shaft. Align the holes in

the bushing with those in the sprocket, and install the bushing capscrews.

Position the sprocket on the shaft to the dimension shown in Figure 9 and tighten the bushing capscrews in an alternating sequence until the bushing and coupling are fully secured. Torque the setscrews to 60 ft. lbs. (720 in. lbs. or 8.3 m. kg.).

If the complete coupling assembly is being replaced, apply 'Loctite Retaining Compound No. 242' or equivalent compound to the threads of the hardware (7 and 9), and secure the outer ring of the coupling to the engine flywheel by torquing the hardware to 45 ft. lbs. (540 in. lbs. or 6,2 m. kg.).

Position the drive assembly so the flexible portion of the coupling seats inside the drive ring attached to the engine flywheel. Secure the bearing housing (6) to the engine bellhousing with the previously removed hardware.

NOTE

To ease installation, **lightly** lubricate the rubber portion of the coupling with a **non-petroleum based lubricant** such as vegetable oil or glycerin, or a silicon-based lubricant such as "WD40" or equivalent. **Do not** use petroleum-based lubricants, or any other substance which may soften or otherwise damage the rubber.

Pump Shaft and Bearing Reassembly and Installation

(Figure 7)

Inspect the impeller shaft (32) for distortion, nicks or scratches, or damaged keyways. Dress small nicks and burrs with a fine file or emery cloth. Replace the shaft if defective.



To prevent damage during removal from the shaft, it is recommended that bearings be cleaned and inspected **in place**. It is **strongly** recommended that the bearings be replaced **any** time the shaft and bearings are removed.

The bearings may be heated to ease installation. An induction heater, hot oil bath, electric oven, or hot plate may be used to heat the bearings. Bearings should **never** be heated with a direct flame or directly on a hot plate.

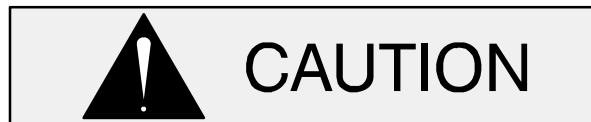

Use caution when handling hot bearings to prevent burns.

NOTE

If a hot oil bath is used to heat the bearings, both the oil and the container must be **absolutely** clean. If the oil has been previously used, it must be **thoroughly** filtered.

Heat the bearings to a uniform temperature **no higher than** 250°F (120°C). Position the roller bearing (34) on the shaft with the internal snap ring positioned away from the impeller end of the shaft. Slide the roller bearing onto the shaft until fully seated against the shaft shoulder. This should be done quickly, in one continuous motion, to prevent the bearings from cooling and sticking on the shaft.

After the bearing has been installed and allowed to cool, check to ensure that it has not moved away from the shaft shoulder in shrinking. If movement has occurred, use a suitably sized sleeve and a press to reposition the bearing against the shaft shoulder.

Secure the roller bearing on the shaft with the bearing retaining ring (55).

Slide the heated outboard bearings (30) onto the shaft, one at a time, with the larger inner races of each bearing positioned away from each other as shown in Figure 7.

If heating the bearings is not practical, use a suitably sized sleeve and an arbor (or hydraulic) press to install the bearings on the shaft.



When installing the bearings onto the shaft, **never** press or hit against the outer race, balls, or ball cage. Press **only** on the inner race.

After the bearings have been installed and allowed to cool, check to ensure that they have not moved away from the shaft shoulders in shrinking. If movement has occurred, use a suitably sized sleeve and a press to reposition the bearings against the shaft shoulder.

Secure the assembled shaft and bearings by clamping on the surface between the bearings. Use caution not to scratch or mar the part number etched into the shaft in this area. Install the tab washer (28) and bearing lock nut (27). Torque the lock nut to 150 ft. lbs. (1800 in. lbs. or 20,7 m. kg.). Locate the tab on the lockwasher that aligns with a slot in the lock nut, and bend the tab over into the slot.

Slide the shaft and assembled bearings into the pedestal from the drive end until the retaining in-board bearing (30) seats against the pedestal bore.



When installing the shaft and bearings into the bearing bore, push against the outer race. **Never** hit the balls or ball cage.

Press the oil seal (23) into the bearing cap (24) with the lip positioned as shown in Figure 7. Lubricate and install a new bearing cap O-ring (25) and secure the bearing cap with the capscrews (22). Use caution not to cut or roll the lip of the oil seal when installing the bearing cap.

Press the oil seal (23) into the bearing cap (35) with the lip positioned as shown in Figure 7. Replace the bearing cap gasket (29) and secure the bearing cap with the capscrews (22). Use caution not to cut or roll the lip of the oil seal when installing the bearing cap.

Lubricate the pedestal as indicated in **LUBRICATION**.

Install the sprocket and hub onto the impeller shaft as follows.

(Figures 7 and 11)

Install the key (31) in the shaft keyway. Align the keyway in the hub with the shaft key, and slide the

hub onto the shaft with the shoulder positioned toward the pedestal.

Slide the sprocket over the hub, align the mounting screw holes and install the mounting screws.

Position the hub and sprocket to the dimensions shown in Figure 11 and torque the mounting capscrews to 75 ft. lbs. (900 in. lbs. or 10.4 m. kg.)

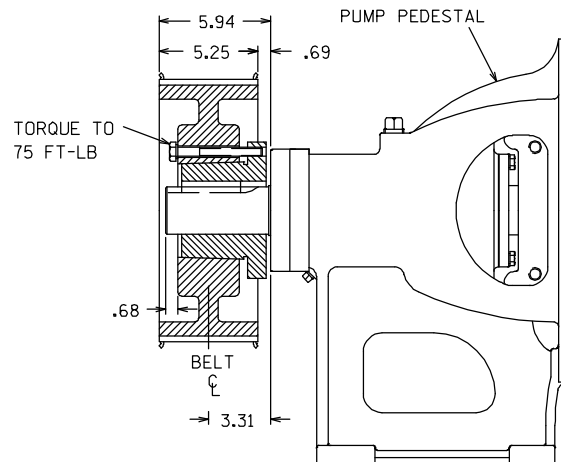

Figure 11. Hub and Sprocket Installation



Make certain that the hub and sprocket are mounted as shown in Figure 11. **This is critical.** If the sprocket is not properly positioned on the shaft, the pump drive belt will not be properly aligned, which can cause premature belt or bearing failure.

Pedestal Assembly Installation

(Figure 2)

Use a suitable hoist and sling to position the pedestal assembly on the base. Secure the pedestal to the base using the previously removed hardware.

Install the pump drive belt (56, Figure 2) after assembling the remaining pump components.

To adjust the drive belt tension, find the center of the belt span between the pump and engine sprockets. Use a belt deflection gauge to measure deflection **across the width of the belt** at this point. Use the “pusher rods” to adjust belt tension

to 3/8 inch (9,5 mm) of deflection at 30 lbs. (13,6 kg.) of pressure. **Do not** over-tighten the drive belt.

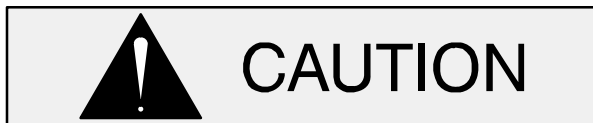

The inner edge of the pump pulley must be aligned with the outer edge of the drive pulley in order to prevent side wear of the cog belt.

Do not over-tighten the drive belt. Over-tightening will cause premature belt and/or bearing failure.

After tensioning, secure the pedestal by tightening the jam nuts and remaining hardware on the “pusher rods”.

Seal Reassembly and Installation

(Figures 6, 7 and 12)

Clean the bore of the seal plate (40), the seal plate cover (45) and the shaft (32) with a cloth soaked in fresh cleaning solvent.



Most cleaning solvents are toxic and flammable. Use them only in a well ventilated area free from excessive heat, sparks, and flame. Read and follow all precautions printed on solvent containers.

Lay the seal plate cover on a flat surface with the inner side facing up. Press the oil seal (23) into the seal plate cover with the lip positioned as shown in Detail E, Figure 7.

Install a new O-ring (37) in the groove in the seal plate and secure the seal plate cover to the seal plate with the hardware (46 and 47).

Since the mechanical seal is the primary seal in the pump, special consideration should be given to ensure proper installation.

The seal is not normally reused because wear patterns on the finished faces cannot be realigned during reassembly. This could result in premature failure. If necessary to reuse an old seal in an emergency, **carefully** wash all metallic parts in fresh cleaning solvent and allow to dry thoroughly.

Handle the seal parts with extreme care to prevent damage. Be careful not to contaminate precision finished faces; even fingerprints on the faces can shorten seal life. If necessary, clean the faces with a non-oil based solvent and a clean, lint-free tissue. Wipe **lightly** in a concentric pattern to avoid scratching the faces.

Inspect the seal components for wear, scoring, grooves, and other damage that might cause leakage. Clean and polish the shaft sleeve, or replace it if there are nicks or cuts on either end. If any components are worn, replace the complete seal; **never mix old and new seal parts.**

If a replacement seal is being used, remove it from the container and inspect the precision finished faces to ensure that they are free of any foreign matter.

To ease installation of the seal, lubricate the bellows and stationary seat O-rings with water or a very **small** amount of “P-80[®] Emulsion, and apply a drop of light “P-80[®] Emulsion on the finished faces. Assemble the seal as follows, (see Figure 12).

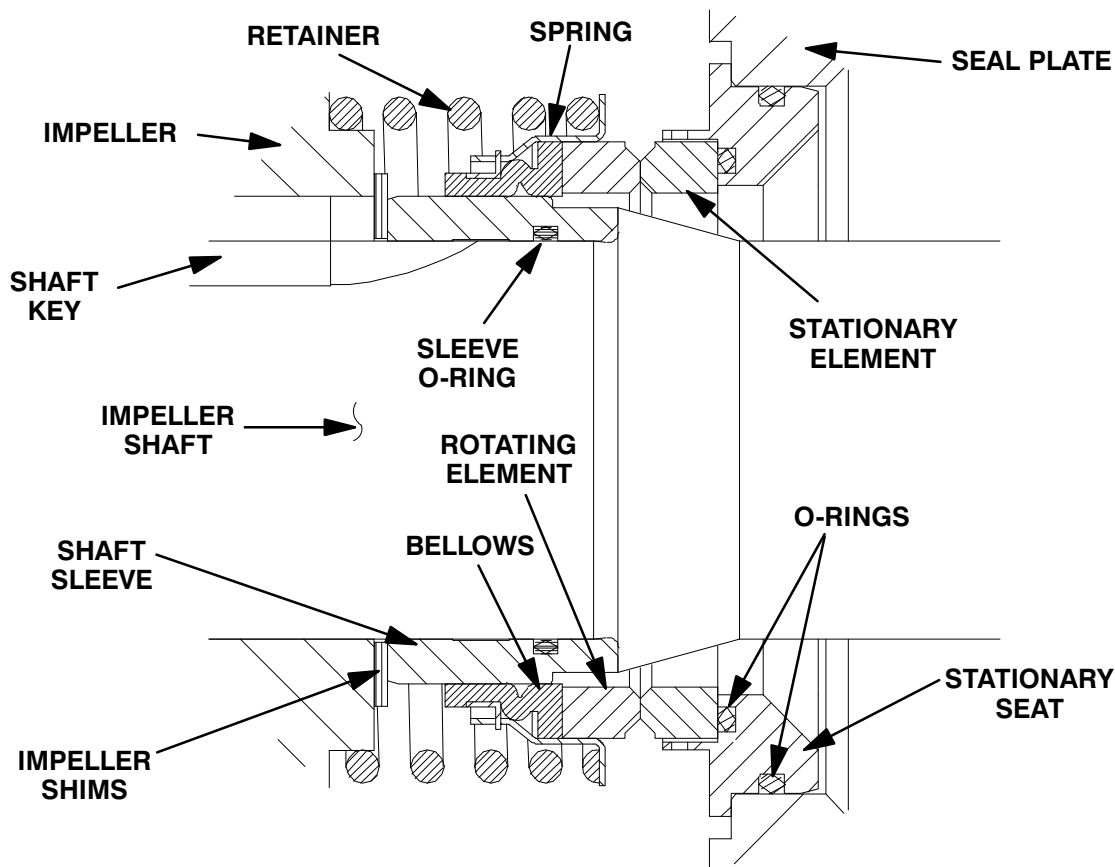

Figure 12. Seal Assembly



The standard seal is not designed for operation at temperatures above 160°F (71°C). Do not use at higher operating temperatures.

Lubricate the outboard stationary seat O-ring with water or light oil. Position the seal plate with the impeller side up and press the stationary subassembly (consisting of the stationary seat, O-rings and stationary element) into the front of the seal plate until it seats squarely against the bore shoulder.

Slide the seal plate and stationary portion of the seal over the shaft until it is seated against the pedestal (20). **Be careful** not to damage the stationary element or roll or cut the lip of the oil seal (23) on the shaft keyway. Temporarily secure the seal plate to the pedestal with three 1/2-inch by 2-inch long capscrews and nuts (not supplied).

Lubricate the seal sleeve O-ring with a **small** amount of light oil and install it in the groove in the I.D. of the sleeve.

Lubricate the seal sleeve with a **small** amount of light oil and slide the rotating subassembly (consisting of rotating element, bellows and retainer), onto the sleeve until the rotating element is **just flush** with the **turned** end of the sleeve.

Slide the sleeve and subassembled seal onto the shaft until the seal faces contact and the sleeve seats against the shaft shoulder.

Install the seal spring. Lubricate the seal as indicated in **LUBRICATION** after the impeller, remaining pump components, bottle oiler and piping are installed.

Impeller Installation

(Figure 6)

Inspect the impeller, and replace it if cracked or badly worn. If the impeller wear ring was removed, chill the impeller by refrigeration and use an induc-

tion heater or oven to heat the new wear ring. Slide the wear ring onto the impeller until fully seated against the shoulder and allow it to cool.

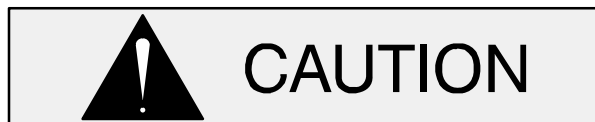

The wear ring **must** seat squarely on the impeller; otherwise binding and/or excessive wear will occur. Use caution when handling hot parts to prevent burns.

Install the same thickness of impeller adjusting shims (42) as previously removed. Install the shaft key (33, Figure 7) and press the impeller assembly onto the shaft until fully seated.

A clearance of approximately .015 inch (0,38 mm) between the impeller and the seal plate is recommended for maximum pump efficiency. Measure this clearance, and add or remove impeller adjusting shims as required.

After the impeller clearance has been set, align the pin (9) in the impeller washer (8) with the hole in the impeller and install the washer. Apply “Never-Seez” or equivalent compound on the threads of the impeller capscrew (7). Immobilize the shaft and secure the the impeller by torquing the capscrew to 225 ft. lbs. (2700 in. lbs. or 31 m. kg.).

Pump Casing Installation

(Figure 6)

Install the casing gasket (6) over the pump casing studs (4 and 5). Remove the hardware temporarily securing the seal plate to the pedestal. Use a suitable hoist and sling to position the volute over the impeller and slide the studs through the seal plate and pedestal mounting holes.

(Figure 7)

Install the bottle oiler bracket (12) over the volute studs. Secure the bracket and volute casing with the hardware (13, 14, and 15). Reconnect the hose (48) to the connector (11) in the seal plate and secure it with the hose clamp (10).

Suction Head And Wear Ring Installation

(Figure 6)

If the wear ring (51) was removed, chill the wear ring by refrigeration and heat the suction head. Slide the wear ring into the suction head until fully seated and allow it to cool.



The wear ring **must** seat squarely in the suction head; otherwise binding and/or excessive wear will occur. Use caution when handling hot parts to prevent burns.

The wear ring is secured to the suction head with the spiral pins (50). Drill three evenly spaced 3/16-inch diameter x 3/4-inch deep holes through the wear ring and into the suction head. Tap the spiral pins into the holes until fully seated.

Install the suction head gasket (52). Position the suction head over the studs (53) and secure it with the hardware (14 and 15).

Turn the impeller shaft by hand and check for any scraping or binding and correct it before putting the pump into service.

Discharge Check Valve Assembly and Installation

(Figure 5)

The flapper and gasket are the only serviceable parts of the check valve. If the flapper requires replacement, remove the hardware securing the cover and gasket. Separate the valve cap and replace the flapper.

Install the valve cap gasket and secure the cap with the previously removed hardware.

Support the discharge check valve assembly (5) using a sling and a suitable lifting device. Secure the discharge check valve assembly and gasket (6) to the pump assembly (1) using the hardware (2, 3 and 4).

See Figure 1 and secure the check valve to the check valve support bracket (17) with the previously removed hardware.

Priming Chamber Assembly And Installation

(Figure 9)

Clean and inspect the components of the priming valve (1). Inspect the linkage and ensure the orifice button squarely engages the valve seat. Replace the orifice button if required (see **Priming Chamber Removal and Disassembly** for orifice button removal).

If the orifice button was removed, screw the new orifice button into the linkage bar until fully seated. Align the hole in the linkage bar with the holes in the bracket and reinstall the pivot pin. Secure the pivot pin with the previously removed “e-clip”.

Adjust the orifice button seating as necessary by screwing the orifice button into or out of the linkage bar. Proper adjustment is achieved when the orifice button fully seats against the orifice before the linkage bar on the float bottoms against the threads on the orifice button. When adjustment is complete, install and tighten the lock washer and hex nut securing the orifice button.

Install the strainer (6) and priming chamber gasket (4).

Lower the float into the priming chamber (5) and secure the priming chamber with the previously removed hardware (1 and 2).

(Figure 8)

Install the baffle (7) and gasket (8) and use a sling and suitable lifting device to position the priming chamber assembly against the pump suction flange. Secure the priming chamber assembly with the hardware (4 and 5).

Reconnect both the suction piping and the air discharge tubing to the priming chamber assembly.

LUBRICATION

Seal Assembly

(Figure 7)

Fill the bottle oiler (54) and seal cavity with approximately 85 ounces (2,5 liters) of SAE No. 30 non-de-

tergent oil. Check the oil level regularly and refill as required.

Bearings

(Figure 7)

The pedestal was fully lubricated when shipped from the factory. Check the oil level regularly through the sight gauges (18) and maintain it at the midpoint of the gauges. When lubrication is required, remove the vented plug (19) and add SAE No. 30 non-detergent oil through the opening. Clean and reinstall the vented plug. **Do not** over-lubricate. Over-lubrication can cause the bearings to over-heat, resulting in premature bearing failure.

NOTE

The white reflector in the sight gauge must be positioned horizontally to provide proper drainage.

Under normal conditions, drain the bearing housing once each year and refill with approximately 14 ounces (0,4 liter) of clean oil. Change the oil more frequently if the pump is operated continuously or installed in an environment with rapid temperature change.



Monitor the condition of the bearing lubricant regularly for evidence of rust or moisture condensation. This is especially important in areas where variable hot and cold temperatures are common.

For cold weather operation, consult the factory or a lubricant supplier for the recommended grade of oil.

Engine

Consult the literature supplied with the engine, or contact your local engine representative.

**For Warranty Information, Please Visit
www.grpumps.com/warranty
or call:
U.S.: 419-755-1280
Canada: 519-631-2870
International: +1-419-755-1352**

GORMAN-RUPP PUMPS