

Basic Pump



Self Priming Centrifugal Pump

Models RD3A31-BAR and RD3A32-BAR

Size 4" x 3"

PUMP SPECIFICATIONS

Size: 4" x 3" (102 mm x 76 mm) Flanged.

Casing: (RD3A31-BAR) Ductile Iron 65-45-12.
(RD3A32-BAR) Cast Steel 70-36.

Maximum Operating Pressure 144 psi (992 kPa).*

Enclosed Type, Five Vane Impeller: Aluminum Alloy SG70A-T6.
Handles 3/8" (9,5 mm) Diameter Spherical Solids.

Impeller Shaft: Steel 1045.

Rotor: Copper Alloy C93400.

Bearing Housing: Ductile Iron 65-45-12.

Bearing Housing Lubrication: Grease.

Body Cover: (RD3A31-BAR) Ductile Iron 65-45-12.
(RD3A32-BAR) Cast Steel 70-36.

Center/Spacer Plate: (RD3A31-BAR) Ductile Iron 65-45-12.
(RD3A32-BAR) Cast Steel 70-36.

Radial Bearing: Permanently Sealed Single Row Ball Type.

Thrust Bearing: Permanently Sealed Single Row Ball Type.

Gaskets: Buna-N and PTFE.

Priming: Rotary Vane Type Priming Pump.

Air Release Valve: (RD3A31-BAR) Ductile Iron/Stainless Steel.
(RD3A32-BAR) Steel/Stainless Steel.

Optional Equipment: Cast Steel 70-36 Threaded Suction and Discharge Companion Flange Kit, Copper Alloy C93400 Impeller, Group Grind with Cast Iron Rotor (RD3A31-BAR Only); Stainless Steel 416 Impeller Shaft, Buna-N Seal, PTFE Seal with Fluorocarbon O-Ring, PTFE Seal with Buna-N O-Ring, Oil Filled Bearing Housing Assembly. Extreme Duty Air Release Valve (GRP33-08).

*Consult Factory for Applications Exceeding Maximum Pressure and/or Temperature Indicated.

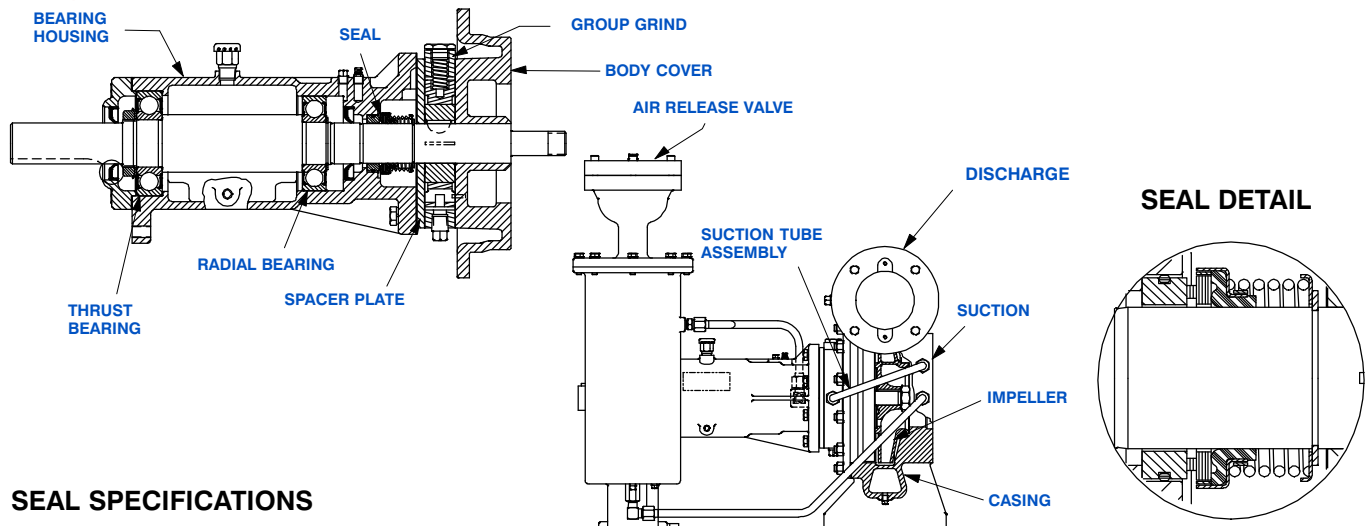
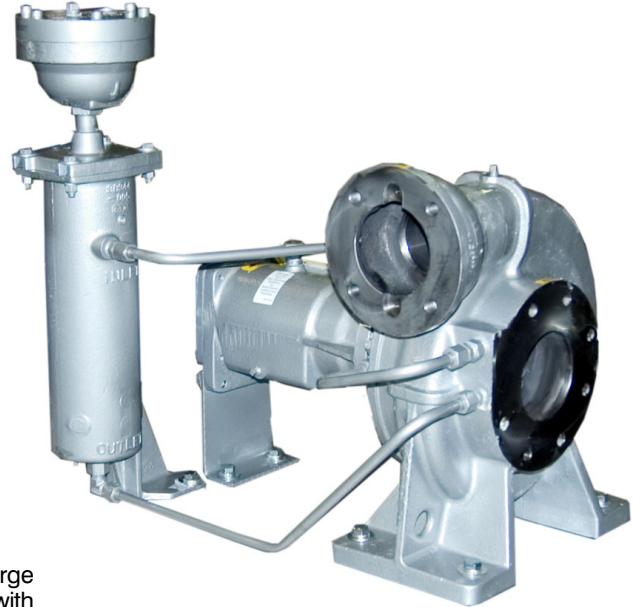

SEAL SPECIFICATIONS

Seal: Mechanical; Self-Lubricated. Fluorocarbon Elastomers (DuPont Viton[®] or Equivalent). Carbon Rotating Face; Ni-Resist Stationary Face; Maximum Temperature of Liquid Pumped is 160°F (71°C).*



GORMAN-RUPP PUMPS

www.grpumps.com

Specifications Subject to Change Without Notice

Printed in U.S.A.

Specification Data

OVERALL DIMENSIONS
and
APPROXIMATE WEIGHTS

NET WEIGHT:

RD3A31-BAR

292 LBS. (132,4 KG.)

SHIPPING WEIGHT:

312 LBS. (141,5 KG.)

EXPORT CRATE SIZE:

17.9 CU. FT. (0,51 CU. M.)

RD3A32-BAR

295 LBS. (133,8 KG.)

308 LBS. (139,7 KG.)

SECTION 35, PAGE 410

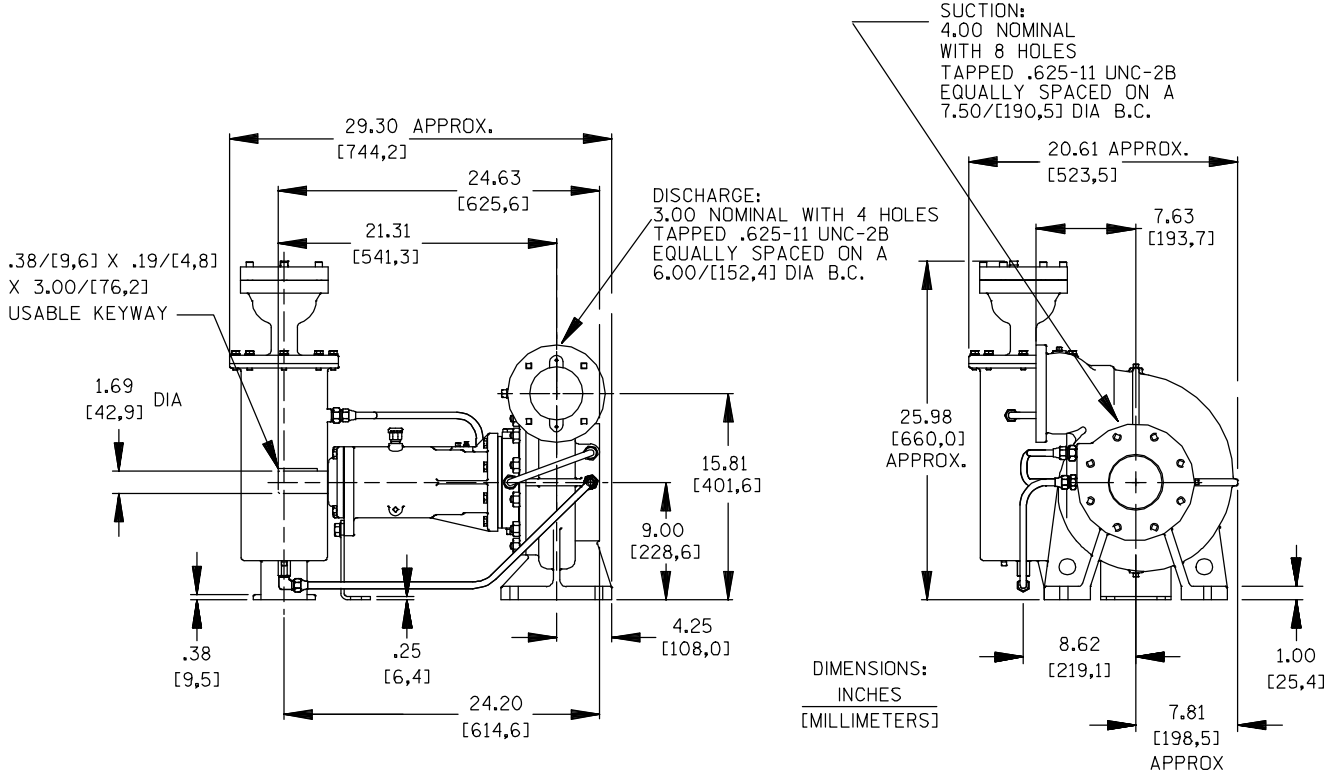

**PERFORMANCE
BASED ON
PETROLEUM
TRIMMED
IMPELLER**

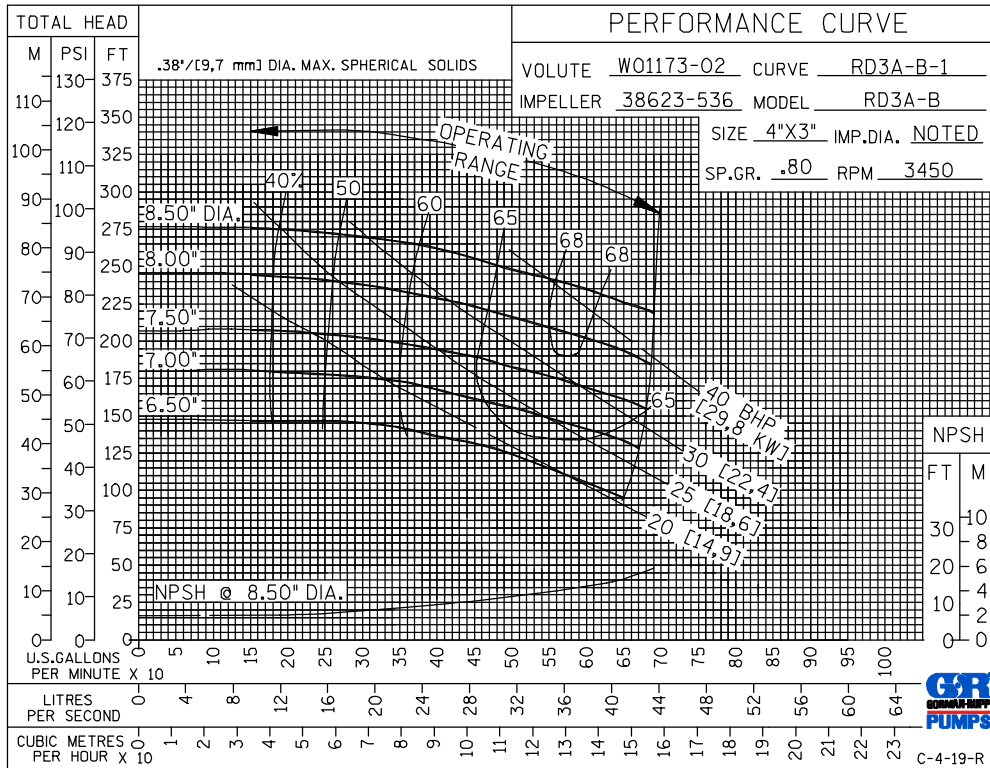

GORMAN-RUPP PUMPS

www.grpumps.com

Specifications Subject to Change Without Notice

Printed in U.S.A.

