



Self Priming Centrifugal Pump

Models RD4A31-B and RD4A32-B

Size 6" x 4"

PUMP SPECIFICATIONS

Size: 6" x 4" (152mm x 102 mm) Flanged.

Casing: (RD4A31-B) Ductile Iron 65-45-12.
(RD4A32-B) Cast Steel 70-36.

Maximum Operating Pressure 203 psi (1386 kPa).*

Enclosed Type, Five Vane Impeller: Aluminum 356-T6.

Handles 1/2" (12,7 mm) Diameter Spherical Solids.

Impeller Shaft: Steel 1045.

Rotor: Copper Alloy C93400.

Bearing Housing: Ductile Iron 65-45-12.

Body Cover: (RD4A31-B) Ductile Iron 65-45-12.
(RD4A32-B) Cast Steel 70-36.

Center/Spacer Plate: (RD4A31-B) Ductile Iron 65-45-12.
(RD4A32-B) Cast Steel 70-36.

Radial Bearing: Open Double Row Ball Type.

Thrust Bearing: Open Single Row Ball Type.

Bearing Lubrication: SAE 30 Non-Detergent Oil.

Gaskets: Vegetable Fiber, PTFE and Cork.

Priming: Rotary Vane Type with Built-in Spring-Loaded Priming Assist Valve.

Optional Equipment: Stainless Steel 416 Impeller Shaft, Buna-N Seal, PTFE Seal with Fluorocarbon O-Ring, PTFE Seal with Buna-N O-Ring, Standard 4" Check Valve (Required for Priming).

**Consult Factory for Applications Exceeding Maximum Pressure and/or Temperature Indicated.*

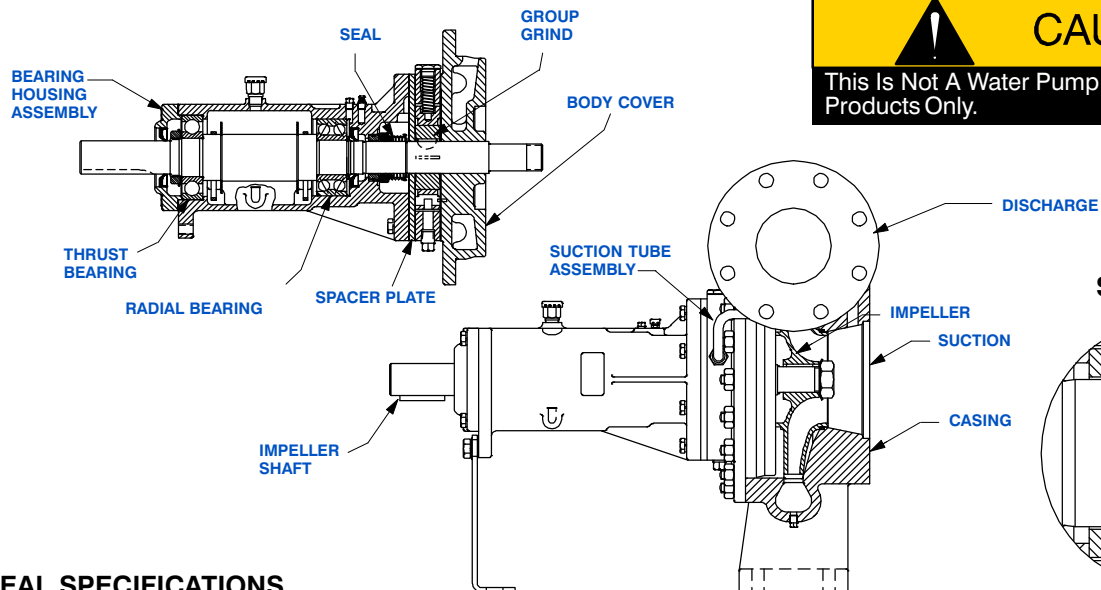
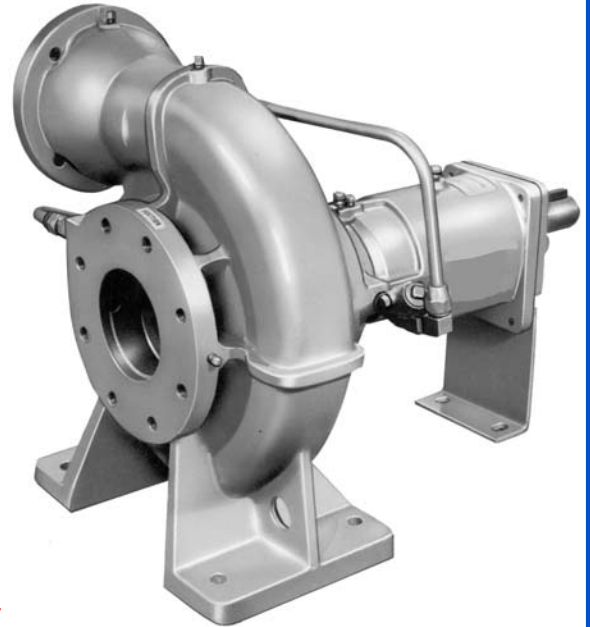

SEAL SPECIFICATIONS

Seal: Mechanical; Self-Lubricated. Fluorocarbon Elastomers (DuPont Viton[®] or Equivalent). Carbon Rotating Face; Ni-Resist Stationary Face; Maximum Temperature of Liquid Pumped is 160°F (71°C).*



GORMAN-RUPP PUMPS

www.grpumps.com

Specifications Subject to Change Without Notice

Printed in U.S.A.

Specification Data

SECTION 35, PAGE 500

OVERALL DIMENSIONS
and
APPROXIMATE WEIGHTS

RD4A31-B

RD4A32-B

PUMP NET WEIGHT: 326 LBS. (147,9 KG.) 348 LBS. (157,9 KG.)
SHIPPING NET WEIGHT: 346 LBS. (156,9 KG.) 363 LBS. (164,7 KG.)
EXPORT CRATE SIZE: 18 CU. FT. (0,51 CU. M.)

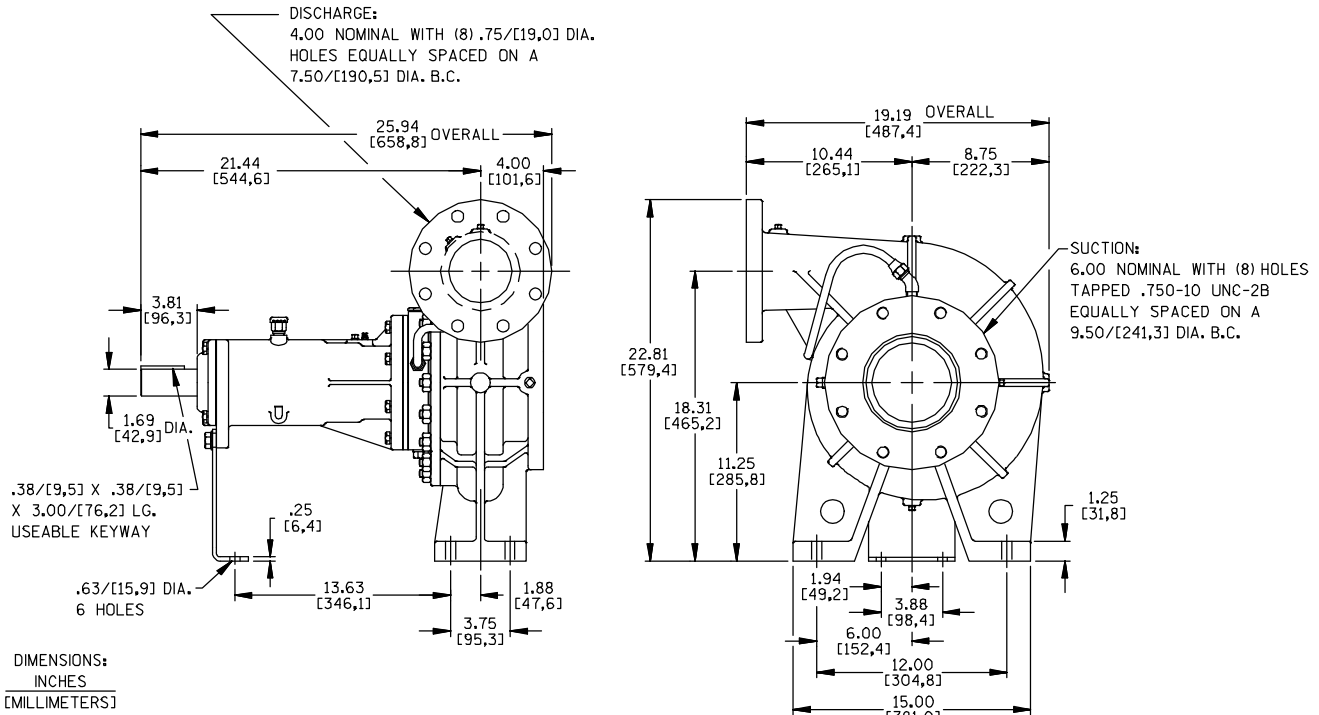

Air Release Valve Required When Static Discharge Pressure Exceeds 8 psi (55 kPa).

**PERFORMANCE
BASED ON
PETROLEUM
TRIMMED
IMPELLER**

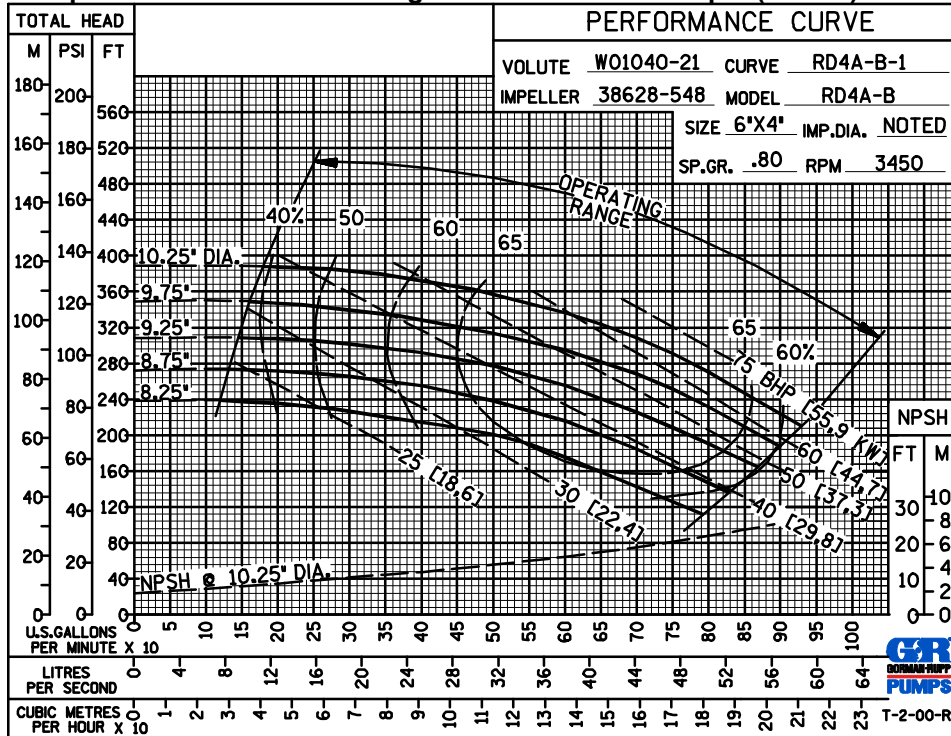

GORMAN-RUPP PUMPS

www.grpumps.com

Specifications Subject to Change Without Notice

Printed in U.S.A.

50 HERTZ
PERFORMANCE
BASED ON
PETROLEUM
TRIMMED
IMPELLER

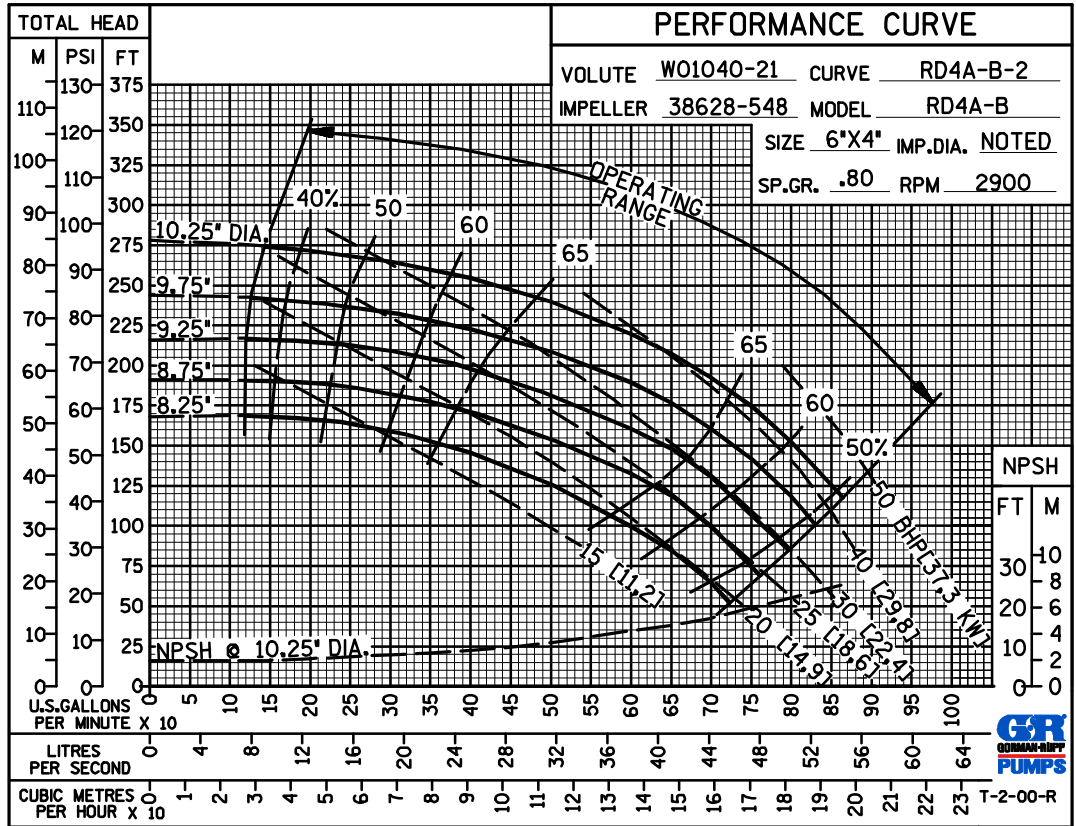

GORMAN-RUPP PUMPS

www.grpumps.com

Specifications Subject to Change Without Notice

Printed in U.S.A.