



Priming Assisted Centrifugal Pump w/Autostart

Model PA12A60-B-4045H FT4 Size 12" x 12"



Total Head		Capacity of Pump in U.S. Gallons per Minute (GPM) at Continuous Performance				
P.S.I.	Feet					
45.1	104	1100	1100	1100	1100	1100
43.4	100	2000	2300	2300	2300	2300
39.0	90	2700	3620	3750	3750	3750
34.7	80	3000	4110	4650	4700	4700
30.4	70	3090	4250	5050	5450	5430
26.0	60	3140	4300	5100	5740	5920
22.7	50	3200	4350	5150	5850	6030
17.3	40	3290	4400	5200	5900	6100
13.0	30	3340	4440	5250	5910	6190
Suction Lift		25'	20'	15'	10'	5'

PUMP SPECIFICATIONS

Size: 12" x 12" (305 mm x 305 mm) -Flanged.

Casing: Gray Iron 30.

Maximum Operating Pressure 71 psi (490 kPa).*

Enclosed Type, Three Vane Impeller: Ductile Iron 60-40-18.

Handles 3" (76.2 mm) Diameter Spherical Solids.

Impeller Shaft: Stainless Steel 17-4 PH.

Shaft Sleeve: Stainless Steel 17-4 PH.

Replaceable Wear Plate: Steel 1015.

Intermediate Bracket: Gray Iron 30.

Seal Plate: Gray Iron 30.

Seal: Mechanical, Oil-Lubricated, Double Floating Self-Aligning. Silicon Carbide Rotating and Stationary Faces. Stainless Steel 316 Stationary Seat. Fluorocarbon Elastomers (DuPont Viton® or Equivalent). Stainless Steel 18-8 Cage and Spring. Maximum Temperature of Liquid Pumped 160°F (71°C).*

Priming Chamber: Gray Iron 30 Housing w/Stainless Steel Float and Linage.

Discharge Check Valve: Ductile Iron w/Buna-N Flapper.

Radial Bearing: Open Single Row Ball.

Thrust Bearing: Open Double Row Ball.

Bearing and Seal Cavity Lubrication: SAE 30 Non-Detergent Oil.

Flanges: Gray Iron 30.

Gaskets: Resistant Synthetic Rubber, Cork, PTFE, Vegetable Fiber, and Compressed Synthetic Fibers.

Hardware: Standard Plated Steel.

Bearing and Seal Cavity Oil Level Sight Gauges.

*Consult Factory for Applications Exceeding Maximum Pressure and/or Temperature Indicated.

Standard Equipment: Hoisting Bail. Skid Base. Gear-Driven Air Compressor. [Single Ball Type Float Switch..](#) [Full Feature Control Panel](#)

Optional Equipment: Battery. Strainer. Heated Priming Chamber Kit. Suction and Discharge NPT Threaded Flange Kits. Submersible Transducer Liquid Level Sensor.**

**50 Ft. (15 m) Standard Length; Dual Switches and Alternate Cable Lengths Available From the Factory.



ENGINE SPECIFICATIONS

Model: John Deere 4045HFC06.

EPA Tier: Final Tier 4.

Type: Four Cylinder, Turbocharged, Diesel Engine with Air Compressor.

Displacement: 276 Cu. In. (4.5 liters).

Lubrication: Forced Circulation.

Air Cleaner: Dry Type.

Fuel Tank: 206 U.S. Gals. (780 liters).

Full Load Operating Time: 25.5 Hrs.

Starter: 12V Electric.

Standard Features: Muffler w/Guard and Weather Cap, DOC/SCR Exhaust After-Treatment System.

Optional: Electronic Fuel Level Sensor.

Engine Control Features: Padlockable Box with Throttle Control, Tachometer, Coolant Temperature, Oil Pressure, Voltage and Overstart Indicators/Shut-downs. Manual/Stop/Auto Keyswitch. Audible Startup Warning Delay. Fuel Level Display/Alarm/Shut-down (For Use With Optional Fuel Level Sensor).

JOHN DEERE PUBLISHED PERFORMANCE:
Maximum Net Continuous BHP
156 (116 kW) @ 2200 RPM



GORMAN-RUPP PUMPS

www.grpumps.com

Specifications Subject to Change Without Notice

Printed in U.S.A.

Specification Data

SECTION 42, PAGE 1806

APPROXIMATE
DIMENSIONS and WEIGHTS

NET WEIGHT:
SHIPPING WEIGHT:
EXPORT CRATE SIZE:

SKID BASE

6220 LBS. (2821 KG.)
6520 LBS. (2957 KG.)
732 CU. FT. (20,7 CU. M.)

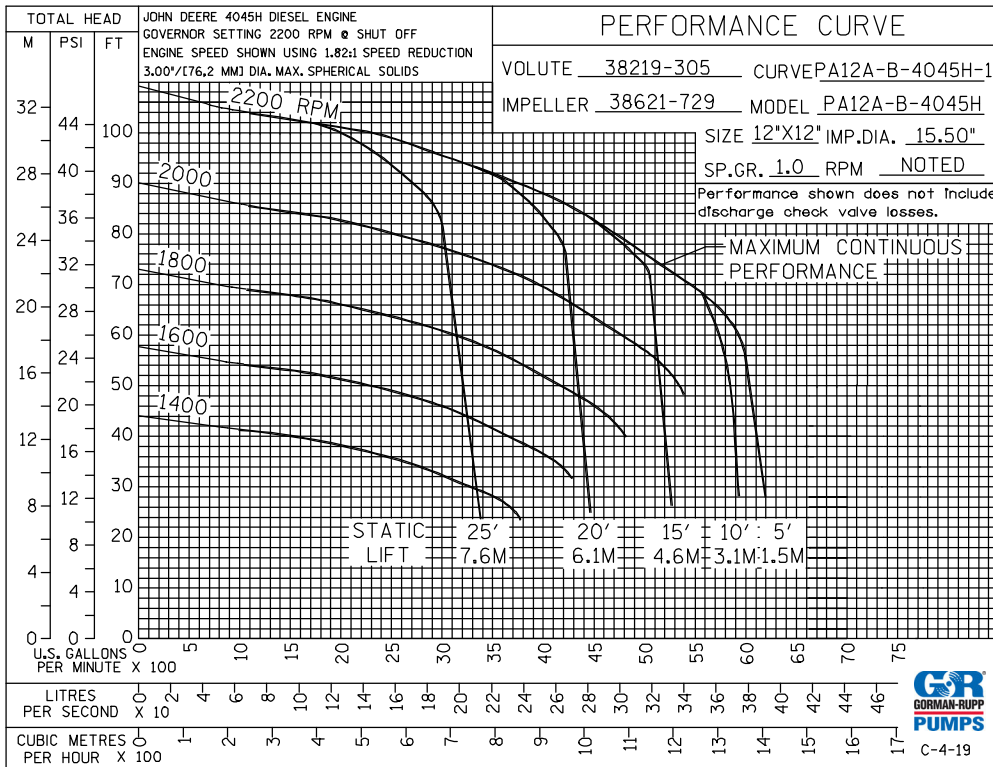
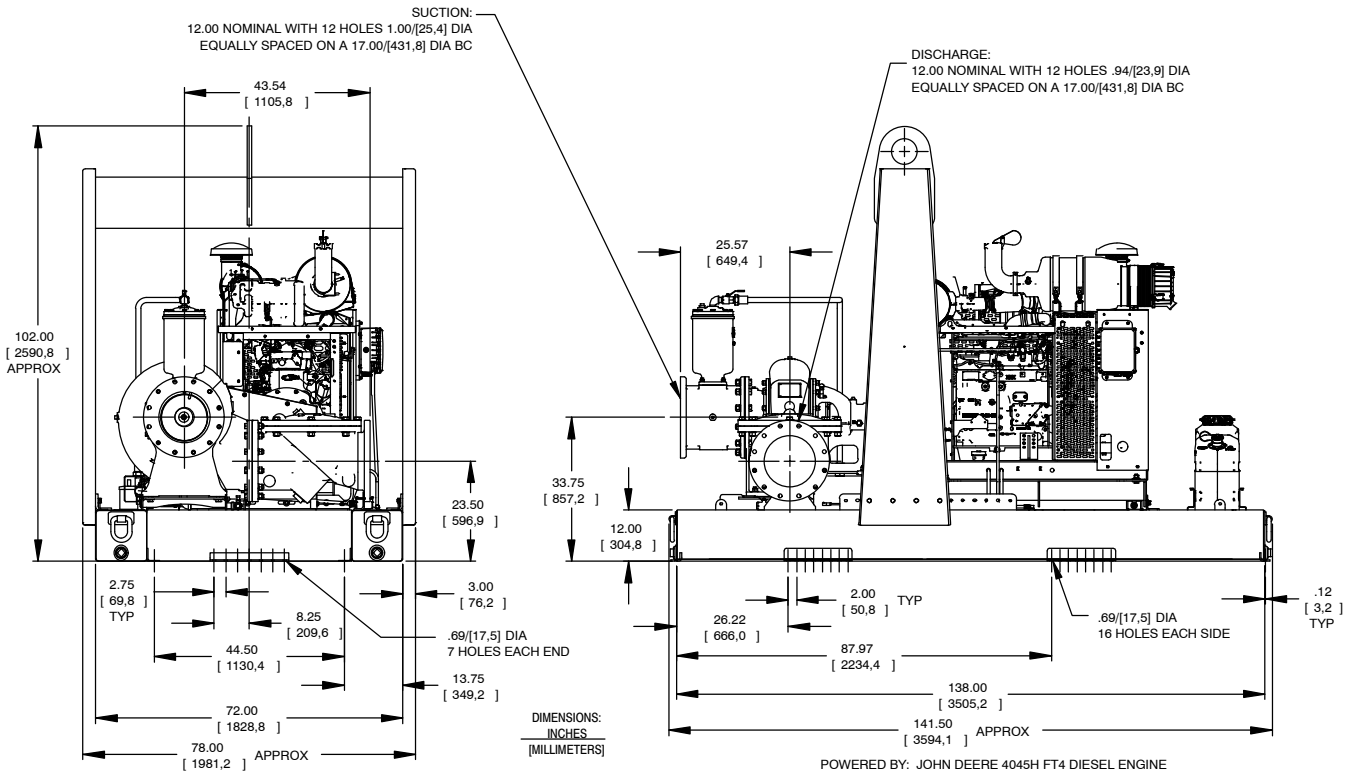

GORMAN-RUPP PUMPS

www.grpumps.com

Specifications Subject to Change Without Notice

Printed in U.S.A.