



Self Priming Centrifugal Pump

Models 12B2-B and 12B20-B

Size 2" x 2"

PUMP SPECIFICATIONS

Size: 2" x 2" (51 mm x 51 mm) NPT - Female.

Casing: Gray Iron 30.

Maximum Operating Pressure 59 psi (407 kPa).*

Semi-Open Type, Two Vane Impeller: Ductile Iron 65-45-12.

Handles 1 1/4" (31,8 mm) Diameter Spherical Solids.

Impeller Shaft: Carbon Steel 1215.

Replaceable Wear Plate: Carbon Steel 1026.

Removable Cover Plate: Gray Iron No. 30. Weight 10 lbs. (5 kg).

Pedestal: Gray Iron 30.

Seal Plate: Gray Iron 30.

Flap Valve: Buna-N and Gray Iron 30.

Seal Liner: (12B2-B) Copper Alloy C26000.

Shaft Sleeve: (12B20-B) Alloy Steel 4130.

Radial and Thrust Bearings: Open Single Row Ball.

Bearing Lubrication: SAE 30 Non-Detergent Oil.

Flange: Gray Iron 30.

Gaskets: Vegetable Fiber and Rubber.

O-Ring: Buna-N.

Hardware: Standard Plated Steel.

Optional Equipment: Strainer. Flanged Suction and Discharge.

120/240 Volt Casing Heater. High Temp Shut Down Kit.

**Consult Factory for Applications Exceeding Maximum Pressure and/or Temperature Indicated.*

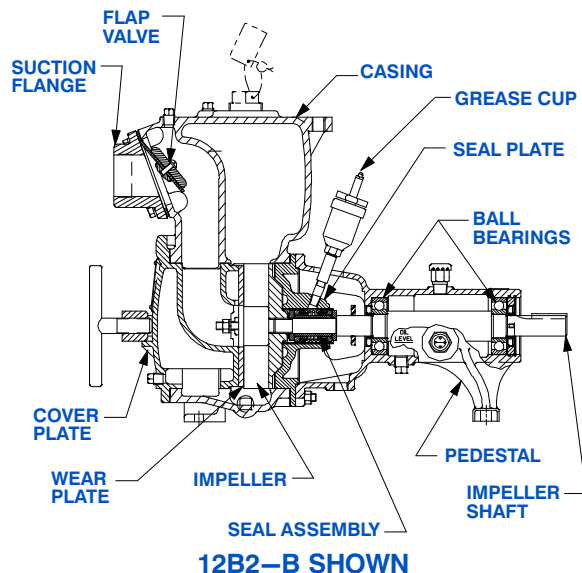

12B2-B SEAL DETAIL

Double, Grease-Lubricated with Spring-Loaded Grease Cup. Steel Rotating Faces. Sintered Bronze Stationary Seal Seats. Neoprene Packing Rings. Maximum Temperature of Liquid Pumped, 110°F (43°C). Maximum Suction Pressure 10 PSI (69 kPa).*

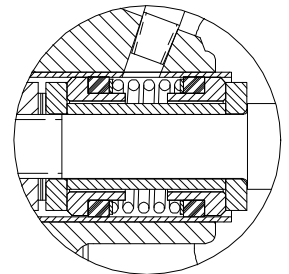

12B20-B SEAL DETAIL

Mechanical, Oil-Lubricated, Double Floating, Self-Aligning. Tungsten Titanium Carbide Rotating and Stationary Faces. Stainless Steel 316 Stationary Seat. Fluorocarbon Elastomers (DuPont Viton® or Equivalent). Stainless Steel 303/304 Cage and Spring. Maximum Temperature of Liquid Pumped, 160°F (71°C).*

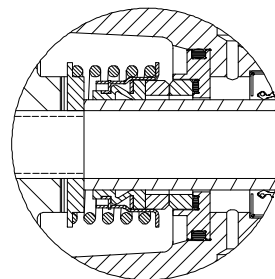

GORMAN-RUPP PUMPS

www.grpumps.com

Specifications Subject to Change Without Notice

Specification Data

SECTION 55, PAGE 200

APPROXIMATE
DIMENSIONS and WEIGHTS

NET WEIGHT: 111 LBS. (50 KG.)

SHIPPING WEIGHT: 121 LBS. (55 KG.)

EXPORT CRATE SIZE: 6.2 CU. FT. (0,07 CU. M.)

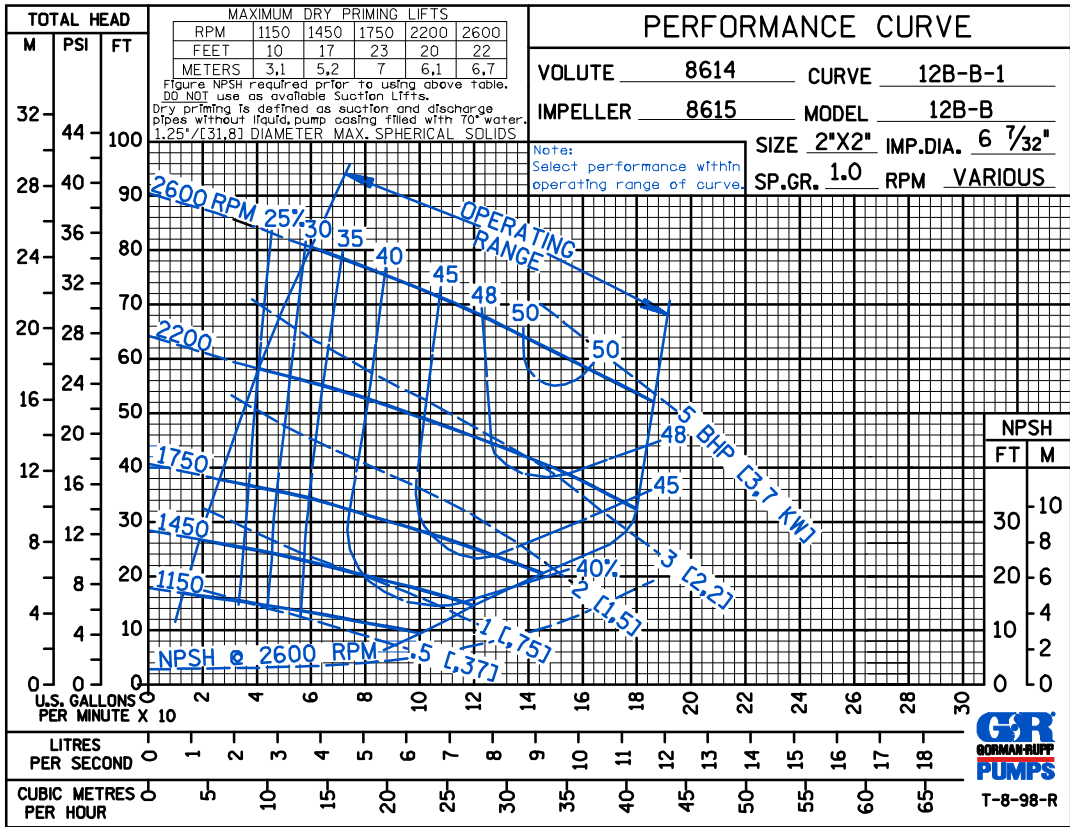
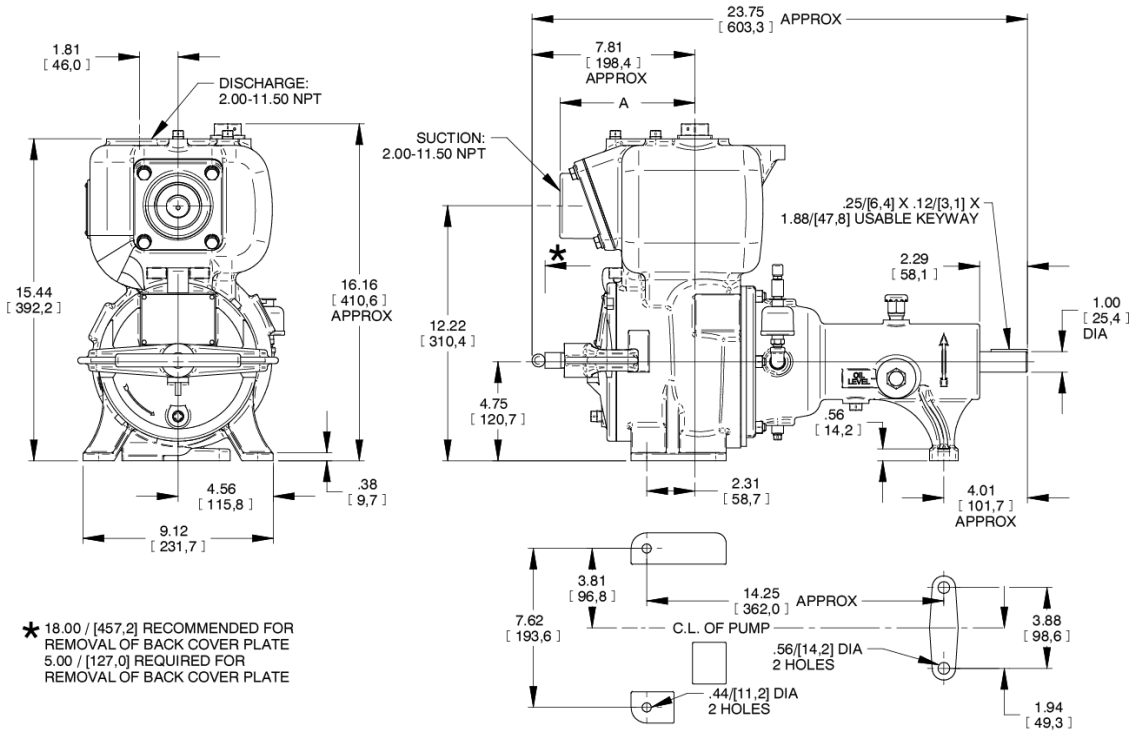

GORMAN-RUPP PUMPS

www.grpumps.com

Specifications Subject to Change Without Notice