



Basic Pedestal

Standard Centrifugal Pump

Model VG2C3-B

Size 2 1/2" x 2"

PUMP SPECIFICATIONS

Size: 2 1/2" x 2" (64 mm x 51 mm) Flanged.

Casing: Gray Iron 40.

Maximum Operating Pressure 173 psi (1193 kPa).*

Enclosed Type, Six Vane Impeller: Gray Iron 40.

Handles 7/16" (11,1 mm) Diameter Spherical Solids.

Impeller Shaft: Steel 1045.

Shaft Sleeve: Stainless Steel 420.

Seal Plate: Gray Iron 40.

Bearing Housing: Gray Iron 40.

Radial Bearing: Open Single Row Ball.

Thrust Bearing: Open Double Row Ball.

Bearing Lubrication: SAE 30 Non-Detergent Oil.

Gaskets: Nitrile Rubber.

O-Ring: Fluorocarbon (DuPont Viton® or Equivalent).

Hardware: Standard Plated Steel.

Oil Level Sight Gauge.

Optional Equipment: NPT Suction and Discharge Flanges.

Strainer. Stainless Steel Impeller. Mechanical Seal with Fluorocarbon Elastomers (DuPont Viton® or Equivalent).

**Consult Factory for Applications Exceeding Maximum Pressure and/or Temperature Indicated.*

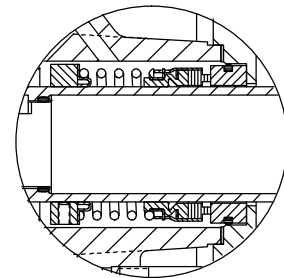
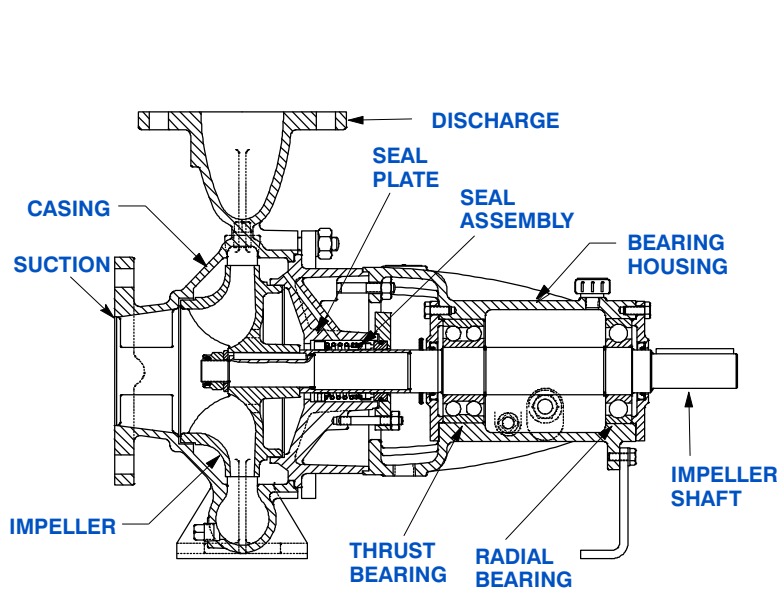

SEAL DETAIL

Type 1, Mechanical, Self-Lubricated. Carbon Rotating Face. Ceramic Stationary Seat. Buna-N Elastomers. Stainless Steel and/or Brass Cage and Spring. Maximum Temperature of Liquid Pumped, 160°F (71°C).*



GORMAN-RUPP PUMPS

www.grpumps.com

Specifications Subject to Change Without Notice

Printed in U.S.A.

Specification Data

SECTION 70, PAGE 255

APPROXIMATE DIMENSIONS and WEIGHTS

NET WEIGHT: 82 LBS. (37,2 KG.)
SHIPPING WEIGHT: 94 LBS. (42,6 KG.)
EXPORT CRATE SIZE: 3.8 CU. FT. (0,11 CU. M.)

DISCHARGE:
 2.00/[50,8] I.D., 6.00/[152,4] O.D., .63/[16,0] THK FLANGE
 4 HOLES .75/[19,1] DIA. EQUALLY SPACED
 ON A 4.75/[120,6] DIA. B.C. OR 2.00" NPT
 COMPANION FLANGE

SUCTION:
 2.50/[63,5] I.D., 7.00/[177,8] O.D.,
 .69/[17,5] THK. FLANGE
 4 HOLES .75/[19,1] DIA. EQUALLY SPACED ON A
 5.50/[139,7] DIA. B.C. OR 2.50" NPT
 COMPANION FLANGE

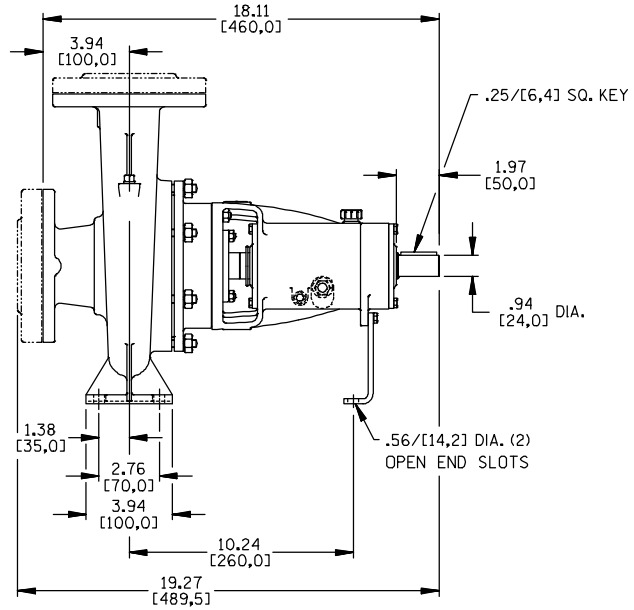
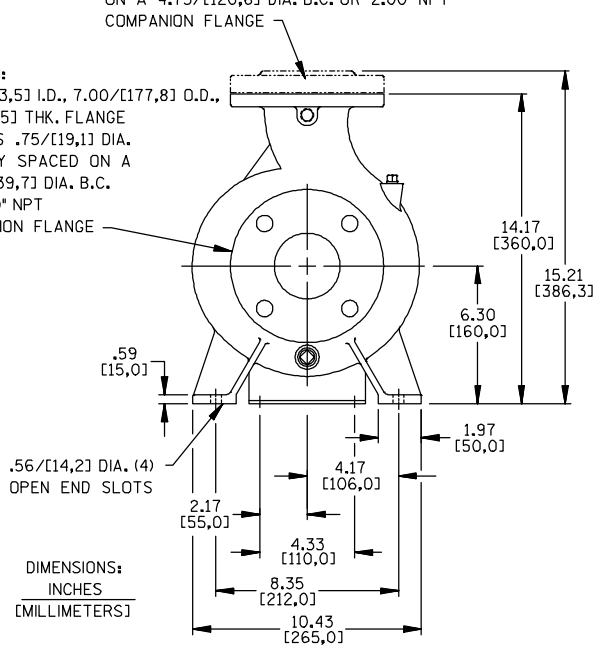

DIMENSIONS:
 INCHES
 [MILLIMETERS]

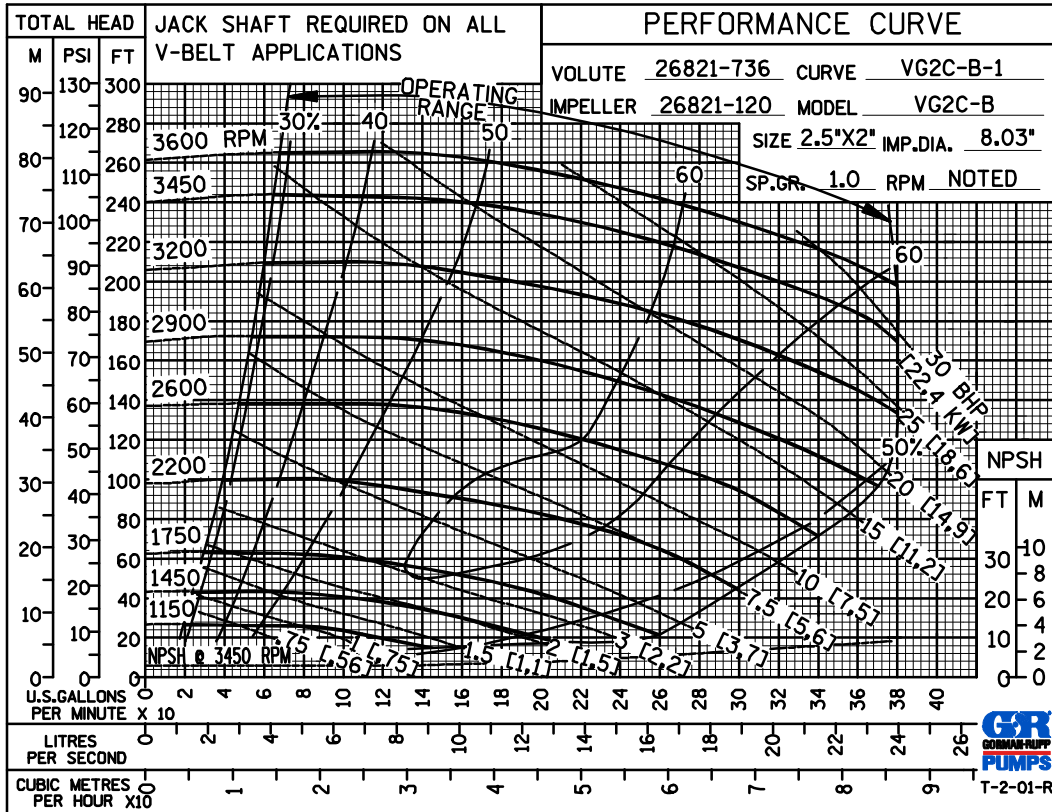

PERFORMANCE
 BASED ON
 WATER



GORMAN-RUPP PUMPS

www.grpumps.com

Specifications Subject to Change Without Notice

Printed in U.S.A.

PERFORMANCE
BASED ON
WATER

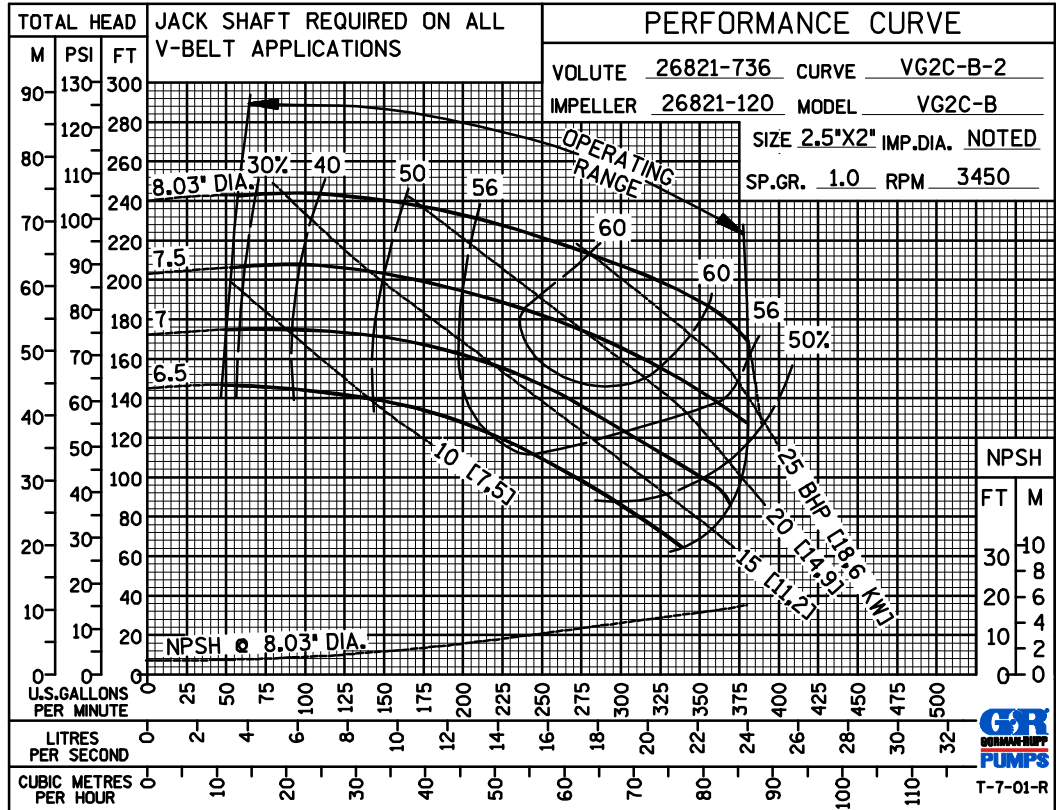

PERFORMANCE
BASED ON
WATER

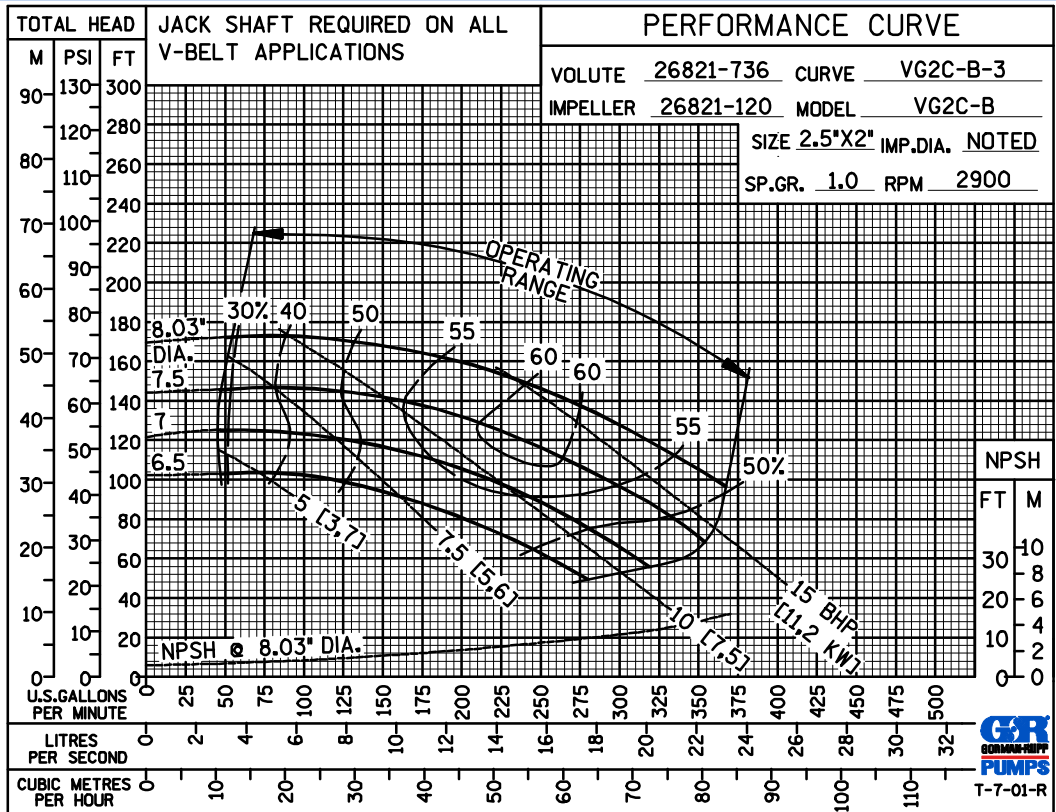

GORMAN-RUPP PUMPS

www.grpumps.com

Specifications Subject to Change Without Notice

Printed in U.S.A.

PERFORMANCE
BASED ON
WATER

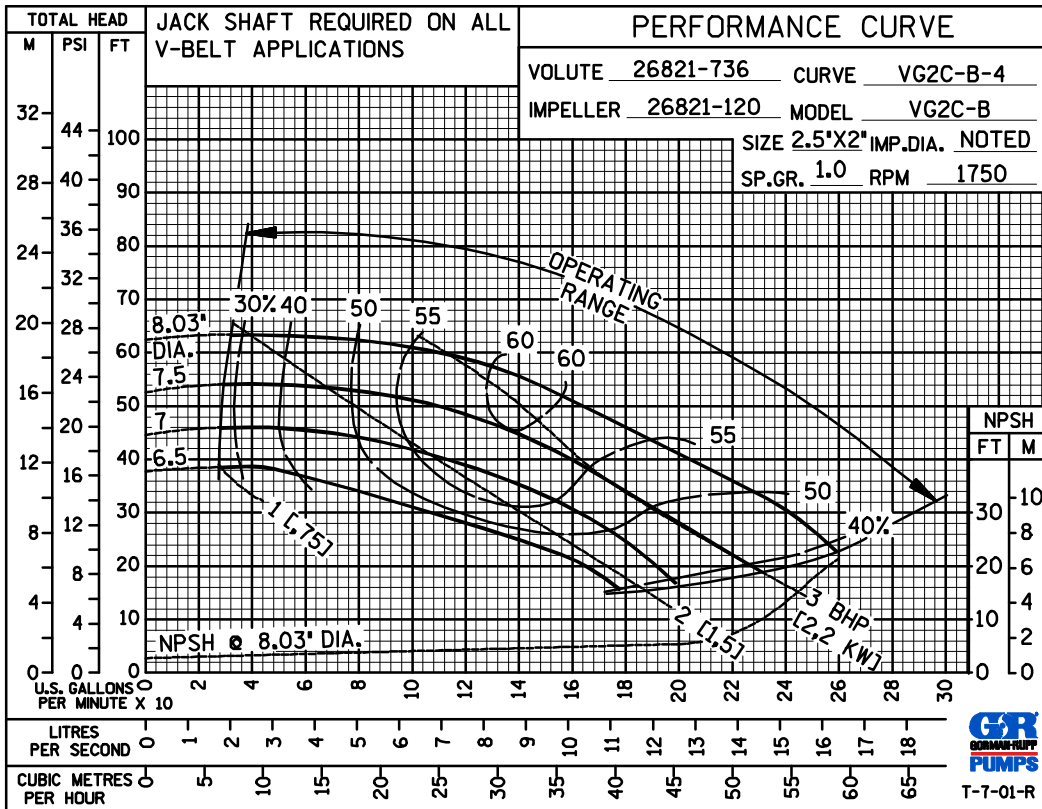

PERFORMANCE
BASED ON
WATER

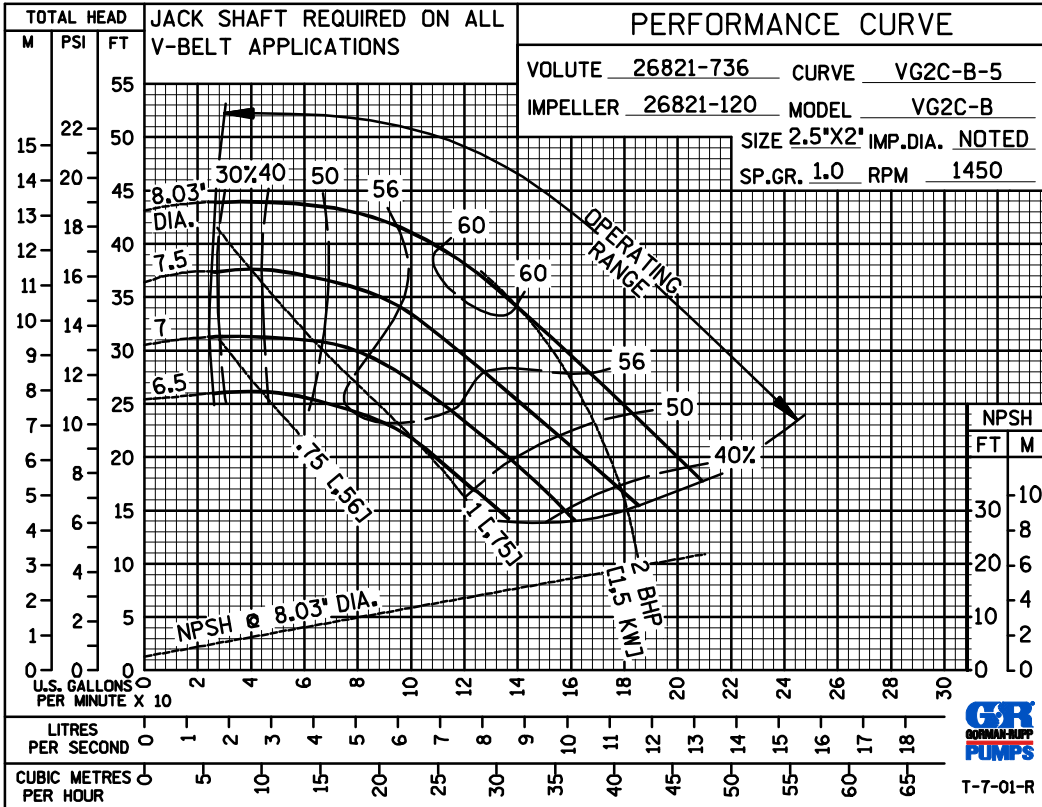

GORMAN-RUPP PUMPS

www.grpumps.com

Specifications Subject to Change Without Notice

Printed in U.S.A.