

Submersible Pump

Model S6A1-E60

Size 6"



PUMP SPECIFICATIONS

- Diffuser:** Ductile Iron 80-60-03;
Maximum Operating Pressure 77 psi (531 kPa).*
- Semi-Open Type, Six Vane Impeller:** Ductile Iron 80-60-03.
- Suction Head:** Ductile Iron 80-60-03.
- Motor Housing:** Aluminum Alloy 356-T6.
- Intermediate Bracket:** Aluminum Alloy 356-T6.
- Strainer Plate:** Aluminum Alloy 356-T6.
- Motor Shaft:** Stainless Steel 17-4 PH.
- Bearings:** Upper, Open Single Row Ball.
Lower, Sealed Double Row Ball.
- Discharge Flange:** Gray Iron 30.
- Gaskets:** Cork ^w/Nitrile Binder (NC710) and Vegetable Fiber.
- O-Ring:** Synthetic Rubber (DuPont Neoprene® or Equivalent).
- Wetted Hardware:** Standard Plated Steel and Stainless Steel.
- Strainer:** Urethane Coated Steel; 59% Open Area, 1.0" (25,4 mm) Square Openings.
- Hoisting Bail.** Urethane Coated Steel.
- Standard Equipment:** NEMA Type 3R Rainproof Control Box.
Provides On-Off, Circuit Breaker and Motor Overload Protection.
(See Section 130, Page 95.)
- Optional Equipment:** Staging Adapter Kit. Turtle Type Pressure Activated Level Switch. Float Activated Level Switch. (See Sec. 130, Page 150.)

MOTOR/CABLE SPECIFICATIONS

- Motor:** Oil Filled Enclosure; 60 H.P.; 1750 R.P.M.;
Three Phase: 460/575 Volt, 60 Hz, 71/58 Full Load Amps, 43 kW (Max.)
- Power Cable:** (460V) 6 Wire; Type GGC; 2 AWG; 3 Power Conductors, plus 2 Ground Conductors and 1 Ground Check. (575V) 6 Wire, Type GGC, 4 AWG; 3 Power Conductors, plus 2 Ground Conductors and 1 Ground Check.
Nominal Length 50 Feet (15 m) Standard. (Specify Alternate Length at Time of Order.)
- Recommended Generator Size:** 100 kW Across the Line Start, 50 kW for Reduced Voltage Starting.

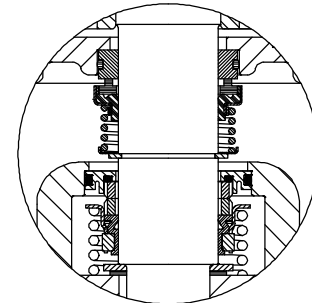
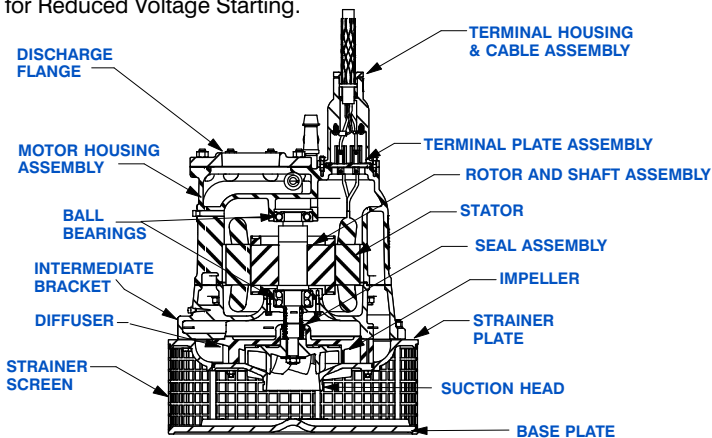

SEAL SPECIFICATIONS

- Tandem, Oil Lubricated.
- Upper Seal:** Type 2, Mechanical. Carbon Rotating Face. Ceramic Stationary Face. Buna-N Elastomers. Stainless Steel 18-8 Cage and Spring.
- Lower Seal:** Type 2, Mechanical. Tungsten Titanium Carbide Rotating and Stationary Faces. Stainless Steel 316 Stationary Seat. Fluorocarbon Elastomers (DuPont Viton® or Equivalent). Stainless Steel 18-8 Cage and Spring.
Maximum Temperature of Liquid Pumped, 122°F (50°C).*
- * Consult Factory for Applications Exceeding Maximum Pressure and/or Temperature Indicated.



GORMAN-RUPP PUMPS

www.grpumps.com

Specifications Subject to Change Without Notice

Printed in U.S.A.

Specification Data

APPROXIMATE
DIMENSIONS and WEIGHTS

NET WEIGHT: 986 LBS. (447 KG.)
SHIPPING WEIGHT: 1070 LBS. (485 KG.)
EXPORT CRATE: 35.2 CU. FT. (1,0 CU. M.)

SECTION 130, PAGE 1365

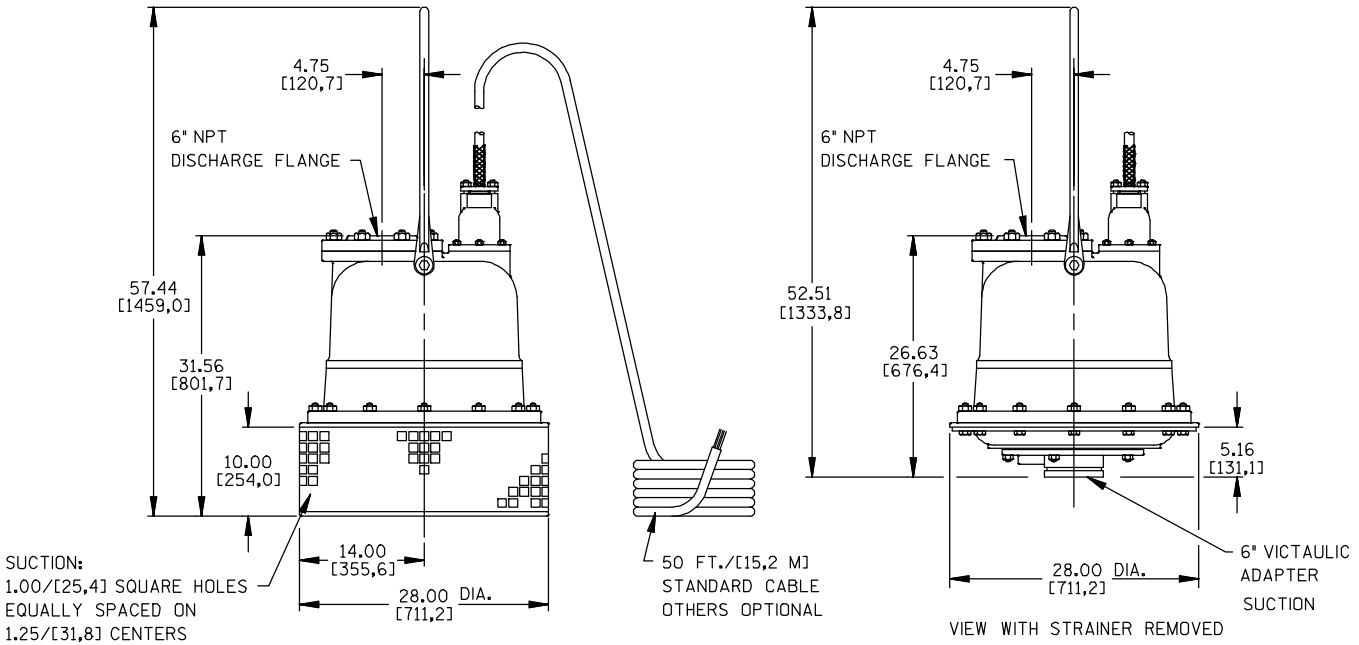

DIMENSIONS:
INCHES
[MILLIMETERS]

Victaulic is a Registered Trademark of Victaulic Company of America.

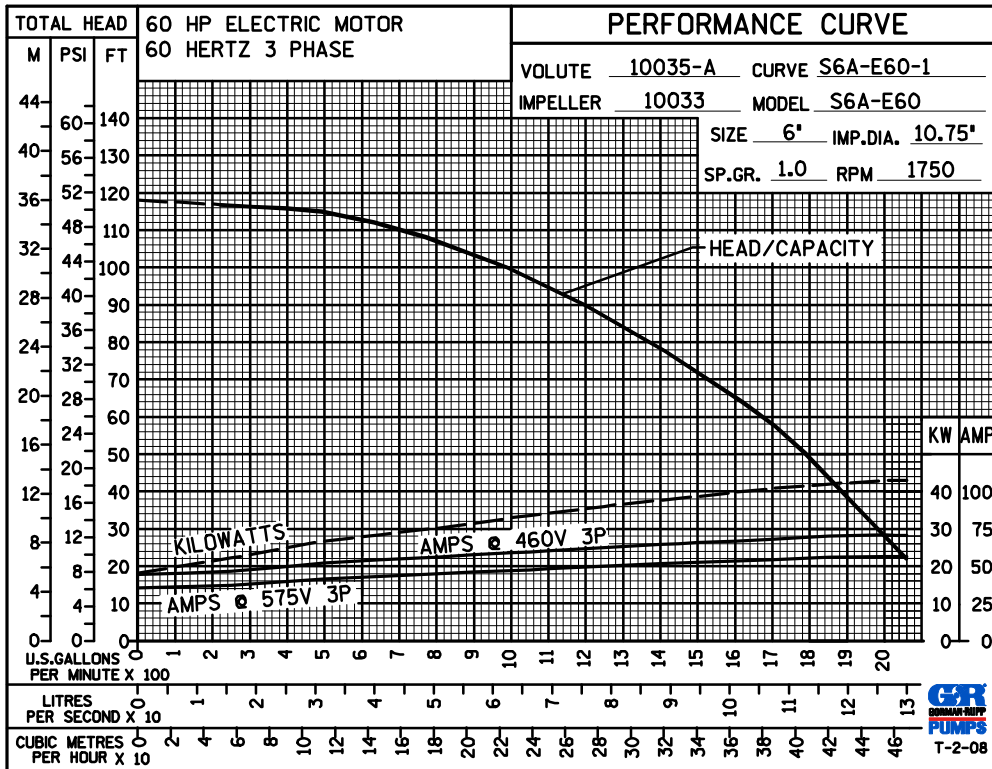

GORMAN-RUPP PUMPS

www.grpumps.com

Specifications Subject to Change Without Notice

Printed in U.S.A.