

SF Series

VARIOUS PATENTS APPLY

**Solids Handling Electric Motor Driven
Submersible Pump
Models
SF8B & SF8B-X
Size 8"**



APPROVED
X-PROOF MOTORS FOR CLASS I,
DIV. 1, GROUPS C&D LOCATIONS
(X-Proof Version Only)

The Gorman-Rupp SF Series® channel pumps provide superior pumping efficiency while maintaining a 3-inch (76,2 mm) spherical solids passage.

Key Features:

- NEMA premium efficiency motors
- Externally adjustable face clearance
- Press-fit motor with finned motor housing provides superior motor cooling, even in a submersed state, resulting in increased motor life
- NEMA Class H motor insulation
- Direct wired power cable leads
- Standard moisture detection in both the seal and motor chambers
- Factory Mutual (FM) Approved for Class I, Division I, Group C and D Haz Loc Applications (X-Proof Model)



Optional Accessories:

- G-R Hard Iron Impeller
- Control Panel (Consult [SF Series Motor Data Reference](#) for Customer-Supplied Control Panel)
- Submersible Transducer or Ball Type Float Switches
- Slide Rail Installation Components
 - Guide shoe w/Rubber Seal
 - Base Elbow and Rail Brackets
- Trash Stand Installation Components
 - Trash Stand
 - Discharge Elbow

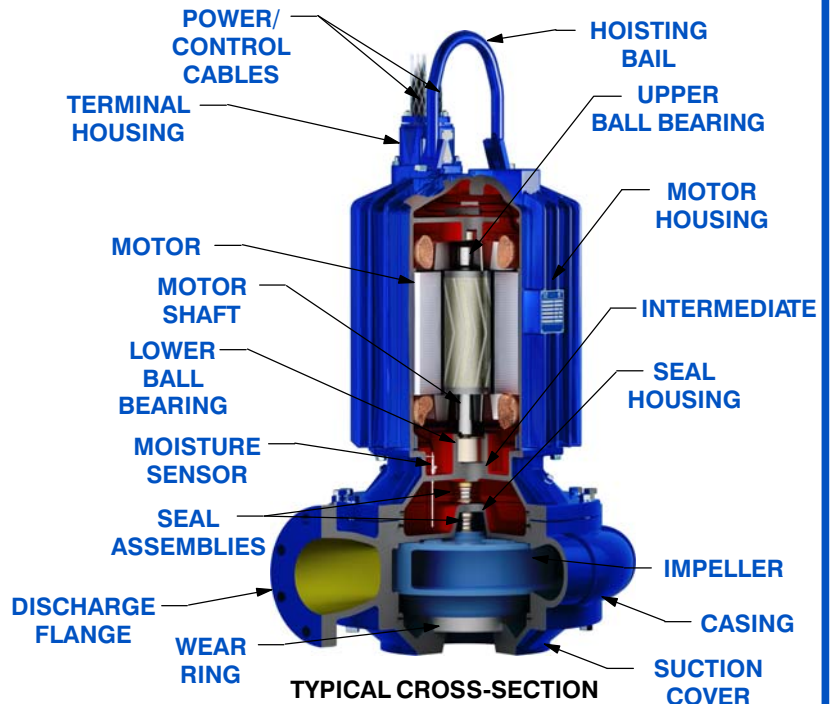

GORMAN-RUPP PUMPS

www.grpumps.com

Specifications Subject to Change Without Notice

Printed in U.S.A.

PUMP DETAILS

Pump Model	SF8B & SF8B-X	
Agency Approvals	Consult Factory	
Discharge Flange	8" ANSI w/ Flat Face	
Impeller Type/Material	Two Vane Enclosed / Ductile Iron	
Wear Ring Material	Ductile Iron	
Spherical Solids Handling	3" (76 mm) Non-Deformable Diameter	
Motor Housing (Including Seal Plate and Intermediate)	Gray Iron 30	
Pump Casing	Ductile Iron	
Motor Shaft	17-4 PH Stainless Steel	
O-Rings	Buna-N and Fluorocarbon (DuPont Viton® or Equivalent)	
Bearings: Type/Lubrication	Upper	Single Row Ball/Permanent Lubrication
	Lower	Double Row Ball/Permanent Lubrication
External Hardware	303/304 Stainless Steel	
External Surface Protection	Epoxy Paint	
Seal Type	Tandem, Mechanical, Oil Lubricated Upper, Self-Lubricated Lower	
Sealing Faces: Rotating/Stationary	Upper	Carbon/Ni-Resist
	Lower	Silicon Carbide/Silicon Carbide
Seal Elastomers	Buna-N Upper, Fluorocarbon (DuPont Viton® or Equivalent) Lower	
Max. Liquid Temperature	104°F (40°C)	

MOTOR DETAILS

Speed	60 Hz, 1750 RPM	
Motor Design	Inverter-Duty Rated, Air-Filled Enclosure, Squirrel Cage, Induction Start	
Motor Efficiency Rating	NEMA Premium Efficiency (IEC IE3)	
Insulation	Class H, Rated 356°F (180°C)	
Max. Submergence	65 Feet (20 Meters)	
Min. Submergence	1/2 Motor Covered	
Max. Starts per Hour	10	
Max. Rated Output Power	75.0 HP (55.9 kW)	
Amp Draw @ Max. Rated Power: Full Load/ Locked Rotor		
	460V/3P	86.0/542.0
	575V/3P	69.0/434.0
NEMA Motor Code	G	
Service Factor	1.15	
Efficiency: 100%/75%/50% Load	94%/96%/94%	
Power Factor: 100%/75%/50% Load	0.85/0.81/0.73	
Field Connection	Across-the-Line	
Moisture Sensor	Single Probe Monitoring Both Seal and Motor Chambers	
Thermal Overload	One Thermostat per Phase, Self-Resetting	

CABLE DETAILS

		460V	575V
Power Cable	Voltage	460V	575V
	No. Cables/Conductors per	1/6	1/6
	Gauge	(3) 1 AWG PWR & (3) 6 AWG GND/GC	(3) 1 AWG PWR & (3) 6 AWG GND/GC
	Type/Material	GGC/CPE	GGC/CPE
Nominal Cable O.D.	1.51" (38.4 mm)	1.51" (38.4 mm)	
Control Cable	No. Cables/Conductors per	1/4	
	Gauge	14 AWG	
	Type/Material	SOOW/CPE	
	Nominal Cable O.D.	0.61" (15.5 mm)	
Length	32 Feet (10 Meters) Standard, 164 Feet (50 Meters) Maximum		



GORMAN-RUPP PUMPS

www.grpumps.com

Specifications Subject to Change Without Notice

Printed in U.S.A.

Specification Data

SECTION 133, PAGE 420.2

**MODEL SF8B & SF8B-X
SLIDE RAIL VERSION
APPROXIMATE
DIMENSIONS and WEIGHTS**

NET WT: (pump only)
(comb. cable wt. per meter [3.2 ft.])
SHIPPING WT: (pump only)
CRATE SIZE:

1603 LBS. [727,1 KG.]
3.4 LBS. [1,54 KG.]
1703 LBS. [772,5 KG.]
43.5 CU. FT. [1,23 CU. M.]

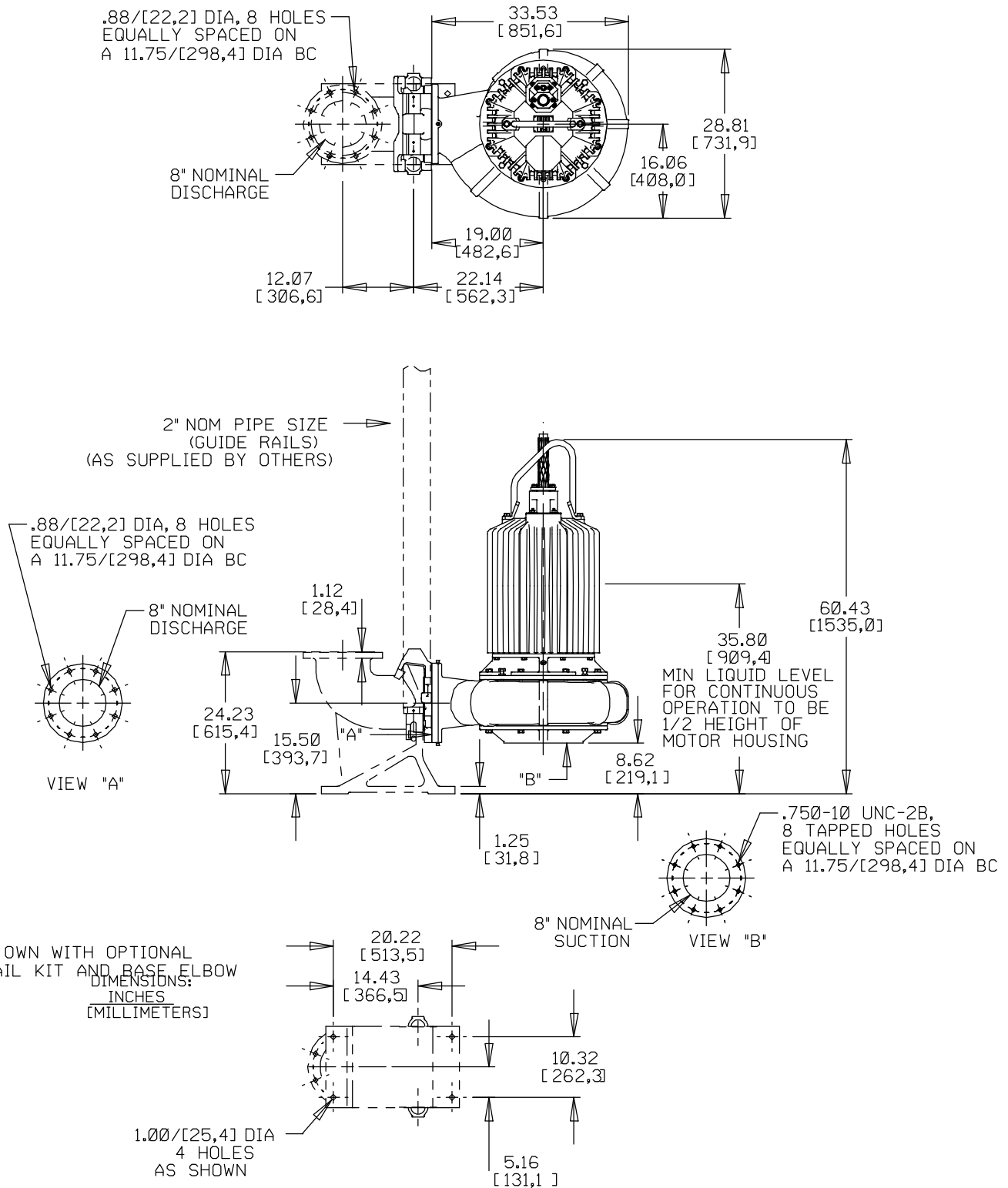

GORMAN-RUPP PUMPS

www.grpumps.com

Specifications Subject to Change Without Notice

Printed in U.S.A.

Specification Data

SECTION 133, PAGE 420.3

**MODEL SF8B & SF8B-X
TRASH VERSION
APPROXIMATE
DIMENSIONS and WEIGHTS**

NET WT: (pump only)
(comb. cable wt. per meter [3.2 ft.])
SHIPPING WT: (pump only)
CRATE SIZE:

1667 LBS. [756,1 KG.]
3.4 LBS. [1,54 KG.]
1767 LBS. [801,5 KG.]
46.4 CU. FT. [1,31 CU. M.]

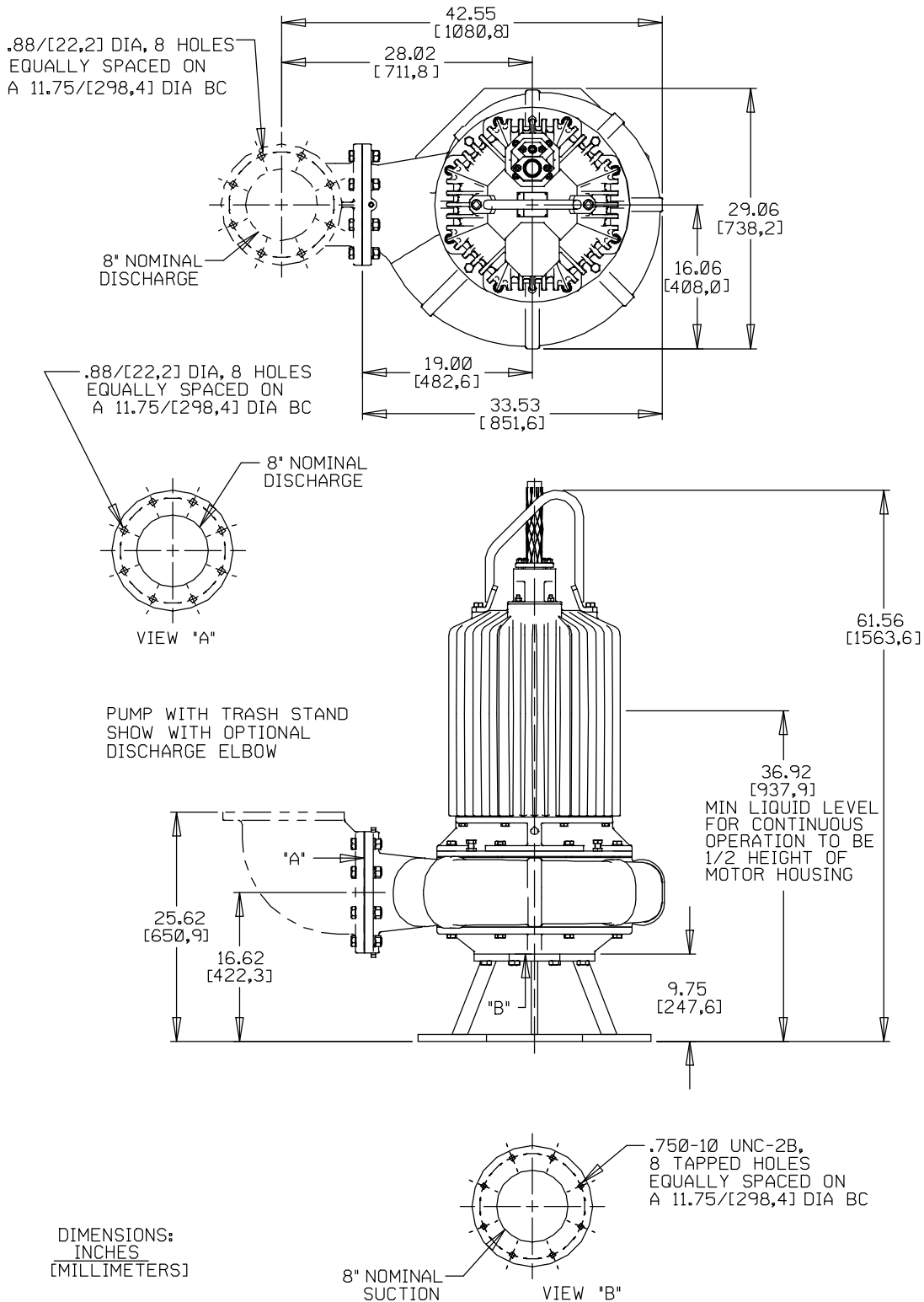

GORMAN-RUPP PUMPS

www.grpumps.com

Specifications Subject to Change Without Notice

Printed in U.S.A.

PERFORMANCE CURVE

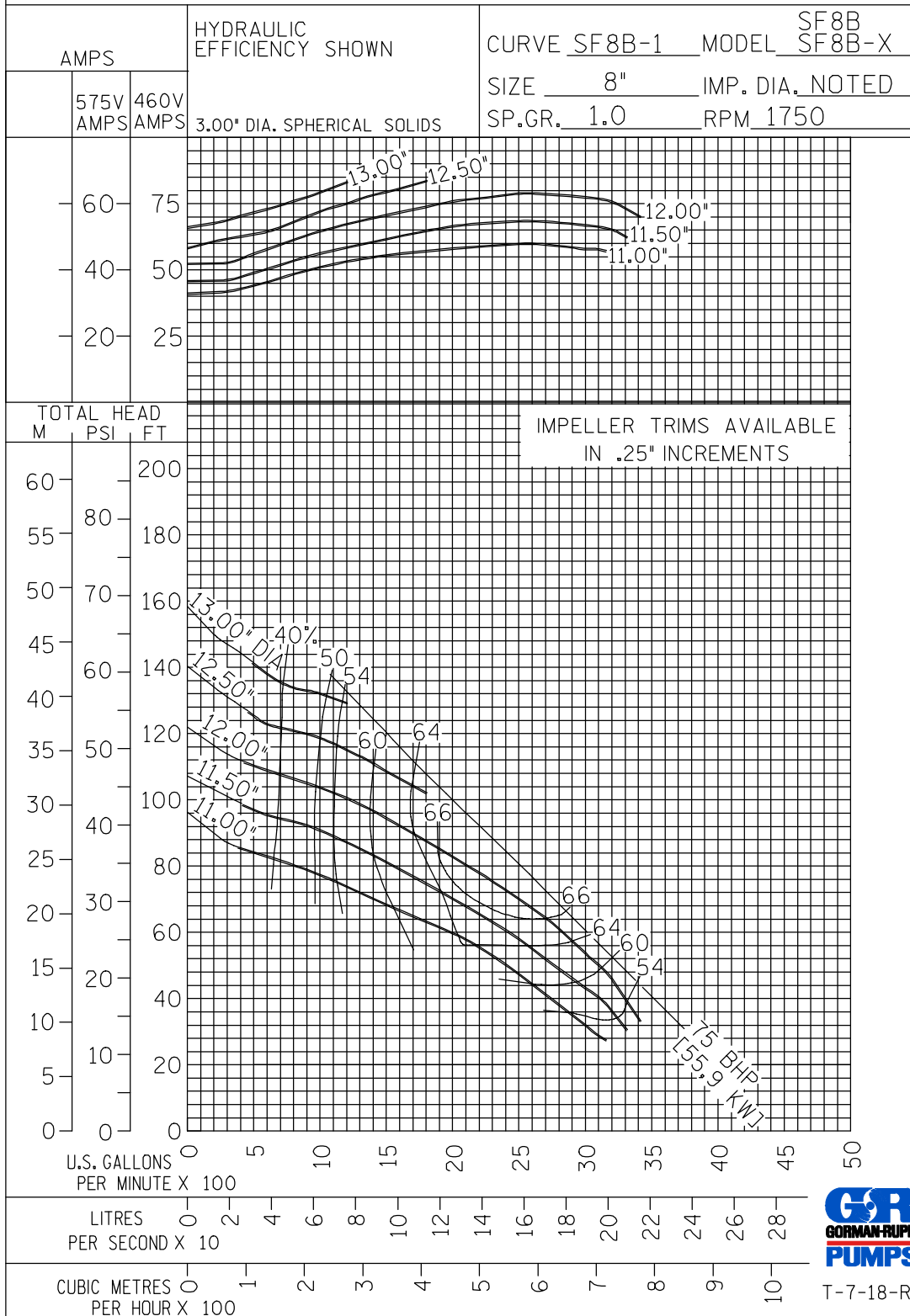

T-7-18-R



GORMAN-RUPP PUMPS

www.grpumps.com

Specifications Subject to Change Without Notice

Printed in U.S.A.