



PORTABLE HYDRAULIC POWER UNIT

Models HSP-L100W FT4 and HSP-GX390

PHOTO NOT AVAILABLE AT
TIME OF PUBLISHING



ENGINE SPECIFICATIONS

Model HSP-L100W FT4

Model: Yanmar L100W Diesel Engine.
EPA Tier: Final Tier 4.
Type: Single Cylinder, Vertical Four Cycle, Air Cooled.
Displacement: 26.5 Cu. In. (435 cc).
Lubrication: Forced Circulation.
Air Cleaner: Dry Type w/Paper Element.
Fuel Tank: 1.24 U.S. Gallons (4,7 L).
Standard Features: Electric Start.

YANMAR PUBLISHED PERFORMANCE:
 Maximum Gross HP 9.1 (6,8 kW) @ 3600 RPM

Model HSP-GX390

Model: Honda GX390 Gasoline Engine.
Type: Single Cylinder, Four Cycle, Overhead Valve, Air Cooled.
Displacement: 23.7 Cu. In. (389 cc).
Lubrication: Splash.
Air Cleaner: Oil Bath.
Fuel Tank: 1.72 U.S. Gallons (6.5 L).
Standard Features:
 Safety Shut Down Switch for Low Oil Pressure.

HYDRAULIC SPECIFICATIONS

Hose Ports: 1/2" (12,7 MM) Hydraulic Tool Manufacturer's Association (H.T.M.A.) Quick Disconnect.

Hydraulic Pump: Fixed Displacement Gear Type.

Hydraulic Output: Variable, 6 GPM Max (1363 LPH).

Max. Operating Pressure:

Model HSP-L100W FT4 1800 PSI (12411 kPa).

Model HSP-GX390 2100 PSI (14479 kPa).

Hydraulic Oil: Biodegradable Hydraulic Oil.

Hydraulic Oil Reservoir Capacity: 4 U.S. Gallons (15 L).

Standard Equipment: Tank Mounted Oil Cooler. Roll Cage Base With Lifting Eye. Wheel Kit. Pressure Control Valve. System Relief Valve. Spin on Return Filter. Fluid Level Gauge. Tank Top Filler/ Strainer. Variable Speed Control. Liquid Filled Pressure Gauge.

Optional Equipment: 1/2" [12,7 MM] Hydraulic Hoses with H.T.M.A. Quick Disconnect Fittings.*

* Hydraulic Hose Available in 50 Foot [15,2 Meter] Increments.
 Maximum Recommended Length 150 Feet [45,7 Meters]. Specify Length at Time of Order.



GORMAN-RUPP PUMPS

www.grpumps.com

Specifications Subject to Change Without Notice

Printed in U.S.A.

Specification Data

APPROXIMATE
DIMENSIONS and WEIGHTS

NET WEIGHT: 228 LBS. (103 KG.)
SHIPPING WEIGHT: 268 LBS. (122 KG.)
EXPORT CRATE: 46 CU. FT. (1,3 CU. M.)

SECTION 140, PAGE 1400

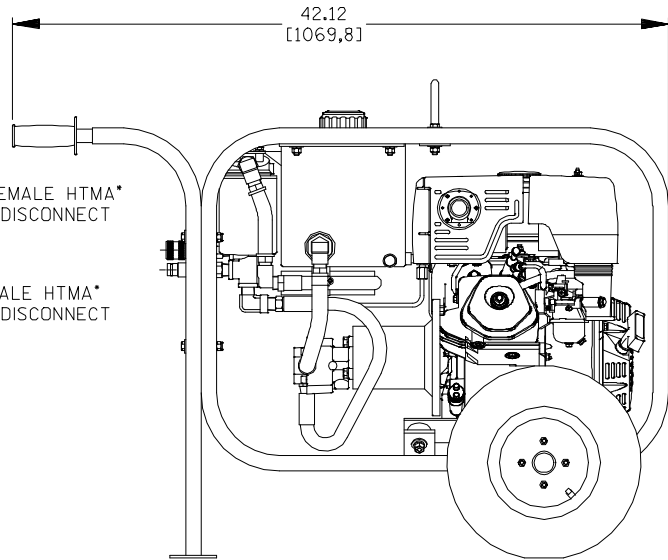
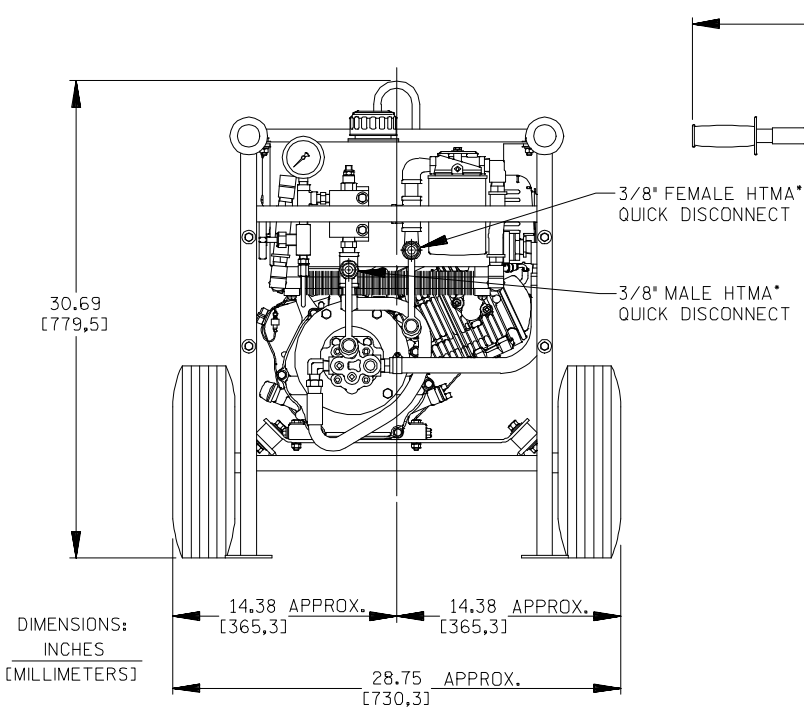

* HYDRAULIC TOOL MANUFACTURER'S ASSOCIATION.
POWERED BY HONDA GX-390 ENGINE.

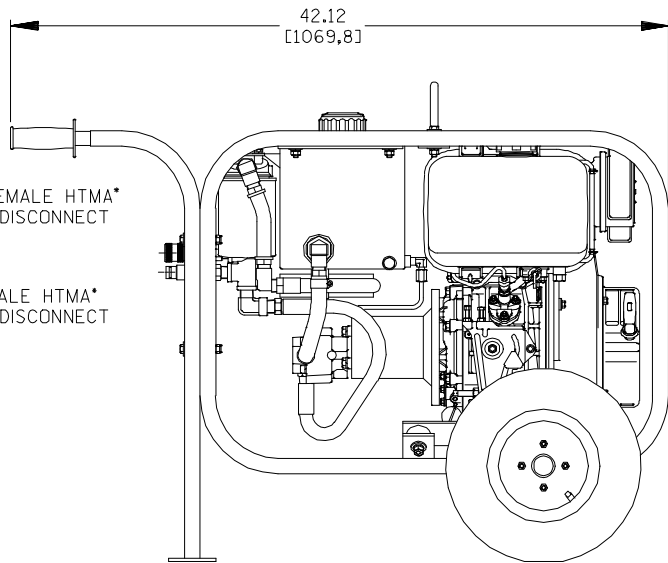
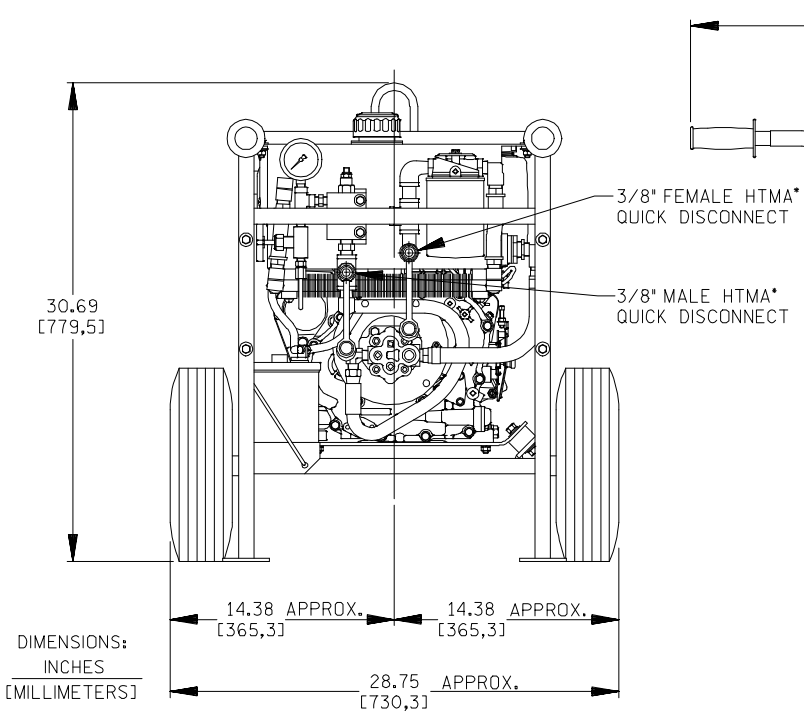

* HYDRAULIC TOOL MANUFACTURER'S ASSOCIATION.
POWERED BY YANMAR L100W ENGINE.



GORMAN-RUPP PUMPS

www.grpumps.com

Specifications Subject to Change Without Notice

Printed in U.S.A.