

GHC SERIES HEAVY DUTY COMPACT STAINLESS STEEL ROTARY GEAR PUMP

This heavy duty series with internal “wetted” parts of 316 Stainless Steel is ideal for handling corrosive applications. Superior rotor shaft support and an integral maintenance-free radial/thrust bearing, reduce deflection and wear. Due to the “galling” nature of stainless, extra internal clearance is necessary. A capacity correction table for liquids less than 750 SSU is available in Section 500.

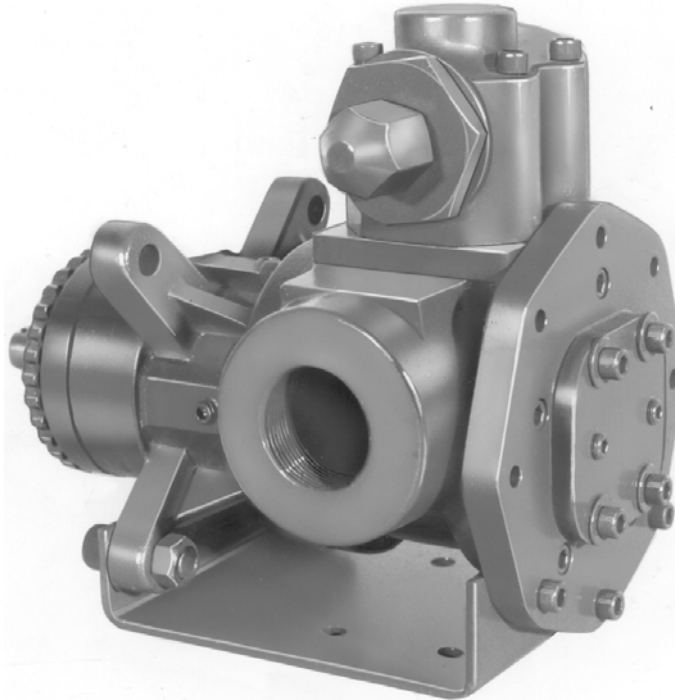

SHOWN ^W/OPTIONAL THREADED PORTS

The GHC stainless series is designed for applications in the operating ranges noted on the model pages. These units are available with head jackets for temperature control, silicon carbide bushings for wear resistance, and numerous shaft seal options described on the following pages. These units may be foot mounted or, by using a motor adaptor, direct connected to NEMA “C” flange motors.

FEATURES

- 200 PSI CAPABILITY
- BALL BEARING THRUST CONTROL
- ROTOR END CLEARANCE EXTERNALLY ADJUSTABLE
- EXCEPTIONAL SEAL VERSATILITY WITH INTERNAL SEAL VENT
- COMPUTER PROFILED GEARING FOR QUIET OPERATION
- MULTIPLE PORT POSITIONS

OPERATING RANGE

CAPACITY	(GPM):	(3 TO 107)
	[LPM]:	[11 TO 405]
PRESSURE	(PSI):	[0 TO 200]
	[BAR]:	[0 TO 14]
VISCOSITY	(SSU):	(28 TO 25,000)
	[cSt]:	[1 TO 5417]
TEMPERATURE (F)	:	(-30° TO 350°)
	[C]:	[-34° TO 177°]

APPLICATIONS

USE WITH ANY CLEAN LIQUID COMPATIBLE WITH 316 STAINLESS STEEL

- ★ BOOSTER SERVICE
- ★ CIRCULATING
- ★ FILTERING
- ★ LUBRICATING
- ★ TRANSFERRING

EXTERIOR	BACKHD	ROTOR & IDLER	HOUSING PORTS	BUSHING	IDLER PIN	SHAFT	SHAFT SEALING		ROTA-TION	INTERNAL RELIEF VALVE	
							MECH. SEAL	PACKING		MATERIAL	SETTING
316 STAIN. STEEL	CAST IRON	316 STAIN. STEEL	GHC 180° FLG. GHS 90° NPT	CARBON GRAPHITE	COATED 316 SST	STAIN. STEEL	CARBON, SIC, TEFLON ENC.	CARBON FIBER	C.W.	316 STAINLESS STEEL	75 PSI [5 BAR]

G H C 1 DC 9 - B
G H S 1 DC 9 - B
 | | | | | | | | | | | |
 GEAR DUTY DESIGN PORT SIZE HYD. SIZE SEAL STYLE

Standard Models

MODEL NUMBER		NOM. CAPACITY - SPEED				MAXIMUM				SHIPPING DATA	
		MAXIMUM		ALTERNATIVE		DIFF. PRESSURE - PSI [BAR]			TEMP.		
		GPM [LPM]	RPM 60 Hz [50 HZ]	GPM [LPM]	RPM 60 Hz [50 HZ]	BELOW 38 SSU [4 cSt]	38 TO 100 SSU [21 cSt]	100 TO 250,000 SSU [55,000 cSt]	°F [°C]	Wt. [LBS [KG]]	Vol. [CU. FT.]
GHC 1 DC9-B ① ● ▸	GHS 1 DC9-B ① ●	9 [28]	1750 [1460]	6 [19]	1150 [960]	75 [5]	100 [7]	200 [14]	GHC ● 350 [177]	32 [14,5]	2.9
	GHS 1 DC10-B ① ■			7 [22]						32 [14,5]	
GHC 1 DE9-B ① ● ▸	GHS 1 DE9-B ① ●	11 [35]	1750 [1460]	7 [22]	1150 [960]	75 [5]	100 [7]	200 [14]	GHC ● 350 [177]	32 [14,5]	2.9
	GHS 1 DE10-B ① ■			10 [32]						63 [28,6]	
GHC 1-1/2 GC9-B ● ▸	GHS 1-1/2 GC9-B ●	16 [50]	1750 [1460]	10 [32]	1150 [960]	75 [5]	100 [7]	200 [14]	GHC ● 350 [177]	63 [28,6]	2.9
	GHS 1-1/2 GC10-B ■			15 [47]						63 [28,6]	
GHC 1-1/2 GF9-B ● ▸	GHS 1-1/2 GF9-B ●	23 [73]	1750 [1460]	15 [47]	1150 [960]	75 [5]	100 [7]	200 [14]	GHC ● 350 [177]	63 [28,6]	2.9
	GHS 1-1/2 GF10-B ■			20 [63]						63 [28,6]	
GHC 1-1/2 GH9-B ● ▸	GHS 1-1/2 GH9-B ●	31 [98]	1750 [1460]	20 [63]	1150 [960]	75 [5]	100 [7]	200 [14]	GHC ● 350 [177]	63 [28,6]	2.9
	GHS 1-1/2 GH10-B ■			25 [79]						63 [28,6]	
GHC 1-1/2 GJ9-B ● ▸	GHS 1-1/2 GJ9-B ●	38 [120]	1750 [1460]	25 [79]	1150 [960]	75 [5]	100 [7]	200 [14]	GHC ● 350 [177]	63 [28,6]	2.9
	GHS 1-1/2 GJ10-B ■			30 [95]						63 [28,6]	
GHC 1-1/2 GJ9-B ● ▸	GHS 1-1/2 GJ9-B ●	40 [126]	1150 [960]	30 [95]	870 [725]	75 [5]	100 [7]	200 [14]	GHC ● 350 [177]	161 [73,2]	5.3
	GHS 1-1/2 GJ10-B ■			42 [133]						161 [73,2]	
GHC 3 JG9-B ● ▸	GHS 3 JG9-B ●	56 [177]	1150 [960]	42 [133]	870 [725]	75 [5]	100 [7]	200 [14]	GHC ● 350 [177]	161 [73,2]	5.3
	GHS 3 JG10-B ■			56 [177]						161 [73,2]	
GHC 3 JJ9-B ● ▸	GHS 3 JJ9-B ●	56 [177]	1150 [960]	56 [177]	870 [725]	75 [5]	100 [7]	200 [14]	GHC ● 350 [177]	161 [73,2]	5.3
	GHS 3 JJ10-B ■			56 [177]						161 [73,2]	

STANDARD MODELS CONTINUED

① 3450 [2875] RPM PERMISSIBLE TO 1,000 SSU [220 cSt.] AND 100 PSI [7 BAR]

● MECHANICAL SEAL
 ■ PACKING/LIP SEAL

▸ PORTS ARE COMPATIBLE WITH 150# ANSI FLANGES. ALL OTHER PORTS ARE TAPPED NPT FOR ANSI PIPE. OPTIONAL [DIN] FLANGES OR TAPPED [BSP] PORTS ARE AVAILABLE FOR EXPORT MARKET.

NOTE: RECOMMENDED PORT SIZES ARE SHOWN IN **BOLDFACE**. EXAMPLE: **GHC 1 DC9-B**, **GHS 1 DC9-B**

THE GORMAN-RUPP COMPANY • MANSFIELD, OHIO

GORMAN-RUPP OF CANADA LIMITED • ST. THOMAS, ONTARIO, CANADA

Standard Models (Continued)

MODEL NUMBER		NOM. CAPACITY - SPEED				MAXIMUM				SHIPPING DATA	
		MAXIMUM		ALTERNATIVE		DIFF. PRESSURE - PSI [BAR]			TEMP.	Wt.	Vol.
		GPM [LPM]	RPM 60 Hz [50 HZ]	GPM [LPM]	RPM 60 Hz [50 HZ]	BELOW 38 SSU [4 cSt]	38 TO 100 SSU [21 cSt]	100 TO 250,000 SSU [55,000 cSt]	°F [°C]	LBS [KG]	CU. FT.
GHC	GHS 2 JL9-B ●	77 [243]	1150 [960]	58 [133]	870 [725]	75 [5]	100 [7]	200 [14]	161 [73,2]	5.3	
	GHS 2 JL10-B ■										
GHC 3 JL9-B ● †	GHS 3 JL9-B ●	107 [338]	960 [960]	81 [256]	580 [480]	75 [5]	100 [7]	200 [14]	161 [73,2]	5.3	
	GHS 3 JL10-B ■										
GHC 3 JP9-B ● †	GHS 2 JP9-B ●	132 [500]	960 [960]	80 [252]	580 [480]	75 [5]	100 [7]	200 [14]	161 [73,2]	5.3	
	GHS 2 JP10-B ■										
GHC 3 JP9-B ● †	GHS 3 JP9-B ●	165 [624]	960 [960]	99 [312]	580 [480]	75 [5]	100 [7]	200 [14]	161 [73,2]	5.3	
	GHS 3 JP10-B ■										
GHC	GHS 2 NK9-B ●	99 [375]	960 [960]	60 [189]	580 [480]	75 [5]	100 [7]	200 [14]	180 [81,8]	5.3	
	GHS 2 NK10-B ■										
GHC 3 NK9-B ●	GHS 2-1/2 NK9-B ●	132 [500]	960 [960]	80 [252]	580 [480]	75 [5]	100 [7]	200 [14]	180 [81,8]	5.3	
	GHS 2-1/2 NK10-B ■										
GHC 3 NK9-B ●	GHS 3 NK9-B ●	165 [624]	960 [960]	99 [312]	580 [480]	75 [5]	100 [7]	200 [14]	180 [81,8]	5.3	
	GHS 3 NK10-B ■										
GHC 3 NM9-B ●	GHS 2 NM9-B ●	172 [542]	960 [960]	115 [362]	580 [480]	75 [5]	100 [7]	200 [14]	180 [81,8]	5.3	
	GHS 2 NM10-B ■										
GHC 3 NM9-B ●	GHS 2-1/2 NM9-B ●	215 [678]	720 [600]	143 [451]	480 [400]	75 [5]	100 [7]	200 [14]	180 [81,8]	5.3	
	GHS 2-1/2 NM10-B ■										
GHC 3 NP9-B ●	GHS 3 NP9-B ●	172 [542]	720 [600]	143 [451]	480 [400]	75 [5]	100 [7]	200 [14]	180 [81,8]	5.3	
	GHS 3 NP10-B ■										
GHC 3 NP9-B ●	GHS 2 RM9-B ●	172 [542]	720 [600]	143 [451]	480 [400]	75 [5]	100 [7]	200 [14]	180 [81,8]	5.3	
	GHS 2 RM10-B ■										
GHC 3 RM9-B ● †	GHS 2-1/2 RM9-B ● †	215 [678]	720 [600]	143 [451]	480 [400]	75 [5]	100 [7]	200 [14]	180 [81,8]	5.3	
	GHS 2-1/2 RM10-B ■ †										
GHC 3 RM9-B ● †	GHS 3 RM9-B ● †	215 [678]	720 [600]	143 [451]	480 [400]	75 [5]	100 [7]	200 [14]	180 [81,8]	5.3	
	GHS 3 RM10-B ■ †										
GHC 3 RP9-B ● †	GHS 4 RM9-B ● †	215 [678]	720 [600]	143 [451]	480 [400]	75 [5]	100 [7]	200 [14]	180 [81,8]	5.3	
	GHS 4 RM10-B ■ †										
GHC 3 RP9-B ● †	GHS 3 RP9-B ● †	215 [678]	720 [600]	143 [451]	480 [400]	75 [5]	100 [7]	200 [14]	180 [81,8]	5.3	
	GHS 3 RP10-B ■ †										
GHC 3 RP9-B ● †	GHS 4 RP9-B ● †	215 [678]	720 [600]	143 [451]	480 [400]	75 [5]	100 [7]	200 [14]	180 [81,8]	5.3	
	GHS 4 RP10-B ■ †										

STANDARD MODELS CONTINUED

- MECHANICAL SEAL
- PACKING/LIP SEAL

† PORTS ARE COMPATIBLE WITH 150# ANSI FLANGES. ALL OTHER PORTS ARE TAPPED NPT FOR ANSI PIPE. OPTIONAL [DIN] FLANGES OR TAPPED [BSP] PORTS ARE AVAILABLE FOR EXPORT MARKET.

NOTE: RECOMMENDED PORT SIZES ARE SHOWN IN **BOLDFACE**. EXAMPLE: **GHC 1 DC9-B, GHS 1 DC9-B**

THE GORMAN-RUPP COMPANY • MANSFIELD, OHIO
 GORMAN-RUPP OF CANADA LIMITED • ST. THOMAS, ONTARIO, CANADA

MODEL NUMBER		NOM. CAPACITY - SPEED				MAXIMUM				SHIPPING DATA	
		MAXIMUM		ALTERNATIVE		DIFF. PRESSURE - PSI [BAR]			TEMP.	Wt.	Vol.
		GPM [LPM]	RPM 60 Hz [50 HZ]	GPM [LPM]	RPM 60 Hz [50 HZ]	BELOW 38 SSU [4 cSt]	38 TO 100 SSU [21 cSt]	100 TO 250,000 SSU [55,000 cSt]	°F [°C]	LBS [KG]	CU. FT.
GHC	GHS										
	GHS 3 RR9-B ● ▸ GHS 3 RR10-B ■ ▸	255 [804]	720 [600]	170 [536]	480 [400]	75 [5]	100 [7]	200 [14]	GHS ● 400 [204] ■ 500 [260]	357 [162]	10.7
	GHS 4 RR9-B ● ▸ GHS 4 RR10-B ■ ▸			196 [618]						357 [162]	
	GHS 4 RS9-B ● ▸ GHS 4 RS10-B ■ ▸			295 [930]						357 [162]	

▸ PORTS ARE COMPATIBLE WITH 150# ANSI STAINLESS STEEL FLANGES. ALL OTHER PORTS ARE TAPPED NPT FOR ANSI PIPE. OPTIONAL [DIN] FLANGES OR TAPPED [BSP] PORTS AVAILABLE FOR EXPORT MARKET.

NOTE: RECOMMENDED PORT SIZES ARE SHOWN IN BOLDFACE. EXAMPLE: **GHC 1 DC9-B, GHS 1 DC9-B**

APPLICATION RECOMMENDATIONS:		
APPLICATION	OPTIONS REQUIRED (Select One From Each Row)	OPERATING LIMITATIONS
GHS ONLY HIGH TEMPERATURE	25U, 25V, OR 25W 35J – 35M (AS REQ'D) 40R, 70K 61H OR 65Q	TEMPERATURE: 675 °F MAX. PRESSURE: 200 PSI MAX.
GHS ONLY JACKETED	40K, 40W, 41U, 41W	LIMIT JACKET PRESSURE TO 150 PSI

NOTE: PROPER PUMP APPLICATION REQUIRES CONSIDERATION OF ADDITIONAL FACTORS. PLEASE REVIEW APPLICATION GUIDE IN SECTION 500 OR CONSULT THE FACTORY.

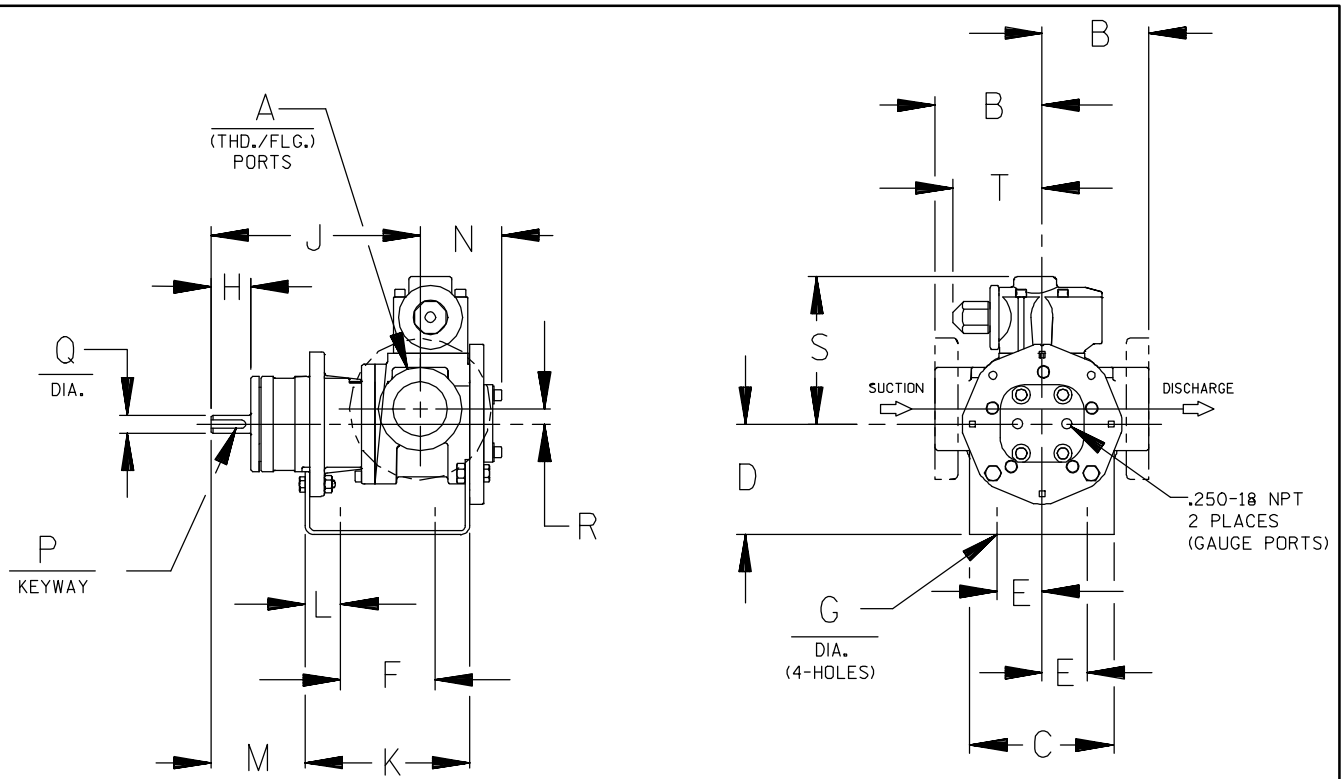

CAD FILE NO.: 16458B

MODEL NUMBERS	PUMP DIMENSIONS - INCHES [MILLIMETERS]																	
	A	B	C	D	E	F	G	H	J	K	L	M	N	P	Q	R	S	T
GHC D	1"	2.50 [64] †	4.00 [102]	3.50* [89]	1.62 [41]	3.12 [79]	.41 [10]	1.16 [30]	6.19 [157]	5.04 [128]	.76 [19]	2.62 [66]	2.74 [70]	.12 [3]	.50 [13]	.62 [16]	5.19 [132]	3.58 [91]
		4.00* [102] †		5.25 [133]										.75 [19]				
GHC G	1-1/2"	3.50 [89] †	5.88 [149]	3.50* [89]	1.62 [41]	4.00 [102]	.41 [10]	1.62 [41]	8.50 [216]	6.71 [170]	1.06 [27]	3.82 [97]	3.35 [85]	.19 [5]	.75 [19]	.62 [16]	6.00 [152]	3.62 [92]
		4.00* [102] †		4.50 [114]										5.25 [133]				
GHC J	3"	4.50 [114] †	6.88 [175]	4.50 [114]	2.88 [73]	4.25 [108]	.44 [11]	2.50 [64]	12.12 [308]	9.75 [248]	1.75 [44]	5.50 [140]	4.66 [118]	.25 [6]	1.00 [25]	1.12 [28]	9.06 [230]	6.75 [171]
		6.00* [152] †		5.25* [133]										6.25 [159]				

* STANDARD DIMENSION

† PORTS ARE COMPATIBLE WITH 125* OR 250* ANSI CAST IRON FLANGES. ALL OTHER PORTS ARE TAPPED NPT FOR ANSI PIPE. OPTIONAL (DIN) FLANGES OR TAPPED (BSP) PORTS AVAILABLE FOR EXPORT MARKET.

† 90° HOUSING

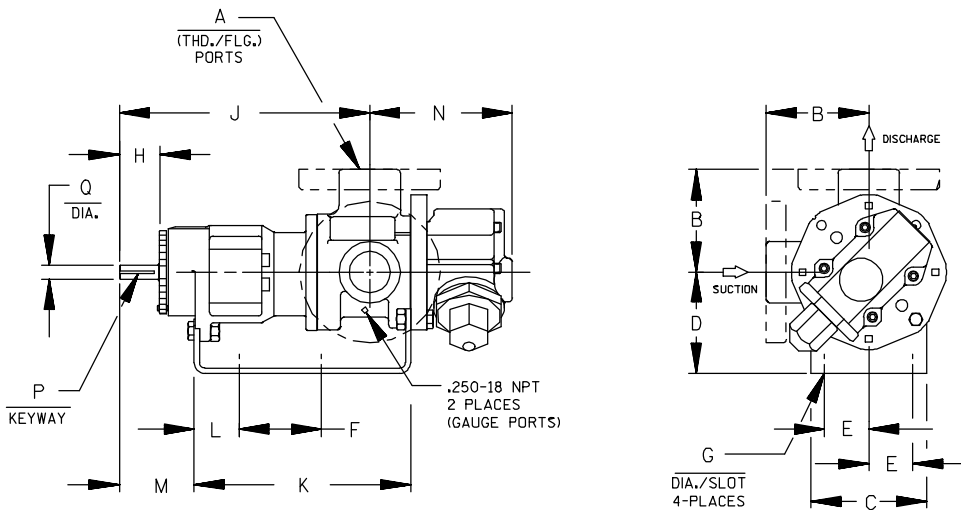

CAD FILE NO.: 16669G

MODEL NUMBERS	PUMP DIMENSIONS - INCHES [MILLIMETERS]														
	A	B	C	D	E	F	G	H	J	K	L	M	N	P	Q
GHS D	1"	2.50* [641]	4.00 [102]	3.50* [891]	1.62 [41]	5.50 [140]	.41 [10]	1.16 [30]	8.43 [214]	7.54 [192]	1.09 [28]	2.29 [58]	4.98 [127]	.12 [3] x .75 [19]	.50 [13]
		4.00 † [102]		5.25 [133]											
GHS G	1-1/2" 2"	3.50* [891]	4.88 [124]	3.50* [891]	1.62 [41]	8.00 [203]	.41 [10]	1.62 [41]	12.06 [306]	10.72 [272]	1.52 [39]	3.35 [85]	5.70 [145]	.19 [5] x 1.25 [32]	.75 [19]
		4.00 † [102]		5.25 [133]											
GHS J	2" 3"	4.50* [114]	6.88 [175]	5.25* [133]	2.88 [73]	10.00 [254]	.44 [11]	2.50 [64]	15.68 [398]	14.31 [363]	2.77 [70]	4.48 [114]	8.50 [216]	.25 [6] x 2.00 [51]	1.00 [25]
		6.00 † [152]		6.25 [159]											
GHS N	2" 3"	5.12 [130]	8.00 [203]	4.50 [114]	2.88 [73]	10.00 [254]	.44 [11]	2.58 [66]	16.37 [416]	15.14 [385]	2.69 [68]	4.56 [116]	8.72 [221]	.25 [6] x 2.00 [51]	1.12 [28]
				5.25* [133]											
GHS R	2"	6.50 [165]	10.50 [267]	7.00 [178]	3.75 [95]	13.75 [349]	.52 [13]	2.25 [57]	17.87 [454]	17.36 [441]	1.86 [47]	4.70 [119]	11.31 [287]	.38 [10] x 1.88 [48]	1.44 [37]
	2-1/2"														
	3"														
	4"	7.19 † [183]													

* STANDARD DIMENSION

† PORTS ARE COMPATIBLE WITH 150# OR 300# ANSISTAINLESS STEEL FLANGES. ALL OTHER PORTS ARE TAPPED NPT FOR ANSI PIPE. OPTIONAL (DIN) FLANGES OR TAPPED (BSP) PORTS AVAILABLE FOR EXPORT MARKET.

‡ 180° HOUSING

GHC/GHS

FOR GHC DRIVE OPTIONS

AND DIMENSIONS

SEE SECTION 540

FOR GHS DRIVE OPTIONS

AND DIMENSIONS

SEE SECTION 545

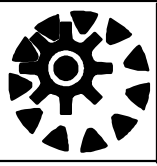

PERFORMANCE CURVES

SPEED VS. CAPACITY/HORSEPOWER

GF Hydraulic Size

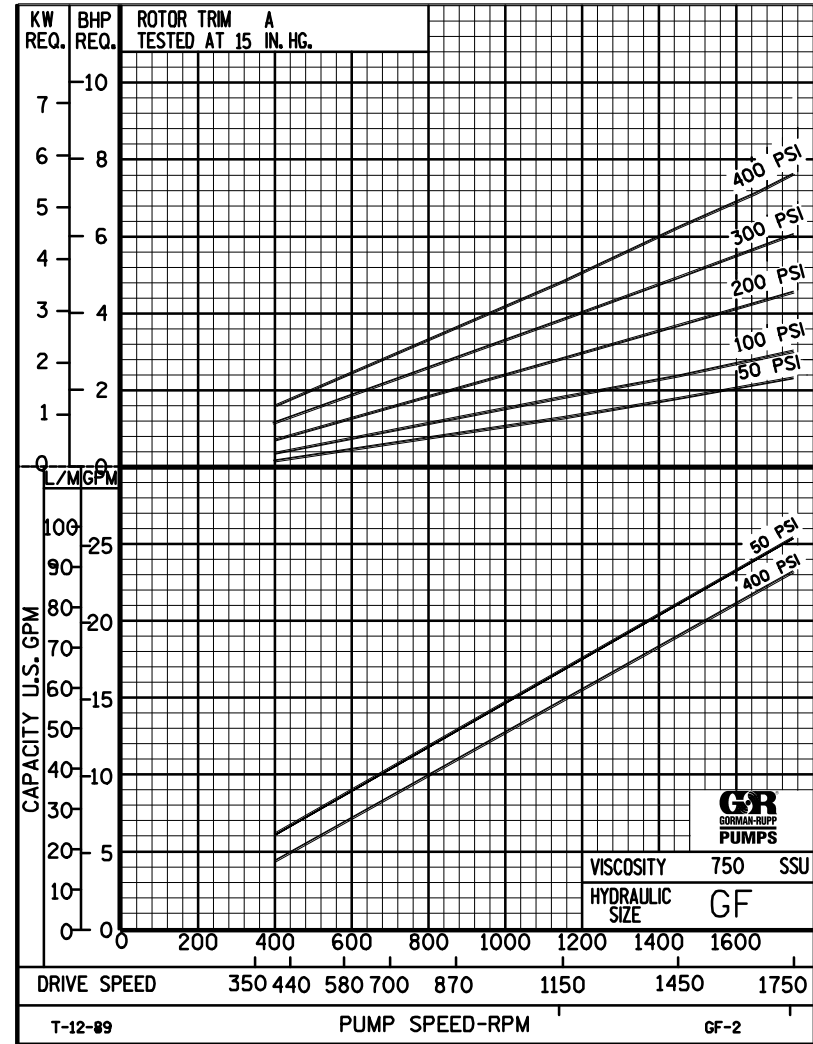
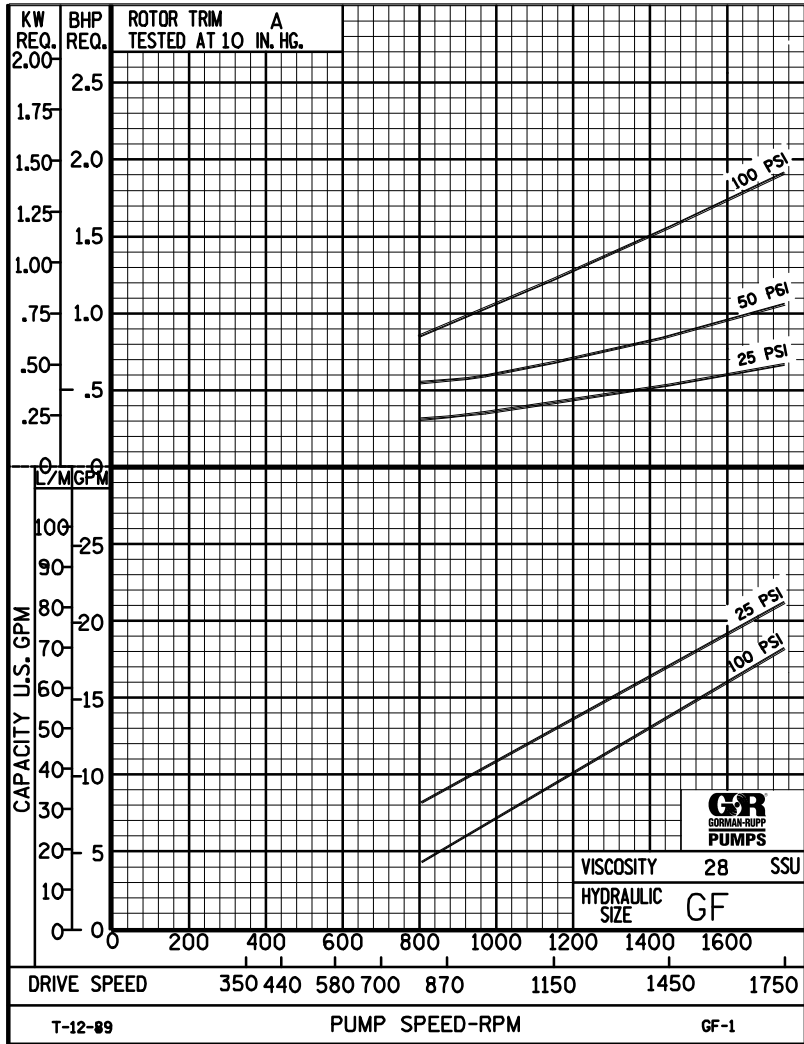

THE GORMAN-RUPP COMPANY • MANSFIELD, OHIO
 GORMAN-RUPP OF CANADA LIMITED • ST. THOMAS, ONTARIO, CANADA

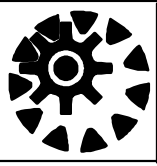

PERFORMANCE CURVES

SPEED VS. CAPACITY/HORSEPOWER

GF Hydraulic Size

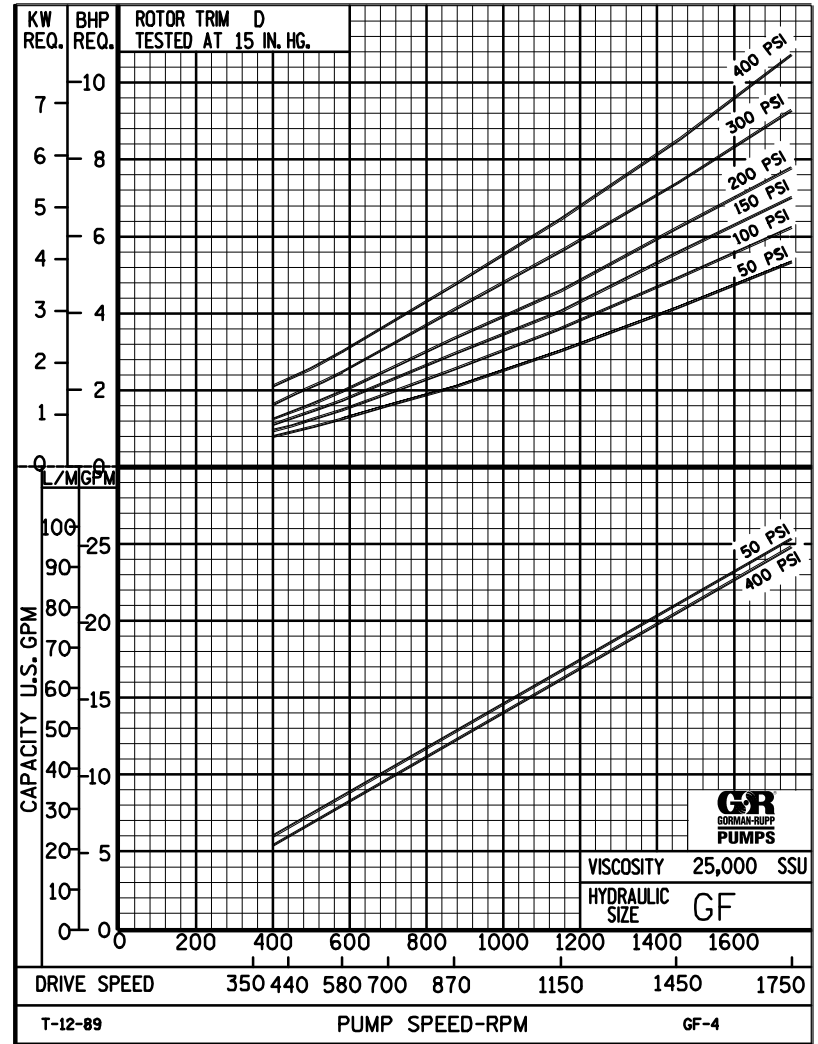
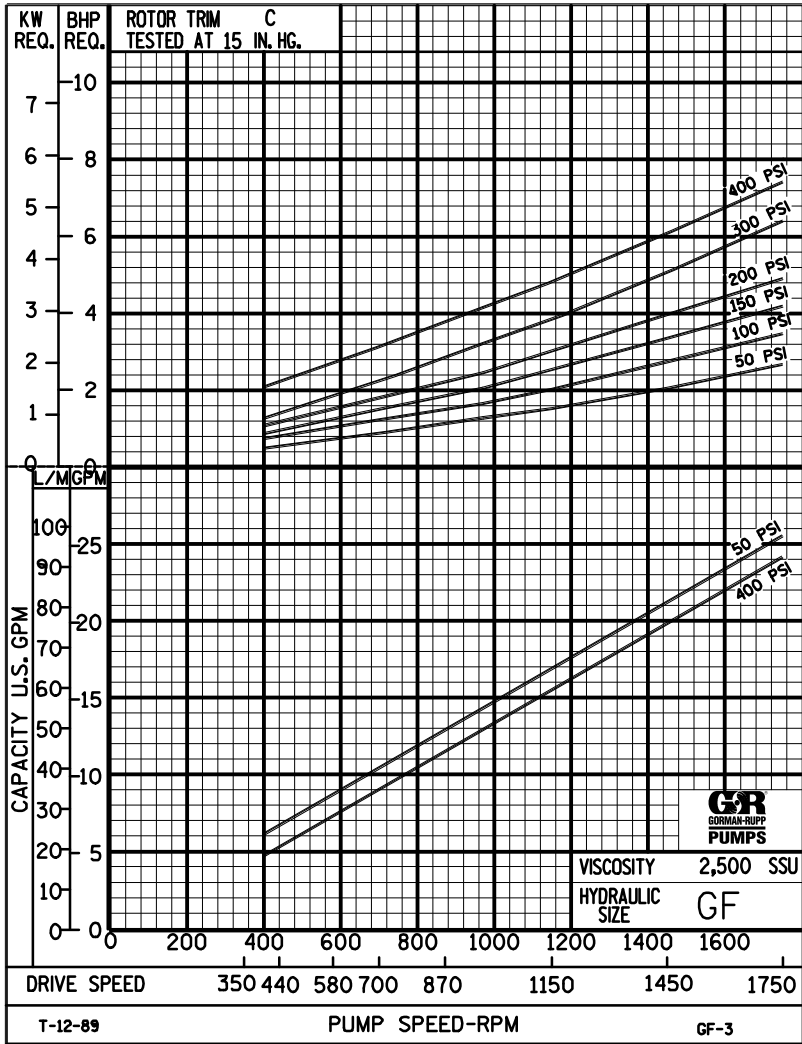

THE GORMAN-RUPP COMPANY • MANSFIELD, OHIO
 GORMAN-RUPP OF CANADA LIMITED • ST. THOMAS, ONTARIO, CANADA



GF

PUMP HYDRAULIC SIZE CHART

SEC. 500

Page 46

January 2010

**23 GPM
1750 RPM**

NOMINAL		ROTOR TRIM	VISCOSITY (SSU)	N.I.P.R. (PSIA)	FRICTION PIPE LOSS (PSI/FT) <small>(Based on Sch 40 Steel Pipe)</small>					FULL BYPASS RELIEF VALVE PRESSURE (PSI)					CAPACITY (GPM) / H.P. REQUIRED															
CAP. GPM	SPEED RPM				PIPE DIAMETER					CRACKING PRESS. (PSI)					DIFFERENTIAL PRESSURE (PSI)															
					3/4"	1"	1 1/4"	1 1/2"	2"	LOW PRES R/V			HI PRES R/V		MEDIUM DUTY AND HEAVY DUTY				HEAVY DUTY ONLY											
23	1750	STD	28	3.9	.01	.01	.01	.01	.01	63	89	117				21	20	19	18											
			32		.36	.12	.03	.02	.01							.69	1.1	1.5	1.9											
			38	3.9	.46	.15	.04	.02	.01	63	89	117	167				22	21	21	19	18									
			50		.56	.18	.05	.03	.01								.92	1.1	1.7	2.1	2.9									
			70	3.9	.63	.20	.06	.03	.01	64	90	119	167	230			23	23	22	21	20	20								
			100		.74	.24	.07	.03	.01								1.1	1.4	1.8	2.2	3.1	3.8								
			150	3.9	.83	.27	.08	.04	.01	64	90	119	167	230			24	24	23	22	22	22	21	19						
			200		.87	.31	.10	.05	.02								1.4	1.6	2.1	2.4	3.2	3.9	5.3	6.6						
			300	3.9	.90	.34	.12	.06	.03	65	91	123	167	230			25	24	24	23	23	23	22	21						
			500		1.47	.56	.19	.10	.04								1.6	1.9	2.4	2.7	3.4	4.2	5.6	6.9						
		750	3.9	2.20	.84	.28	.15	.06	65	91	123	167	230			25	25	25	24	24	24	24	23							
		1,000		2.94	1.12	.38	.20	.08								1.8	2.2	2.7	3.0	3.7	4.4	5.8	7.1							
		2,000	5.0	5.87	2.24	.75	.40	.15	69	97	124	168	232			25	25	25	25	25	24	24	24							
		3,500		10.3	3.91	1.31	.71	.26								2.4	2.9	3.6	3.7	4.4	4.9	6.4	7.6							
		5,000	5.8	14.7	5.59	1.87	1.01	.37	74	100	127	170	233			25	25	25	25	25	24	24	24							
		7,500		22.0	8.40	2.80	1.51	.56								3.1	3.4	4.1	4.4	5.1	5.8	7.3	8.3							
		10,000	6.5	29.4	11.2	3.73	2.01	.74	79	104	130	172	233			25	25	25	25	25	25	24	24							
		15,000		44.0	16.8	5.60	3.02	1.11								3.7	4.1	4.6	5.2	5.9	6.6	8.2	9.3							
		20,000	7.1	58.7	22.4	7.46	4.03	1.48	84	109	134	175	234			25	25	25	25	25	25	24	24							
		25,000		73.4	28.0	9.32	5.03	1.85								4.2	4.6	5.5	6.2	7.0	7.8	9.3	11							
50,000																														
75,000																														
100,000																														
150,000																														
200,000																														
250,000																														

(NOTE) For speeds not shown on the pump hydraulic charts, consult factory.

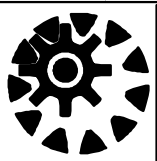

GF

PUMP HYDRAULIC SIZE CHART

SEC. 500

Page 47

January 2010

**15 GPM
1150 RPM**

NOMINAL		ROTOR TRIM	VISCOSITY (SSU)	N.I.P.R. (PSIA)	FRICTION PIPE LOSS (PSI/FT) <small>(Based on Sch 40 Steel Pipe)</small>					FULL BYPASS RELIEF VALVE PRESSURE (PSI)					CAPACITY (GPM) / H.P. REQUIRED																
CAP. GPM	SPEED RPM				PIPE DIAMETER					CRACKING PRESS. (PSI)					DIFFERENTIAL PRESSURE (PSI)																
					3/4"	1"	1 1/4"	1 1/2"	2"	LOW PRES R/V			HI PRES R/V		25	50	75	100	150	200	300	400									
15	1150	STD	28	2.2	.01	.01	.01	.01	.01	59	86	111				13	11	10	9.5												
			32		.17	.06	.02	.01	.01							.56	.72	.96	1.2												
			38	2.2	.22	.07	.02	.01	.01	59	86	111	161				13	13	11	11	9.5										
			50		.27	.09	.03	.01	.01								.62	.78	1.0	1.3	1.8										
			70	2.2	.30	.10	.03	.01	.01	60	87	113	163	215			14	14	13	12	12	11									
			100		.36	.12	.03	.02	.01								.66	.83	1.1	1.4	1.9	2.4									
			150	2.2	.41	.14	.05	.02	.01	60	87	113	163	217			15	15	14	14	13	13	13	13	13	12					
			200		.46	.18	.06	.03	.01								.78	.98	1.2	1.5	1.9	2.4	3.5	4.6							
			300	2.2	.58	.22	.08	.04	.02	60	87	115	165	219			16	15	15	15	15	14	14	13							
			500		.96	.37	.12	.07	.03								.94	1.2	1.4	1.6	2.1	2.6	3.6	4.7							
			750	2.2	1.44	.55	.18	.10	.04	60	87	115	165	222			16	16	16	16	16	15	15	14							
			1,000		1.92	.73	.25	.13	.05								1.1	1.3	1.5	1.7	2.2	2.7	3.7	4.8							
		2,000	2.8	3.83	1.46	.49	.26	.10	62	90	115	165	222			17	17	16	16	16	16	15	15								
		3,500		6.70	2.55	.85	.46	.17								1.4	1.8	2.0	2.1	2.6	3.1	4.1	5.1								
		5,000	3.2	9.57	3.64	1.22	.66	.24	65	92	117	167	224			17	17	16	16	16	16	16	16								
		7,500		14.4	5.46	1.83	.99	.36								1.6	2.0	2.2	2.4	2.9	3.5	4.4	5.4								
		10,000	3.6	19.1	7.29	2.43	1.31	.49	68	94	119	169	224			17	17	16	16	16	16	16	16								
		15,000		28.7	10.9	3.65	1.97	.73								1.9	2.4	2.7	3.0	3.5	4.0	4.8	5.9								
		20,000	3.9	38.3	14.6	4.87	2.63	.97	72	97	122	172	224			17	17	16	16	16	16	16	16								
		25,000		47.8	18.2	6.08	3.28	1.21								2.2	2.8	3.2	3.5	4.0	4.5	5.3	6.5								
		50,000	6.1	95.7	36.4	12.2	6.56	2.42	77	102	127	177	229			17	16	16	16	16	16	16	16								
		75,000		144	54.6	18.3	9.85	3.63								3.6	4.5	5.1	5.7	6.3	6.8	7.7	8.8								
		100,000																													
		150,000																													
200,000																															
250,000																															

(NOTE) For speeds not shown on the pump hydraulic charts, consult factory.

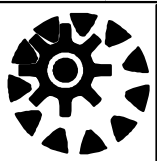

GF

PUMP HYDRAULIC SIZE CHART

SEC. 500

Page 49
January 2010

8 GPM
580 RPM

NOMINAL		ROTOR TRIM	VISCOSITY (SSU)	N.I.P.R. (PSIA)	FRICTION PIPE LOSS (PSI/FT) <small>(Based on Sch 40 Steel Pipe)</small>					FULL BYPASS RELIEF VALVE PRESSURE (PSI)					CAPACITY (GPM) / H.P. REQUIRED											
CAP. GPM	SPEED RPM				PIPE DIAMETER					CRACKING PRESS. (PSI)					DIFFERENTIAL PRESSURE (PSI)											
		3/4"	1"	1 1/4"	1 1/2"	2"	LOW PRES R/V		HI PRES R/V			MEDIUM DUTY AND HEAVY DUTY				HEAVY DUTY ONLY										
						50	75	100	150	200	25	50	75	100	150	200	300	400								
8	580	STD	28	1.1	.01	.01	.01	.01	.01	56	81	106			6	5	4.5	4								
			32		.06	.02	.01	.01	.01							.21	.35	.47	.61							
			38	1.1	.07	.03	.01	.01	.01	56	81	106	157			6.5	6	5.5	4.5	4						
			50		.09	.03	.01	.01	.01							.34	.40	.57	.74	.92						
			70	1.1	.10	.04	.01	.01	.01	56	81	107	158	209		7	6.5	6	6	5.5	4.5					
			100		.10	.04	.01	.01	.01							.36	.42	.59	.76	.98	1.2					
			150	1.1	.15	.05	.02	.01	.01	57	82	108	158	211		7.5	7.5	7	6.5	6.5	6	6	6	5		
			200		.24	.08	.03	.02	.01							.41	.48	.63	.78	1.0	1.2	1.7	2.2			
			300	1.1	.31	.12	.04	.02	.01	57	82	109	159	212		8	8	7.5	7	7	7	6.5	6			
			500		.51	.19	.07	.04	.01							.46	.54	.69	.84	1.1	1.3	1.7	2.3			
			750	1.1	.77	.29	.10	.05	.02	57	82	111	161	214		8.5	8	8	8	8	7	7.5	7			
			1,000		1.02	.39	.14	.07	.03							.53	.62	.76	.89	1.1	1.4	1.7	2.4			
		"C"	2,000	1.5	2.04	.78	.26	.14	.05	58	85	112	162	214		8.5	8.5	8	8	8	8	7.5	7.5			
			3,500		3.57	1.36	.46	.25	.09							.66	.77	.88	.99	1.2	1.5	1.9	2.5			
			5,000	1.9	5.01	1.94	.65	.35	.13	60	85	112	162	214		8.5	8.5	8	8	8	8	8	7.5			
			7,500		7.65	2.91	.97	.53	.19							.84	.99	1.1	1.3	1.5	1.7	2.1	2.7			
			10,000	2.2	10.2	3.88	1.30	.70	.26	63	88	114	166	216		8.5	8.5	8	8	8	8	8	7.5			
			15,000		15.3	5.83	1.95	1.05	.39							1.0	1.2	1.3	1.4	1.6	1.9	2.4	2.9			
			20,000	2.5	20.4	7.77	2.59	1.40	.52	66	91	116	168	218		8.5	8.5	8	8	8	8	8	8			
			25,000		25.5	9.71	3.24	1.75	.65							1.0	1.2	1.4	1.5	1.7	2.0	2.5	3.0			
			50,000	4.0	51.1	19.4	6.50	3.50	1.29	68	93	120	170	222		8.5	8.5	8	8	8	8	8	8			
			75,000		76.5	29.1	9.73	5.25	1.93							1.6	1.9	2.1	2.2	2.4	2.7	3.2	3.7			
			100,000	6.0	102	38.9	13.0	7.00	2.58	70	95	122	172	224		8.5	8	8	8	8	8	8	8			
			150,000		153	58.3	19.5	10.5	3.87							2.1	2.5	2.6	2.7	3.0	3.2	3.7	4.2			
200,000	9.4	204	77.7	26.0	14.0	5.15	76	101	130	180	236		8.5	8.5	8.5	8.5	8	8	8	8						
250,000		-	-	-	-	-							2.5	3.0	3.1	3.2	3.4	3.7	4.2	4.7						

(NOTE) For speeds not shown on the pump hydraulic charts, consult factory.