

SPECIFICATION DATA



STAINLESS STEEL FITTED BASIC SELF-PRIMING CENTRIFUGAL PUMP



Model: T6A61S-B

Various Patents Apply

PUMP SPECIFICATIONS

Size	6" x 6" (152 mm x 152 mm) NPT - Female
Impeller Type	Semi-Open, Two Vane
Solids-Handling Capability	3" (76,2 mm) Spherical Diameter
Seal Type	Mechanical, Oil-Lubricated, Double Floating, Self-Aligning
Radial Bearing	Open Single Row Ball
Thrust Bearing	Open Double Row Ball
Bearing and Seal Cavity Lubrication	SAE 30 Non-Detergent Oil
Maximum Operating Pressure	79 psi (545 kPa)*
Max Temp of Liquid Pumped	160°F (71°C).*

PUMP MATERIALS

Casing	Gray Iron 30
Impeller	Stainless Steel 316
Impeller Shaft	Stainless Steel 17-4 PH
Seal: Stationary Face	Silicon Carbide
Rotating Face	Silicon Carbide
Elastomer	Fluorocarbon FKM, (Viton® or Equivalent)
Replaceable Wear Plate:	Stainless Steel 316
Removable Adjustable Cover Plate	Gray Iron 30
Removable Inspection Cover Plate	Gray Iron 30 – 20 lbs. (9,1 kg.)
Flap Valve	Neoprene with Nylon and Steel Reinforcing
Seal Plate	Stainless Steel 316
Bearing Housing	Gray Iron 30
Flanges	Gray Iron 30
Gaskets	Buna-N, with Compressed Synthetic Fiber, Vegetable Fiber, PTFE, Cork and Rubber
O-Rings	Buna-N
Internal Wetted Hardware	Stainless Steel 316
External Hardware	Standard Plated Steel

*Consult Factory for Applications Exceeding Maximum Pressure and/or Temperature Indicated.

Standard Equipment: Stainless Steel 316 Pressure Relief Valve, Bearing and Seal Cavity Oil Level Sight Gauges.

Optional Equipment: Automatic Air Release Valve, Metal Bellows Seal, Stainless Steel CD4MCu Impeller / Seal Plate & Wear Plate, 120V/240V Casing Heater, Eradicator Solids Reduction System, High Pump Temperature Shutdown Kit, Drain Kit, Gauge Kit.

Gray Iron 30 Suction and Discharge Spool Flanges:
6" ASA (Specify Model T6A61S-B /F)
150 mm DIN 2527 – PN 16 (Specify Model T6A61S-B /FM).



Shown with Optional Suction and Discharge Spool Flanges (Available in ASA or DIN Standard Sizes).

Super T Series Features and Benefits

Easy To Service And Maintain - Pump is mounted above liquid being pumped with only the suction line down in liquid.

Dual Bearing Protection – An atmospheric barrier along with two lip seals provide additional protection of the pump bearings (not available on 2" models).

Inspection Cover – Patented, lightweight inspection cover for easy access to the impeller without removing the entire backcover plate or piping (2" – 8" models).

5 Year Super T Series Warranty

Up To 3" Diameter Spherical Solids Handling (4" – 10" models).

Removable Rotating Assembly – The entire rotating assembly can be removed without disturbing the pump volute or piping allowing the rotating assembly to be easily repaired or quickly replaced with a new ready to drop in assembly.

APPROXIMATE DIMENSIONS AND WEIGHTS

NET WEIGHT	880 LBS. (399 KG.)*
SHIPPING WEIGHT	940 LBS. (426 KG.)*
EXPORT CRATE	32.5 CU. FT. (0,92 CU. M.)

*Add 25 LBS. (11,3 KG.) w/each spool flange

★18.00/[457,2] RECOMMENDED FOR REMOVAL OF BACK COVER PLATE
 T6AS-B / T6CSC-B - 11.00/[279,4] REQUIRED FOR REMOVAL OF BACK COVER PLATE
 T6BS-B / T6DS-B / T6ESC-B / T6FSC-B - 12.00/[304,8] REQUIRED FOR REMOVAL OF BACK COVER PLATE

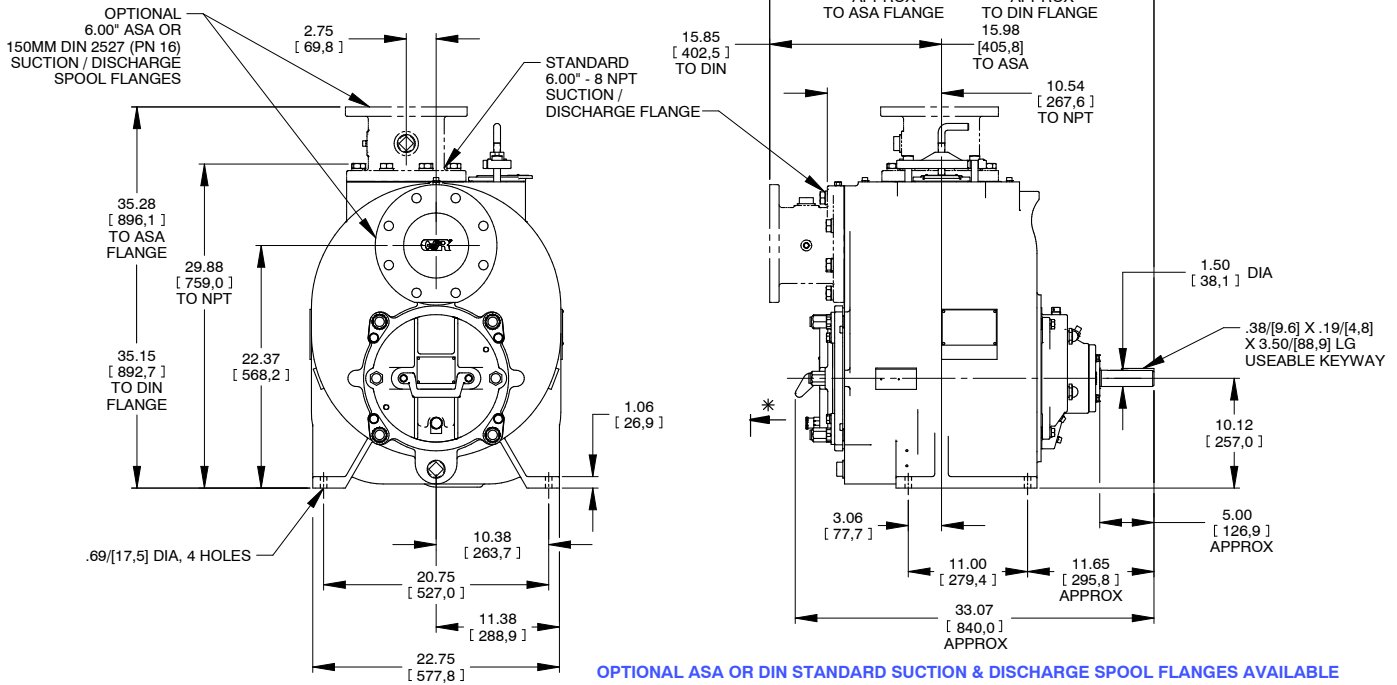

OPTIONAL ASA OR DIN STANDARD SUCTION & DISCHARGE SPOOL FLANGES AVAILABLE

