

**INSTALLATION, OPERATION,  
AND MAINTENANCE MANUAL**  
WITH PARTS LIST



**SUPER T SERIES PUMP**

MODEL
<b>T6A65S-F4L</b>

**THE GORMAN-RUPP COMPANY • MANSFIELD, OHIO**

[www.grpumps.com](http://www.grpumps.com)

GORMAN-RUPP OF CANADA LIMITED • ST. THOMAS, ONTARIO, CANADA Printed in U.S.A.

©2008 The Gorman-Rupp Company

Register your new  
Gorman-Rupp pump online at  
**www.grpumps.com**

Valid serial number and e-mail address required.



**The engine exhaust from this product contains chemicals known to the State of California to cause cancer, birth defects or other reproductive harm.**

### **RECORD YOUR PUMP MODEL AND SERIAL NUMBER**

Please record your pump model and serial number in the spaces provided below. Your Gorman-Rupp distributor needs this information when you require parts or service.

Pump Model: \_\_\_\_\_

Serial Number: \_\_\_\_\_

# TABLE OF CONTENTS

<b>INTRODUCTION</b> .....	<b>PAGE I – 1</b>
<b>SAFETY - SECTION A</b> .....	<b>PAGE A – 1</b>
<b>INSTALLATION – SECTION B</b> .....	<b>PAGE B – 1</b>
Pump Dimensions .....	PAGE B – 1
<b>PREINSTALLATION INSPECTION</b> .....	<b>PAGE B – 2</b>
Battery Specifications And Installation .....	PAGE B – 2
<b>POSITIONING PUMP</b> .....	<b>PAGE B – 2</b>
Lifting .....	PAGE B – 2
Mounting .....	PAGE B – 3
Clearance .....	PAGE B – 3
<b>SUCTION AND DISCHARGE PIPING</b> .....	<b>PAGE B – 3</b>
Materials .....	PAGE B – 3
Line Configuration .....	PAGE B – 3
Connections to Pump .....	PAGE B – 3
Gauges .....	PAGE B – 3
<b>SUCTION LINES</b> .....	<b>PAGE B – 3</b>
Fittings .....	PAGE B – 3
Strainers .....	PAGE B – 4
Sealing .....	PAGE B – 4
Suction Lines In Sumps .....	PAGE B – 4
Suction Line Positioning .....	PAGE B – 4
<b>FLOAT SWITCHES</b> .....	<b>PAGE B – 5</b>
Installation .....	PAGE B – 5
<b>OPTIONAL SUBMERSIBLE TRANSDUCER</b> .....	<b>PAGE B – 6</b>
<b>DISCHARGE LINES</b> .....	<b>PAGE B – 7</b>
Siphoning .....	PAGE B – 7
Valves .....	PAGE B – 7
Bypass Lines .....	PAGE B – 7
<b>AUTOMATIC AIR RELEASE VALVE</b> .....	<b>PAGE B – 8</b>
Theory of Operation .....	PAGE B – 8
Air Release Valve Installation .....	PAGE B – 9
<b>ALIGNMENT</b> .....	<b>PAGE B – 10</b>
<b>OPERATION – SECTION C</b> .....	<b>PAGE C – 1</b>
<b>PRIMING</b> .....	<b>PAGE C – 1</b>
<b>STARTING</b> .....	<b>PAGE C – 2</b>
Manual Starting .....	PAGE C – 2
Automatic Starting .....	PAGE C – 2
<b>OPTIONAL EPS CONTROL</b> .....	<b>PAGE C – 3</b>
Features .....	PAGE C – 3
Functional Description .....	PAGE C – 3
EPS Functions .....	PAGE C – 4
EPS Calibration .....	PAGE C – 4
Zero Adjustment .....	PAGE C – 4
Span Adjustment .....	PAGE C – 5
Level Adjustment .....	PAGE C – 5

**TABLE OF CONTENTS**  
**(continued)**

Horn Delay .....	PAGE C – 5
OPERATION .....	PAGE C – 5
Lines With a Bypass .....	PAGE C – 5
Lines Without a Bypass .....	PAGE C – 5
Leakage .....	PAGE C – 5
Liquid Temperature And Overheating .....	PAGE C – 6
Strainer Check .....	PAGE C – 6
Pump Vacuum Check .....	PAGE C – 6
STOPPING .....	PAGE C – 6
Manual Stopping .....	PAGE C – 6
Automatic Stopping .....	PAGE C – 6
Safety Shutdown System .....	PAGE C – 7
OPERATION IN EXTREME HEAT .....	PAGE C – 7
Cold Weather Preservation .....	PAGE C – 7
BEARING TEMPERATURE CHECK .....	PAGE C – 8
<b>TROUBLESHOOTING – SECTION D .....</b>	<b>PAGE D – 1</b>
PREVENTIVE MAINTENANCE .....	PAGE D – 3
<b>PUMP MAINTENANCE AND REPAIR - SECTION E .....</b>	<b>PAGE E – 1</b>
STANDARD PERFORMANCE CURVE .....	PAGE E – 1
PARTS LISTS:	
Pump Model .....	PAGE E – 3
Power Unit Kit .....	PAGE E – 5
Pump End Assy .....	PAGE E – 7
Repair Rotating Assy .....	PAGE E – 9
Drive Assy .....	PAGE E – 10
PUMP AND SEAL DISASSEMBLY AND REASSEMBLY .....	PAGE E – 11
Back Cover And Wear Plate Removal .....	PAGE E – 11
Suction Check Valve Removal .....	PAGE E – 12
Separating Intermediate And Drive Assembly From Engine .....	PAGE E – 12
Loosening Impeller .....	PAGE E – 12
Rotating Assembly Removal .....	PAGE E – 13
Impeller Removal .....	PAGE E – 13
Seal Removal .....	PAGE E – 13
Shaft and Bearing Removal and Disassembly .....	PAGE E – 14
Shaft and Bearing Reassembly and Installation .....	PAGE E – 15
Seal Installation .....	PAGE E – 16
Impeller Installation .....	PAGE E – 19
Rotating Assembly Installation .....	PAGE E – 19
Suction Check Valve Installation .....	PAGE E – 19
Back Cover Installation And Adjustment .....	PAGE E – 19
Securing Pump End To Engine .....	PAGE E – 20
PRESSURE RELIEF VALVE MAINTENANCE .....	PAGE E – 21
Final Pump Assembly .....	PAGE E – 22
LUBRICATION .....	PAGE E – 22
Seal Assembly .....	PAGE E – 22
Bearings .....	PAGE E – 22
Engine .....	PAGE E – 22

## INTRODUCTION

**Thank You** for purchasing a Gorman-Rupp pump. **Read this manual** carefully to learn how to safely install and operate your pump. Failure to do so could result in personal injury or damage to the pump.

This pump is a Super T Series, semi-open impeller, self-priming centrifugal model with a suction check valve. The pump also is designed with external shimless adjusters for setting the wear plate to impeller clearance. The pump is close coupled to a Deutz F4L diesel engine, and is designed for handling dirty water containing specified entrained solids and slurries. The basic material of construction is type CD4MCu stainless steel.

Because pump installations are seldom identical, this manual cannot possibly provide detailed instructions and precautions for every aspect of each specific application. Therefore, it is the responsibility of the owner/installer of the pump to ensure that applications not addressed in this manual are performed **only** after establishing that neither operator safety nor pump integrity are compromised by the installation. Pumps and related equipment **must** be installed and operated according to all national, local and industry standards.

For information or technical assistance on the engine, contact the engine manufacturer's local dealer or representative.

If there are any questions regarding the pump or its application which are not covered in this manual or in other literature accompanying this unit, please contact your Gorman-Rupp distributor, or write:

**The Gorman-Rupp Company**  
**P.O. Box 1217**  
**Mansfield, Ohio 44901—1217**  
**Phone: (419) 755—1011**  
 or:  
**Gorman-Rupp of Canada Limited**  
**70 Burwell Road**  
**St. Thomas, Ontario N5P 3R7**  
**Phone: (519) 631—2870**

The following are used to alert maintenance personnel to procedures which require special attention, to those which could damage equipment, and to those which could be dangerous to personnel:



**Immediate hazards which WILL result in severe personal injury or death. These instructions describe the procedure required and the injury which will result from failure to follow the procedure.**



**Hazards or unsafe practices which COULD result in severe personal injury or death. These instructions describe the procedure required and the injury which could result from failure to follow the procedure.**

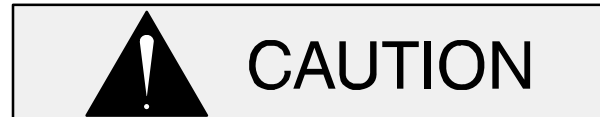

Hazards or unsafe practices which COULD result in minor personal injury or product or property damage. These instructions describe the requirements and the possible damage which could result from failure to follow the procedure.

### NOTE

*Instructions to aid in installation, operation, and maintenance or which clarify a procedure.*

## SAFETY - SECTION A

This information applies to Super T Series engine driven pumps. Refer to the manual accompanying the engine before attempting to begin operation.

Because pump installations are seldom identical, this manual cannot possibly provide detailed instructions and precautions for each specific application. Therefore, it is the owner/installer's responsibility to ensure that applications not addressed in this manual are performed only after establishing that neither operator safety nor pump integrity are compromised by the installation.



Before attempting to open or service the pump:

1. Familiarize yourself with this manual.
2. Set the HAND-OFF-AUTO switch to 'OFF', and disconnect the positive battery cable to ensure that the pump will remain inoperative.
3. Allow the pump to completely cool if overheated.
4. Check the temperature before opening any covers, plates, or plugs.
5. Close the suction and discharge valves.
6. Vent the pump slowly and cautiously.
7. Drain the pump.



This pump is equipped with an automatic starting system, and is subject to automatic restart. Keep hands and clothing away from the unit to prevent injury

during automatic operation. Disconnect the positive battery cable before performing any maintenance. Failure to do so may result in serious personal injury.



This pump is designed to handle mild industrial corrosives, residues or slurries containing specified entrained solids. Do not attempt to pump volatile, corrosive, or flammable materials which may damage the pump or endanger personnel as a result of pump failure.



Use lifting and moving equipment in good repair and with adequate capacity to prevent injuries to personnel or damage to equipment. The bail is intended for use in lifting the pump assembly only. Suction and discharge hoses and piping must be removed from the pump before lifting.



After the unit has been installed, make certain that the pump and all piping or hose connections are tight, properly supported and secure before operation.



Do not operate the pump against a closed discharge valve for long periods of time. If operated against a closed discharge valve, pump components will deteriorate, and the liquid could come

to a boil, build pressure, and cause the pump casing to rupture or explode.



This pump is designed to handle materials which could cause illness or injury through direct exposure or emitted fumes. Wear adequate protective clothing when working on the pump or piping.



Do not remove plates, covers, gauges, pipe plugs, or fittings from an overheated pump. Vapor pressure within the pump can cause parts being disengaged to be ejected with great force. Allow the pump to completely cool before servicing.



Do not operate an internal combustion engine in an explosive atmosphere. When operating internal combustion engines in an enclosed area, make certain that exhaust fumes are piped to the

outside. These fumes contain carbon monoxide, a deadly gas that is colorless, tasteless, and odorless.



Fuel used by internal combustion engines presents an extreme explosion and fire hazard. Make certain that all fuel lines are securely connected and free of leaks. Never refuel a hot or running engine. Avoid overfilling the fuel tank. Always use the correct type of fuel.



Never tamper with the governor to gain more power. The governor establishes safe operating limits that should not be exceeded. The maximum continuous operating speed for this pump is 1700 RPM.



Pumps and related equipment must be installed and operated according to all national, local and industry standards.

## INSTALLATION – SECTION B

### Review all SAFETY information in Section A.

Since pump installations are seldom identical, this section offers only general recommendations and practices required to inspect, position, and arrange the pump and piping.

Most of the information pertains to a standard **static lift** application where the pump is positioned above the free level of liquid to be pumped.

If installed in a **flooded suction application** where the liquid is supplied to the pump under pressure, some of the information such as mounting, line configuration, and priming must be tailored to the

specific application. Since the pressure supplied to the pump is critical to performance and safety, **be sure** to limit the incoming pressure to 50% of the maximum permissible operating pressure as shown on the pump performance curve.

For further assistance, contact your Gorman-Rupp distributor or the Gorman-Rupp Company.

### Pump Dimensions

See Figure 1 for the approximate physical dimensions of this pump.

### OUTLINE DRAWING

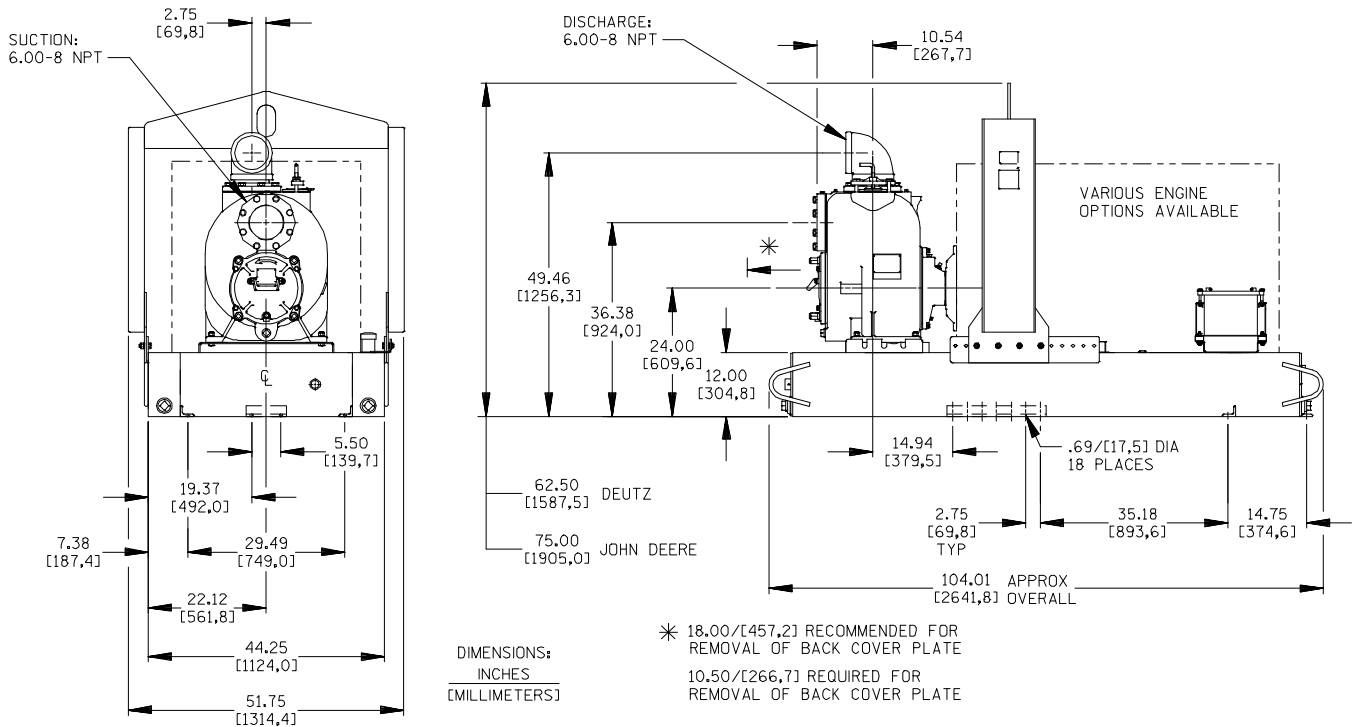

Figure 1. Pump Model T6A65S-F4L



**PREINSTALLATION INSPECTION**

The pump assembly was inspected and tested before shipment from the factory. Before installation, inspect the pump for damage which may have occurred during shipment. Check as follows:

- a. Inspect the pump assembly for cracks, dents, damaged threads, and other obvious damage.
- b. Check for and tighten loose attaching hardware. Since gaskets tend to shrink after drying, check for loose hardware at mating surfaces.
- c. Carefully read all tags, decals, and markings on the pump assembly, and perform all duties indicated.
- d. Check levels and lubricate as necessary. Refer to **LUBRICATION** in the **MAINTENANCE AND REPAIR** section of this manual and perform duties as instructed.
- e. If the pump and engine have been stored for more than 12 months, some of the components or lubricants may have exceeded their maximum shelf life. These **must be inspected or replaced** to ensure maximum pump service.

If the maximum shelf life has been exceeded, or if anything appears to be abnormal, contact your Gorman-Rupp distributor or the factory to determine the repair or updating policy. **Do not** put the pump into service until appropriate action has been taken.

**Battery Specifications And Installation**

Unless otherwise specified on the pump order, the engine battery was **not** included with the unit. Refer to the following specifications when selecting a battery.

**Table 1. Battery Specifications**

Voltage	Cold Crank Amps @ 0° F	Reserve Capacity @ 80° F (Minutes)	Amp/ Hr. Rating	Approx. Overall Dims. (Inches)
12 Volts	850	120	75	10.25L x 6.75W x 8.88H

Refer to the information accompanying the battery and/or electrolyte solution for activation and charging instructions.

Before installing the battery, clean the positive and negative cable connectors, and the battery terminals. Secure the battery by tightening the holddown brackets. The terminals and clamps may be coated with petroleum jelly to retard corrosion. Connect and tighten the positive cable first, then the negative cable.

**POSITIONING PUMP**



**WARNING!**

**Use lifting and moving equipment in good repair and with adequate capacity to prevent injuries to personnel or damage to equipment. The bail is intended for use in lifting the pump assembly only. Suction and discharge hoses and piping must be removed from the pump before lifting.**

**Lifting**

Pump unit weights will vary depending on the mounting and drive provided. Check the shipping tag on the unit packaging for the actual weight, and use lifting equipment with appropriate capacity. Drain the pump and remove all customer-installed equipment such as suction and discharge hoses or piping before attempting to lift existing, installed units.



**CAUTION**

The pump assembly can be seriously

damaged if the cables or chains used to lift and move the unit are improperly wrapped around the pump.

### Mounting

Locate the pump in an accessible place as close as practical to the liquid being pumped. Level mounting is essential for proper operation.

The pump may have to be supported or shimmed to provide for level operation or to eliminate vibration.

If the pump has been mounted on a moveable base, make certain the base is stationary by setting the brake and blocking the wheels before attempting to operate the pump.

To ensure sufficient lubrication and fuel supply to the engine, **do not** position the pump and engine more than 15° off horizontal for continuous operation. The pump and engine may be positioned up to 30° off horizontal for **intermittent operation only**; however, the engine manufacturer should be consulted for continuous operation at angles greater than 15°.

### Clearance

When positioning the pump, allow a minimum clearance of **18 inches (457,2 mm)** in front of the back cover to permit removal of the cover and easy access to the pump interior.

## SUCTION AND DISCHARGE PIPING

Pump performance is adversely effected by increased suction lift, discharge elevation, and friction losses. See the performance curve and notes on Page E-1 to be sure your overall application allows pump to operate within the safe operation range.

### Materials

Either pipe or hose maybe used for suction and discharge lines; however, the materials must be compatible with the liquid being pumped. If hose is used in suction lines, it must be the rigid-wall, reinforced type to prevent collapse under suction. Us-

ing piping couplings in suction lines is not recommended.

### Line Configuration

Keep suction and discharge lines as straight as possible to minimize friction losses. Make minimum use of elbows and fittings, which substantially increase friction loss. If elbows are necessary, use the long-radius type to minimize friction loss.

### Connections to Pump

Before tightening a connecting flange, align it exactly with the pump port. Never pull a pipe line into place by tightening the flange bolts and/or couplings.

Lines near the pump must be independently supported to avoid strain on the pump which could cause excessive vibration, decreased bearing life, and increased shaft and seal wear. If hose-type lines are used, they should have adequate support to secure them when filled with liquid and under pressure.

### Gauges

Most pumps are drilled and tapped for installing discharge pressure and vacuum suction gauges. If these gauges are desired for pumps that are not tapped, drill and tap the suction and discharge lines not less than 18 inches (457,2 mm) from the suction and discharge ports and install the lines. Installation closer to the pump may result in erratic readings.

## SUCTION LINES

To avoid air pockets which could affect pump priming, the suction line must be as short and direct as possible. When operation involves a suction lift, the line must always slope upward to the pump from the source of the liquid being pumped; if the line slopes down to the pump at any point along the suction run, air pockets will be created.

### Fittings

Suction lines should be the same size as the pump inlet. If reducers are used in suction lines, they should be the eccentric type, and should be in-

stalled with the flat part of the reducers uppermost to avoid creating air pockets. Valves are not normally used in suction lines, but if a valve is used, install it with the stem horizontal to avoid air pockets.

### Strainers

If a strainer is furnished with the pump, be certain to use it; any spherical solids which pass through a strainer furnished with the pump will also pass through the pump itself.

If a strainer is not furnished with the pump, but is installed by the pump user, make certain that the total area of the openings in the strainer is at least three or four times the cross section of the suction line, and that the openings will not permit passage of solids larger than the solids handling capability of the pump.

This pump is designed to handle up to 3-inch (76,2 mm) diameter spherical solids.

### Sealing

Since even a slight leak will affect priming, head, and capacity, especially when operating with a high suction lift, all connections in the suction line should be sealed with pipe dope to ensure an airtight seal. Follow the sealant manufacturer's recommendations when selecting and applying the pipe dope. The pipe dope should be compatible with the liquid being pumped.

### Suction Lines In Sumps

If a single suction line is installed in a sump, it should be positioned away from the wall of the

sump at a distance equal to 1 1/2 times the diameter of the suction line.

If there is a liquid flow from an open pipe into the sump, the flow should be kept away from the suction inlet because the inflow will carry air down into the sump, and air entering the suction line will reduce pump efficiency.

If it is necessary to position inflow close to the suction inlet, install a baffle between the inflow and the suction inlet at a distance 1-1/2 times the diameter of the suction pipe. The baffle will allow entrained air to escape from the liquid before it is drawn into the suction inlet.

If two suction lines are installed in a single sump, the flow paths may interact, reducing the efficiency of one or both pumps. To avoid this, position the suction inlets so that they are separated by a distance equal to at least 3 times the diameter of the suction pipe.

### Suction Line Positioning

The depth of submergence of the suction line is critical to efficient pump operation. Figure 2 shows recommended minimum submergence vs. velocity.

#### NOTE

*The pipe submergence required may be reduced by installing a standard pipe increaser fitting at the end of the suction line. The larger opening size will reduce the inlet velocity. Calculate the required submergence using the following formula based on the increased opening size (area or diameter).*

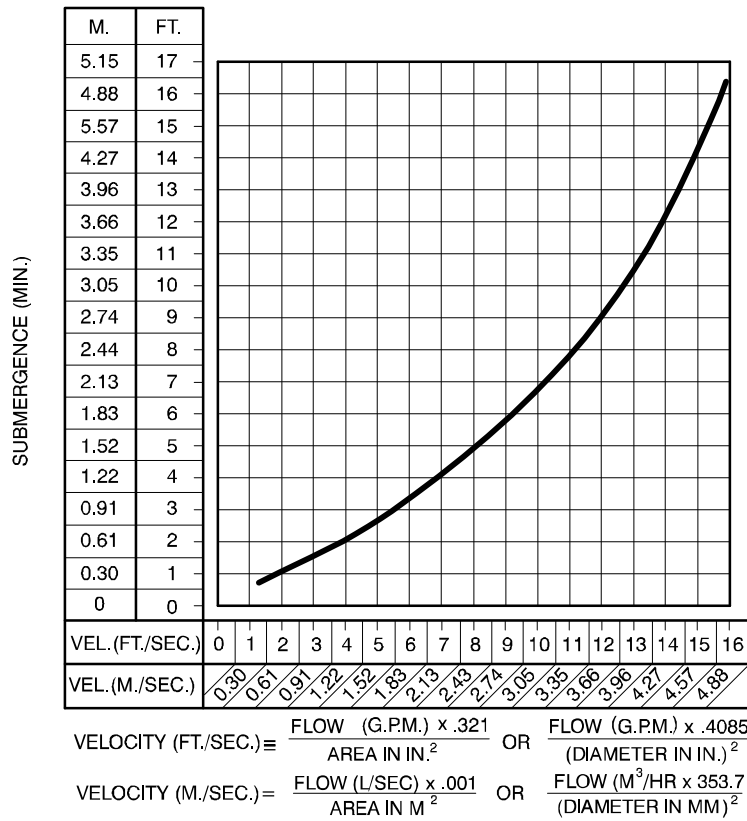

Figure 2. Recommended Minimum Suction Line Submergence vs. Velocity

**FLOAT SWITCHES**

**Installation**

The standard pump is equipped with an auto-start control system, and can be conformed to start and stop as the liquid level in the wet well or sump rises and falls. The autostart unit employs either a single or double float switch system, where a bulb raises or lowers (floats) with the liquid level, thus activating an enclosed miniature switch. The floats are equipped with a socket type connector that plugs into a matching receptacle on the auto-start control box.

Standard floats are equipped with 50 feet (15,2 m) of cable.

When installing the floats, note the following:

- a. **Be sure** to provide sufficient room in the wet well or sump so that floats do not get obstructed or drawn into the suction line. If a flexible suction hose is used, it may be extended to lay along the bottom of the wet well or sump and the float can be attached to the hose

above the point where it bends along the bottom. Direct the suction line toward the flow, and the float(s) away from the flow. If a standpipe is available, attach the float switch cable to the standpipe in the sump at the approximate desired liquid level.

- b. In a single float system, the cable can be tethered to the suction line or standpipe approximately 6 inches (152 mm) above the float. This setting allows approximately 9 inches (229 mm) of liquid rise between pump start/stop. The start/stop interval may be increased by extending the float end of the cable. The liquid level in the sump will increase approximately 8 inches (203 mm) between start/stop intervals for every 6 inches (152 mm) of cable increase.
- c. If a double float switch system is used, position the “Start” float at the desired high water level in the sump, and the “Stop” float at the desired low water level in the pump.
- d. Refer to Figure 3 for additional float switch data.

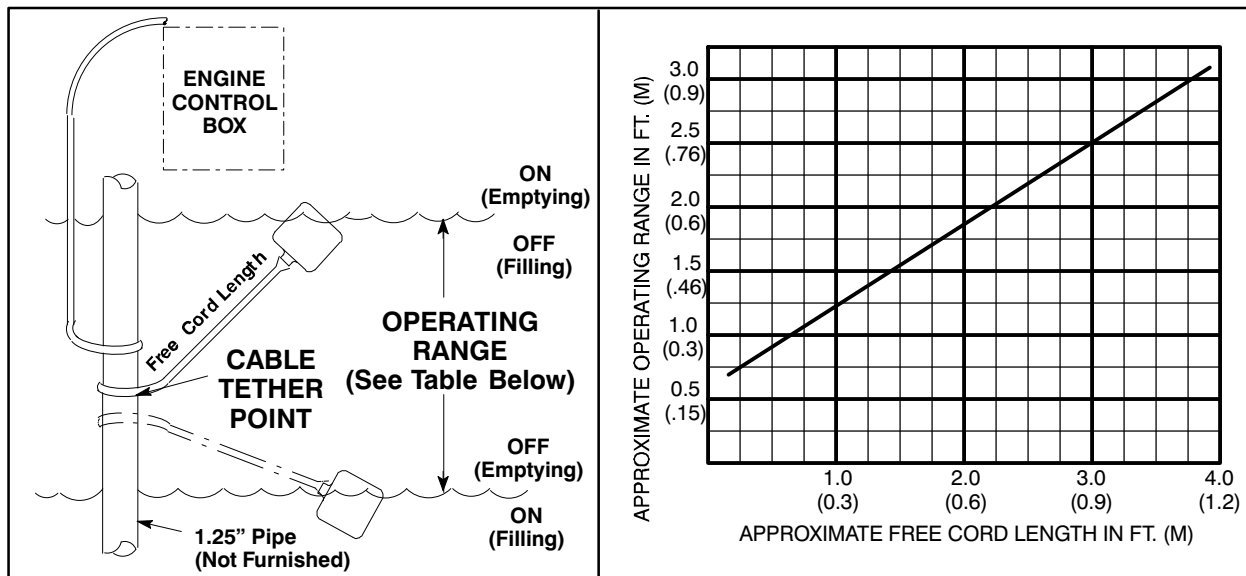

Figure 3. Float Switch Data

**OPTIONAL SUBMERSIBLE TRANSDUCER**

This unit may be equipped with an optional Electronic Pressure Switch (EPS) that works in conjunction with a submersible transducer. The submersible transducer converts pressure to an electrical signal proportional to liquid level. This electrical signal is distributed to the digital display on the EPS through a scaling circuit which converts the electrical signal to “feet of water”.

When installing the submersible transducer, note the following:

- a. Handle the signal cable and transducer with care during installation. **Carefully** lower the transducer into the wet well or sump; **do not** drop it to the bottom. To avoid clogging, suspend the transducer off the bottom.
- b. **Be sure** to provide sufficient room in the wet well or sump so that the transducer does not get drawn into the suction line. To prevent this, a flexible suction hose may be extended to lay along the bottom of the wet well or sump. The transducer can then be attached to the hose

above the point where it bends along the bottom. See Figure B-4 for a typical installation.

- c. The wet well or sump must be vented to atmosphere.
- d. The EPS is scaled in feet of water column. If the measured medium is other than 1.0 specific gravity, the reading on the EPS should be divided by the specific gravity of the measured medium to obtain the actual level.
- e. **Thoroughly** clean the transducer after each use to prevent clogging.



**Do not** disassemble the transducer or loosen the compression nut at the signal cable entry. **This will void warranty.** There are no user-serviceable parts inside. Do not nick or cut the jacket of the signal cable; this will cause leakage and **void warranty.**

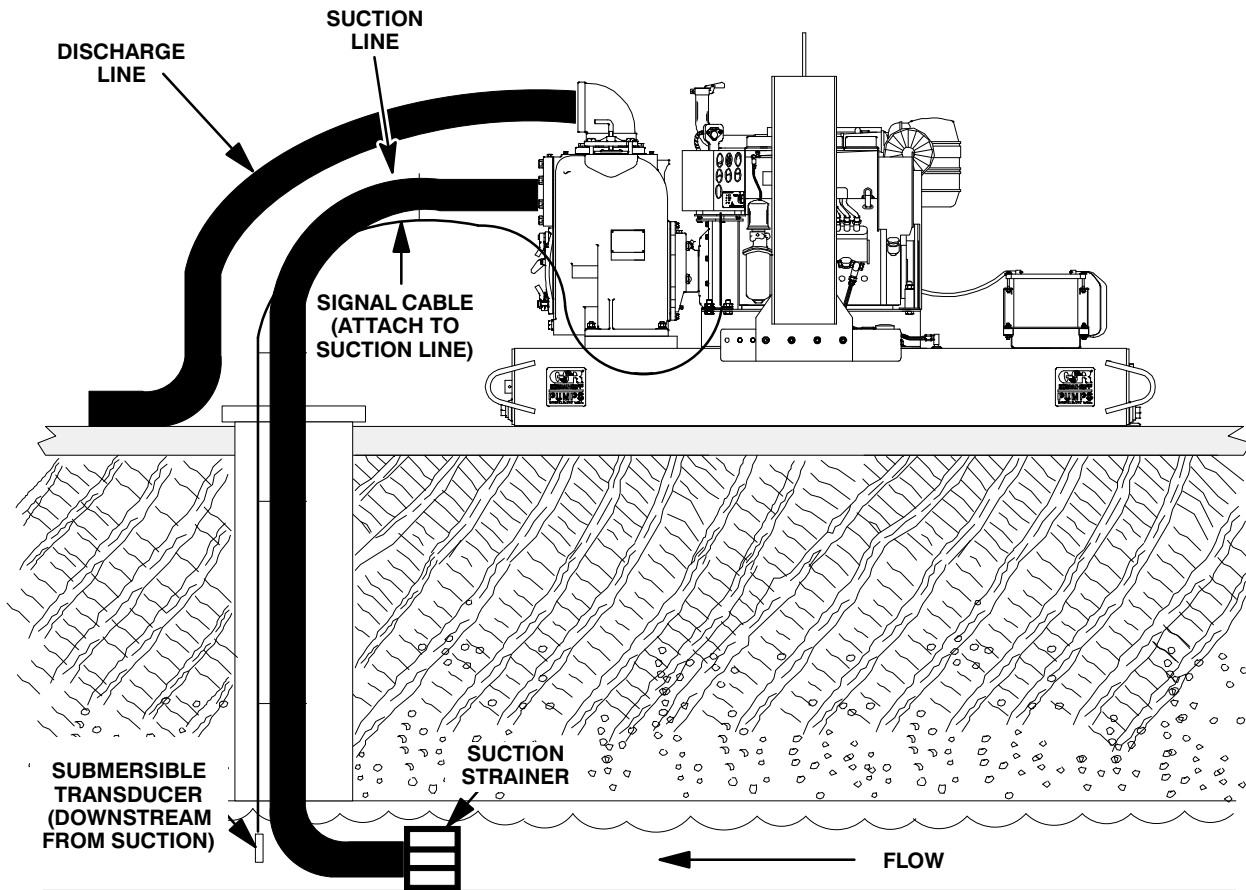

Figure 4. Typical Submersible Transducer Installation

**DISCHARGE LINES**

**Siphoning**

Do not terminate the discharge line at a level lower than that of the liquid being pumped unless a siphon breaker is used in the line. Otherwise, a siphoning action causing damage to the pump could result.

**Valves**

If a throttling valve is desired in the discharge line, use a valve as large as the largest pipe to minimize friction losses. Never install a throttling valve in a suction line.

With high discharge heads, it is recommended that a throttling valve and a system check valve be installed in the discharge line to protect the pump from excessive shock pressure and reverse rotation when it is stopped.

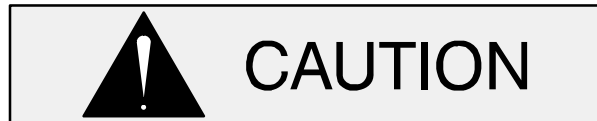

If the application involves a high discharge head, gradually close the discharge throttling valve before stopping the pump.

**Bypass Lines**

Self-priming pumps are not air compressors. During the priming cycle, air from the suction line must be vented to atmosphere on the discharge side. If the discharge line is open, this air will be vented through the discharge. However, if a check valve has been installed in the discharge line, the discharge side of the pump must be opened to atmospheric pressure through a bypass line installed between the pump discharge and the check valve. A self-priming centrifugal pump **will not prime** if there is sufficient static liquid head to hold the discharge check valve closed.

**NOTE**

*The bypass line should be sized so that it does not*

affect pump discharge capacity; however, the bypass line should be at least 1 inch (25,4 mm) in diameter to minimize the chance of plugging.

In **low discharge head applications** (less than 30 feet (9,1 m)), it is recommended that the bypass line be run back to the wet well, and located 6 inches below the water level or cut-off point of the low level pump. In some installations, this bypass outline may be terminated with a six-to-eight foot (1,8 to 2,4 m) length of 1-1/4 inch (31,8 mm) I.D. **smooth-bore** hose; air and liquid vented during the priming process will then agitate the hose and break up any solids, grease, or other substances likely to cause clogging.

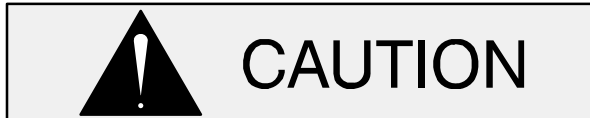

A bypass line that is returned to a wet well must be secured against being drawn into the pump suction inlet.

It is also recommended that pipe unions be installed at each 90° elbow in a bypass line to ease disassembly and maintenance.

In **high discharge head applications** (more than 30 feet (9,1 m)), an excessive amount of liquid may be bypassed and forced back to the wet well under the full working pressure of the pump; this will reduce overall pumping efficiency. **Therefore, it is recommended that a Gorman-Rupp Automatic Air Release Valve be installed in the bypass line.**

Gorman-Rupp Automatic Air Release Valves are reliable, and require minimum maintenance. See **Automatic Air Release Valves** in this section for installation and theory of operation of the Automatic Air Release Valve. Consult your Gorman-Rupp distributor, or contact the Gorman-Rupp Company for selection of an Automatic Air Release Valve to fit your application.



Except in certain specific applications (to prevent flooding during service of an auto-

matic air release valve in a below-ground lift station), if a manual shut-off valve is installed **anywhere** in a bypass line, it **must** be a full-opening, **ball-type** valve to prevent plugging by solids.



**A manual shut-off valve should not be installed in any bypass line. A manual shut-off valve may inadvertently be left closed during operation. A pump which has lost prime may continue to operate without reaching prime, causing dangerous overheating and possible explosive rupture of the pump casing. Personnel could be severely injured.**

**Allow an over-heated pump to completely cool before servicing. Do not remove plates, covers, gauges, or fittings from an over-heated pump. Liquid within the pump can reach boiling temperatures, and vapor pressure within the pump can cause parts being disengaged to be ejected with great force. After the pump completely cools, drain the liquid from the pump by removing the casing drain plug. Use caution when removing the plug to prevent injury to personnel from hot liquid.**

## AUTOMATIC AIR RELEASE VALVE

When properly installed and correctly adjusted to the specific hydraulic operating conditions of the application, the Gorman-Rupp Automatic Air Release Valve will permit air to escape through the bypass line, and then close automatically when the pump is fully primed and pumping at full capacity.

### Theory of Operation

Figures 5 and 6 show a cross-sectional view of the Automatic Air Release Valve, and a corresponding description of operation.

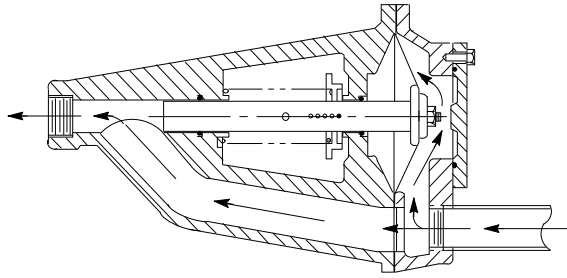

**Figure 5. Valve in Open Position**

During the priming cycle, air from the pump casing flows through the bypass line, and passes through the Air Release Valve to the wet well (Figure 5).

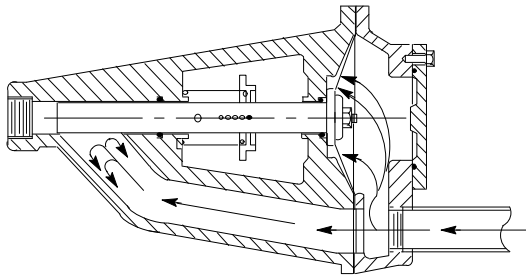

**Figure 6. Valve in Closed Position**

When the pump is fully primed, pressure resulting from flow against the valve diaphragm compresses the spring and closes the valve (Figure 6). The valve will remain closed, reducing the bypass of liquid to 1 to 5 gallons per minute, until the pump loses its prime or stops.



**WARNING!**

**Some leakage (1 to 5 gallons (3,8 to 18,9**

**Liters) per minute) will occur when the valve is fully closed. Be sure the bypass line is directed back to the wet well or tank to prevent hazardous spills.**

When the pump shuts down, the spring returns the diaphragm to its original position. Any solids that may have accumulated in the diaphragm chamber settle to the bottom and are flushed out during the next priming cycle.

**NOTE**

*The valve will remain open if the pump does not reach its designed capacity or head. Valve closing pressure is dependent upon the discharge head of the pump at full capacity. The range of the valve closing pressure is established by the tension rate of the spring as ordered from the factory. Valve closing pressure can be further adjusted to the exact system requirements by moving the spring retaining pin up or down the plunger rod to increase or decrease tension on the spring. Contact your Gorman-Rupp distributor or the Gorman-Rupp Company for information about an Automatic Air Release Valve for your specific application.*

**Air Release Valve Installation**

The Automatic Air Release Valve must be independently mounted in a horizontal position and connected to the discharge line of the self-priming centrifugal pump (see Figure 7).

**NOTE**

*If the Air Release Valve is to be installed on a **staged** pump application, contact the factory for specific installation instructions.*



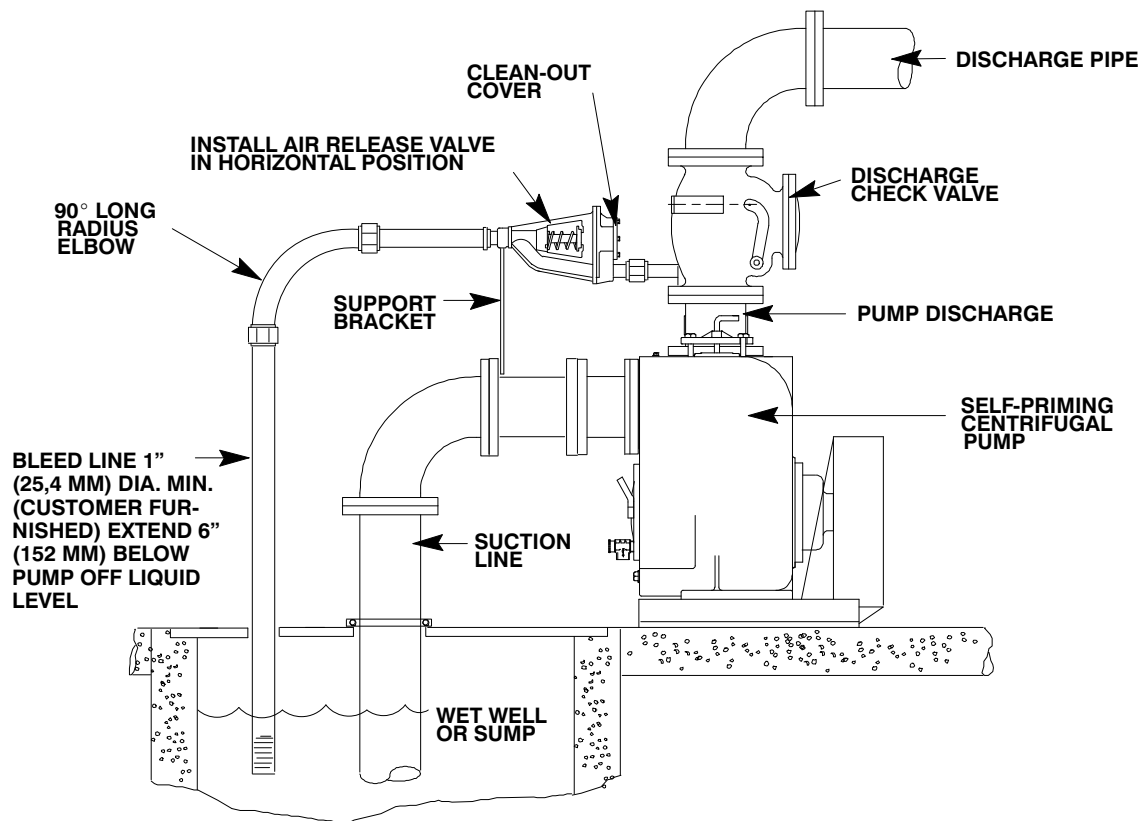

**Figure 7. Typical Automatic Air Release Valve Installation**

The valve inlet line must be installed between the pump discharge port and the non-pressurized side of the discharge check valve. The valve inlet is at the large end of the valve body, and is provided with standard 1 inch NPT pipe threads.

The valve outlet is located at the opposite end of the valve, and is also equipped with standard 1 inch NPT pipe threads. The outlet should be connected to a bleed line which slopes back to the wet well or sump. The bleed line must be the same size as the inlet piping, or larger. If **piping** is used for the bleed line, avoid the use of elbows whenever possible.

#### **NOTE**

*It is recommended that each Air Release Valve be*

*fitted with an independent bleeder line directed back to the wet well. If multiple Air Release Valves are installed in a system, they **must** be fitted with independent bleeder lines; **never** use a common manifold pipe. Contact your Gorman-Rupp distributor or the Gorman-Rupp Company for information about installation of an Automatic Air Release Valve for your specific application.*

#### **ALIGNMENT**

The alignment of the pump and the engine is critical for trouble-free mechanical operation. See Section E, **Securing Intermediate And Drive Assembly To Engine** for detailed information.

## OPERATION – SECTION C

Review all **SAFETY** information in Section A.

Follow the instructions on all tags, labels and decals attached to the pump.



Do not operate an internal combustion engine in an explosive atmosphere. When operating internal combustion engines in an enclosed area, make certain that exhaust fumes are piped to the outside. These fumes contain carbon monoxide, a deadly gas that is colorless, tasteless, and odorless.



This pump is designed to handle mild industrial corrosives, residues or slurries containing specified entrained solids. Do not attempt to pump volatile, corrosive, or flammable materials which may damage the pump or endanger personnel as a result of pump failure.



Never tamper with the governor to gain more power. The governor establishes safe operating limits that should not be exceeded. The maximum continuous operating speed for this pump is 1700 RPM.

### PRIMING

Install the pump and piping as described in **INSTALLATION**. Make sure that the piping connections are tight, and that the pump is securely mounted. Check that the pump is properly lubri-

cated (see **LUBRICATION** in **MAINTENANCE AND REPAIR**).

This pump is self-priming, but the pump should never be operated unless there is liquid in the pump casing.



Never operate this pump unless there is liquid in the pump casing. The pump will not prime when dry. Extended operation of a dry pump will destroy the seal assembly.

Add liquid to the pump casing when:

1. The pump is being put into service for the first time.
2. The pump has not been used for a considerable length of time.
3. The liquid in the pump casing has evaporated.

Once the pump casing has been filled, the pump will prime and reprime as necessary.



After filling the pump casing, reinstall and tighten the fill plug. Do not attempt to operate the pump unless all connecting piping is securely installed. Otherwise, liquid in the pump forced out under pressure could cause injury to personnel.

To fill the pump, remove the pump casing fill cover or fill plug in the top of the casing, and add clean liquid until the casing is filled. Replace the fill cover or fill plug before operating the pump.

### NOTE

*If the suction or discharge piping is open, a hose can be used to fill the casing through the piping.*

## STARTING



**This pump is equipped with an automatic starting system, and is subject to automatic restart. Keep hands and clothing away from the unit to prevent injury during automatic operation. Disconnect the positive battery cable before performing any maintenance. Failure to do so may result in serious personal injury.**

Consult the operations manual furnished with the engine.

### Manual Starting

On initial start-up, set the engine speed at the half-throttle position. Turn the keyswitch on the control box to the "START" position until the engine starts. Release the key and the switch will return to the "RUN" position.

After the engine starts and the unit is fully primed, adjust the engine RPM until the desired flow rate is achieved.



Pump speed and operating condition points must be within the continuous performance range shown on the curve on page E-1.

### Automatic Starting

Install the float(s) or submersible transducer as described in **INSTALLATION, Section B**.

Follow the procedures outlined for manual starting and throttle adjustment, then turn the key to the "AUTO START" position.

#### NOTE

*For security purposes, the key can be removed with the switch in the "AUTO START" position.*

Press and hold the white "AUTO" button on the control panel until the red "AUTO" light illuminates. The auto-start system is now armed.

#### NOTE

*The unit can continue to be started manually with the keyswitch in the "AUTO START" position by pressing the white "MAN" button on the control. The "Single Lightning Bolt" light on the control will illuminate in conjunction with an audible alarm before the unit starts. The unit can then be stopped manually by pressing the "OFF/SET" button.*

In the auto-start mode, the "Single Lightning Bolt" light will illuminate in conjunction with an audible alarm when the liquid level in the sump or wet well rises and activates the float(s). The light will blink and the alarm will sound for approximately 8 seconds before the unit starts.

When the liquid level in the sump or wet well is sufficiently pumped down, the unit will automatically shut down.

#### NOTE

*If the keyswitch is moved to the "OFF" position while in the auto-start mode, the engine will stop. However, the auto-start process will continue as soon as the keyswitch is moved back to the "AUTO START" position. To cancel the auto-start process, press the "OFF/SET" button.*

The control panel is equipped with high oil temperature, low oil pressure, V-belt and start failure (3 attempts) safety shutdowns. If any of these problems occur, the red "Double Lightning Bolt" light will illuminate to indicate a system fault. When the problem is corrected, press the "OFF/SET" button to reset the control.

#### NOTE

*The "OFF/SET" button has dual functionality when in program mode. If necessary, consult the factory for details on programming functions.*

The unit can be started manually with the keyswitch in the "AUTO START" position by pressing the white "MAN" button. The "Single Lightning Bolt" light will illuminate in conjunction with an audible alarm before the unit starts.

Stop the unit manually by pressing the “OFF/SET” button.

## OPERATION

A Gorman-Rupp automatic air release valve may be installed in a bypass line, or the bypass line may be left open.



**A manual shut-off valve should not be installed in any bypass line. A manual shut-off valve may inadvertently be left closed during operation. A pump which has lost prime may continue to operate without reaching prime, causing dangerous overheating and possible explosive rupture of the pump casing. Personnel could be severely injured.**

### Lines With a Bypass

If a Gorman-Rupp Automatic Air Release Valve has been installed, the valve will automatically open to allow the pump to prime, and automatically close after priming is complete (see **INSTALLATION** for Air Release Valve operation).

If the bypass line is open, air from the suction line will be discharged through the bypass line back to the wet well during the priming cycle. Liquid will then continue to circulate through the bypass line while the pump is in operation.

### Lines Without a Bypass

Open all valves in the discharge line and start the engine. Priming is indicated by a positive reading on the discharge pressure gauge or by a quieter operation. The pump may not prime immediately because the suction line must first fill with liquid. If the pump fails to prime within five minutes, stop it and check the suction line for leaks.

After the pump has been primed, partially close the discharge line throttling valve in order to fill the line slowly and guard against excessive shock pressure which could damage pipe ends, gaskets, sprinkler heads, and any other fixtures connected

to the line. When the discharge line is completely filled, adjust the throttling valve to the required flow rate.

### Leakage

No leakage should be visible at pump mating surfaces, or at pump connections or fittings. Keep all line connections and fittings tight to maintain maximum pump efficiency.

### Liquid Temperature And Overheating

The **maximum** liquid temperature for this pump is 160°F (71°C). Do not apply it at a higher operating temperature.

Overheating can occur if operated with the valves in the suction or discharge lines closed. Operating against closed valves could bring the liquid to a boil, build pressure, and cause the pump to rupture or explode. If overheating occurs, stop the pump and allow it to completely cool before servicing it. Refill the pump casing with cool liquid.



**Allow an over-heated pump to completely cool before servicing. Do not remove plates, covers, gauges, or fittings from an over-heated pump. Liquid within the pump can reach boiling temperatures, and vapor pressure within the pump can cause parts being disengaged to be ejected with great force. After the pump completely cools, drain the liquid from the pump by removing the casing drain plug. Use caution when removing the plug to prevent injury to personnel from hot liquid.**

As a safeguard against rupture or explosion due to heat, this pump is equipped with a pressure relief valve which will open if vapor pressure within the pump casing reaches a critical point. If over-heating does occur, stop the pump immediately and allow it to cool before servicing it. **Approach any over-heated pump cautiously.** It is recommended that the pressure relief valve assembly be replaced at each overhaul, or any time the pump

casing over-heats and activates the valve. **Never** replace this valve with a substitute which has not been specified or provided by the Gorman-Rupp Company.

### Strainer Check

If a suction strainer has been shipped with the pump or installed by the user, check the strainer regularly, and clean it as necessary. The strainer should also be checked if pump flow rate begins to drop. If a vacuum suction gauge has been installed, monitor and record the readings regularly to detect strainer blockage.

**Never** introduce air or steam pressure into the pump casing or piping to remove a blockage. This could result in personal injury or damage to the equipment. If backflushing is absolutely necessary, **liquid pressure** must be limited to 50% of the maximum permissible operating pressure shown on the pump performance curve.

### Pump Vacuum Check

With the pump inoperative, install a vacuum gauge in the system, using pipe dope on the threads. Block the suction line and start the pump. At operating speed the pump should pull a vacuum of 20 inches (508 mm) or more of mercury. If it does not, check for air leaks in the seal, gasket, or discharge valve.

Open the suction line, and read the vacuum gauge with the pump primed and at operation speed. Shut off the pump. The vacuum gauge reading will immediately drop proportionate to static suction lift, and should then stabilize. If the vacuum reading falls off rapidly after stabilization, an air leak exists. Before checking for the source of the leak, check the point of installation of the vacuum gauge.

## STOPPING

### Manual Stopping

In the manual mode, reduce the throttle speed slowly, and allow the engine to idle briefly before switching the HAND-OFF-AUTO switch to 'OFF'.



If the application involves a high discharge head, gradually close the discharge throttling valve before stopping the pump.

After stopping the pump, close and lock the control panel cover, or disconnect the positive battery cable to ensure that the pump will remain inoperative.

### Automatic Stopping

In the automatic mode, the pump will stop when the liquid in the wet well or sump lowers and activates the "Off" float switch(s) or "Off" setpoint stored in the optional EPS. The pump will restart automatically when the liquid rises and activates the "On" float switch(s) or "On" setpoint stored in the optional EPS.

### Safety Shutdown System

The unit is equipped with a safety system to automatically shut down the engine under certain conditions. The engine will automatically shut down:

1. If the engine exceeds its safe operating temperature.
2. If the engine oil pressure drops below design limits.
3. If the engine fails to start within a pre-set period of time.
4. If the engine speed exceeds the safe operating range.
5. If the engine V-belt breaks.

Lights on the control panel will indicate which of the safety features has caused the engine to shut down.

Should any of the safety features cause the engine to shut down, **the cause must be determined and corrected** before putting the unit back into service. The engine **will not restart** until the keyswitch has been returned to the 'OFF' position for at least 10 seconds.

All safety shutdown features are pre-set at the factory for optimum performance and safety; **do not** attempt to adjust these settings.



**Never disconnect any of the safety shutdown features; this will void the warranty and could result in serious damage to the unit and/or injury to personnel. Safety shutdown features are pre-set at the factory; do not attempt to adjust any of the settings. Determine the cause of shutdown before putting the unit back into service. Consult the factory for additional information.**

### OPERATION IN EXTREME HEAT

The safety shutdown system will automatically stop the unit if engine operating temperature exceeds design limits. If engine over-temperature shutdown occurs, allow the unit to cool before re-starting.

If engine overheating continues, check the engine lubricant level and viscosity. Consult the engine operation manual for the recommended lubricant for operation in extreme heat.

If the unit is equipped with the optional auto-start control, the float(s) may need to be adjusted to allow shorter run and longer cooling periods, if possible.



**This pump is equipped with an automatic starting system, and is subject to automatic restart. Keep hands and clothing away from the unit to prevent injury during automatic operation. Disconnect the positive battery cable before performing any maintenance. Failure to do so may result in serious personal injury.**

### Cold Weather Preservation

In below freezing conditions, drain the pump to prevent damage from freezing. Also, clean out any solids by flushing with a hose. Operate the pump for approximately one minute; this will remove any remaining liquid that could freeze the pump rotating parts. If the pump will be idle for more than a few hours, or if it has been pumping liquids containing a large amount of solids, drain the pump, and flush it thoroughly with clean water. To prevent large solids from clogging the drain port and preventing the pump from completely draining, insert a rod or stiff wire in the drain port, and agitate the liquid during the draining process. Clean out any remaining solids by flushing with a hose.

### BEARING TEMPERATURE CHECK

Bearings normally run at higher than ambient temperatures because of heat generated by friction. Temperatures up to 160°F (71°C) are considered normal for bearings, and they can operate safely to at least 180°F (82°C).

Checking bearing temperatures by hand is inaccurate. Bearing temperatures can be measured accurately by placing a contact-type thermometer against the housing. Record this temperature for future reference.

A sudden increase in bearing temperatures is a warning that the bearings are at the point of failing to operate properly. Make certain that the bearing lubricant is of the proper viscosity and at the correct level (see **LUBRICATION** in Section E). Bearing overheating can also be caused by shaft misalignment and/or excessive vibration.

When pumps are first started, the bearings may seem to run at temperatures above normal. Continued operation should bring the temperatures down to normal levels.

## TROUBLESHOOTING – SECTION D

Review all SAFETY information in Section A.



Before attempting to open or service the pump:

1. Familiarize yourself with this manual.
2. Set the HAND-OFF-AUTO switch to 'OFF', and disconnect the positive battery cable to ensure that the pump will remain inoperative.
3. Allow the pump to completely cool if overheated.
4. Check the temperature before opening any covers, plates, or plugs.

5. Close the suction and discharge valves.
6. Vent the pump slowly and cautiously.
7. Drain the pump.



This pump is equipped with an automatic starting system, and is subject to automatic restart. Keep hands and clothing away from the unit to prevent injury during automatic operation. Disconnect the positive battery cable before performing any maintenance. Failure to do so may result in serious personal injury.

TROUBLE	POSSIBLE CAUSE	PROBABLE REMEDY
PUMP FAILS TO PRIME	Not enough liquid in casing.  Suction check valve contaminated or damaged.  Air leak in suction line.  Lining of suction hose collapsed.  Leaking or worn seal or pump gasket.  Suction lift or discharge head too high.  Strainer clogged.	Add liquid to casing. See <b>PRIMING</b> .  Clean or replace check valve.  Correct leak.  Replace suction hose.  Check pump vacuum. Replace leaking or worn seal or gasket.  Check piping installation and install bypass line if needed. See <b>INSTALLATION</b> .  Check strainer and clean if necessary.
PUMP STOPS OR FAILS TO DELIVER RATED FLOW OR PRESSURE	Air leak in suction line.  Lining of suction hose collapsed.  Leaking or worn seal or pump gasket.  Strainer clogged.  Suction intake not submerged at proper level or sump too small.	Correct leak.  Replace suction hose.  Check pump vacuum. Replace leaking or worn seal or gasket.  Check strainer and clean if necessary.  Check installation and correct submergence as needed.

TROUBLE	POSSIBLE CAUSE	PROBABLE REMEDY
PUMP STOPS OR FAILS TO DELIVER RATED FLOW OR PRESSURE (cont.)	<p>Impeller or other wearing parts worn or damaged.</p> <p>Impeller clogged.</p> <p>Discharge head too high.</p> <p>Suction lift too high.</p> <p>Pump speed too slow.</p> <p>EPS limit switches set improperly or submersible transducer clogged.</p>	<p>Replace worn or damaged parts. Check that impeller is properly centered and rotates freely.</p> <p>Free impeller of debris.</p> <p>Install bypass line.</p> <p>Measure lift w/vacuum gauge. Reduce lift and/or friction losses in suction line.</p> <p>Check engine output; consult engine operation manual.</p> <p>Check EPS limit settings; check and clean submersible transducer.</p>
PUMP REQUIRES TOO MUCH POWER	<p>Pump speed too high.</p> <p>Discharge head too low.</p> <p>Liquid solution too thick.</p> <p>Bearing(s) frozen.</p>	<p>Check engine output.</p> <p>Adjust discharge valve.</p> <p>Dilute if possible.</p> <p>Disassemble pump and check bearing(s).</p>
PUMP CLOGS FREQUENTLY	<p>Discharge flow too slow.</p> <p>Suction check valve or foot valve clogged or binding.</p> <p>Liquid solution too thick.</p>	<p>Open discharge valve fully to increase flow rate, and run engine at maximum governed speed.</p> <p>Clean valve.</p> <p>Dilute if possible.</p>
EXCESSIVE NOISE	<p>Cavitation in pump.</p> <p>Pumping entrained air.</p> <p>Pump or drive not securely mounted.</p> <p>Impeller clogged or damaged.</p>	<p>Reduce suction lift and/or friction losses in suction line. Record vacuum and pressure gauge readings and consult local representative or factory.</p> <p>Locate and eliminate source of air bubble.</p> <p>Secure mounting hardware.</p> <p>Clean out debris; replace damaged parts.</p>
BEARINGS RUN TOO HOT	<p>Bearing temperature is high, but within limits.</p> <p>Low or incorrect lubricant.</p> <p>Suction and discharge lines not properly supported.</p> <p>Drive misaligned.</p>	<p>Check bearing temperature regularly to monitor any increase.</p> <p>Check for proper type and level of lubricant.</p> <p>Check piping installation for proper support.</p> <p>Align drive properly.</p>



### PREVENTIVE MAINTENANCE

Since pump applications are seldom identical, and pump wear is directly affected by such things as the abrasive qualities, pressure and temperature of the liquid being pumped, this section is intended only to provide general recommendations and practices for preventive maintenance. Regardless of the application however, following a routine preventive maintenance schedule will help assure trouble-free performance and long life from your Gorman-Rupp pump. For specific questions concerning your application, contact your Gorman-Rupp distributor or the Gorman-Rupp Company.

Record keeping is an essential component of a good preventive maintenance program. Changes in suction and discharge gauge readings (if so

equipped) between regularly scheduled inspections can indicate problems that can be corrected before system damage or catastrophic failure occurs. The appearance of wearing parts should also be documented at each inspection for comparison as well. Also, if records indicate that a certain part (such as the seal) fails at approximately the same duty cycle, the part can be checked and replaced before failure occurs, reducing unscheduled down time.

For new applications, a first inspection of wearing parts at 250 hours will give insight into the wear rate for your particular application. Subsequent inspections should be performed at the intervals shown on the chart below. Critical applications should be inspected more frequently.

<b>Preventive Maintenance Schedule</b>					
<b>Item</b>	<b>Service Interval*</b>				
	<b>Daily</b>	<b>Weekly</b>	<b>Monthly</b>	<b>Semi-Annually</b>	<b>Annually</b>
General Condition (Temperature, Unusual Noises or Vibrations, Cracks, Leaks, Loose Hardware, Etc.)	I				
Pump Performance (Gauges, Speed, Flow)	I				
Bearing Lubrication		I			R
Seal Lubrication (And Packing Adjustment, If So Equipped)		I			R
V-Belts (If So Equipped)			I		
Air Release Valve Plunger Rod (If So Equipped)			I	C	
Front Impeller Clearance (Wear Plate)				I	
Rear Impeller Clearance (Seal Plate)				I	
Check Valve					I
Pressure Relief Valve (If So Equipped)					C
Pump and Driver Alignment					I
Shaft Deflection					I
Bearings					I
Bearing Housing					I
Piping					I
Driver Lubrication – See Mfgr’s Literature					I

**Legend:**  
 I = Inspect, Clean, Adjust, Repair or Replace as Necessary  
 C = Clean  
 R = Replace

\* Service interval based on an intermittent duty cycle equal to approximately 4000 hours annually. Adjust schedule as required for lower or higher duty cycles or extreme operating conditions.

## PUMP MAINTENANCE AND REPAIR - SECTION E

MAINTENANCE AND REPAIR OF THE WEARING PARTS OF THE PUMP WILL MAINTAIN PEAK OPERATING PERFORMANCE.

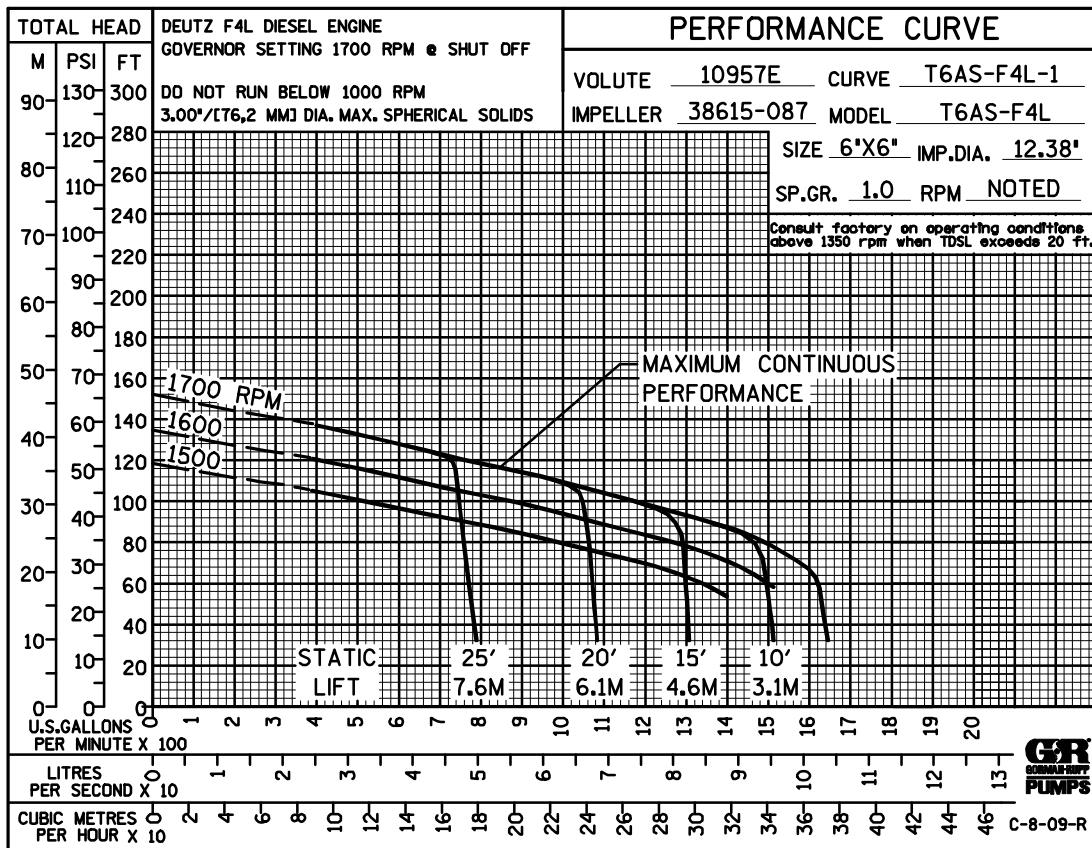

**\* STANDARD PERFORMANCE FOR PUMP MODEL T6A65S-F4L**

\* Based on 70°F (21°C) clear water at sea level with minimum suction lift. Since pump installations are seldom identical, your performance may be different due to such factors as viscosity, specific gravity, elevation, temperature, and impeller trim.

If your pump serial number is followed by an "N", your pump is **NOT** a standard production model.

Contact the Gorman-Rupp Company to verify performance or part numbers.



Pump speed and operating condition points must be within the continuous performance range shown on the curve.

SECTION DRAWING

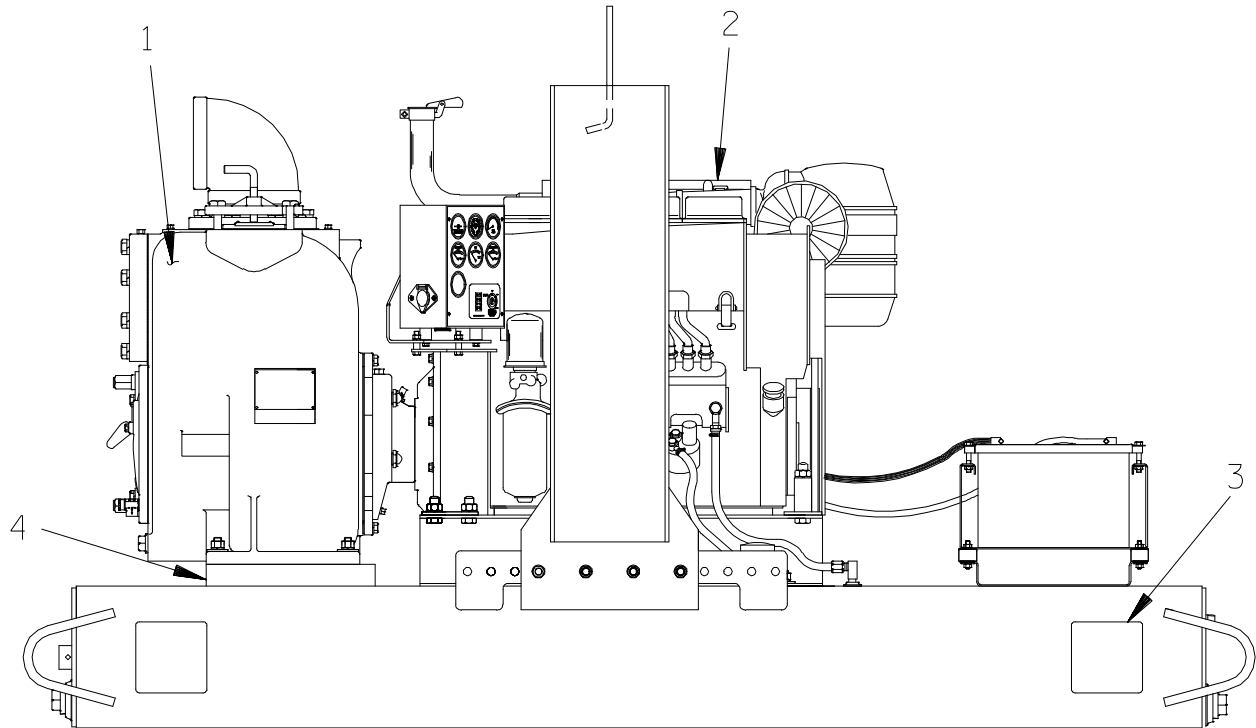

Figure 1. Pump Model T6A65S-F4L

PARTS LIST

(From S/N 1408479 Up)

If your pump serial number is followed by an "N", your pump is **NOT** a standard production model. Contact the Gorman-Rupp Company to verify part numbers.

ITEM NO.	PART NAME	PART NUMBER	MAT'L CODE	QTY
1	PUMP END ASSY	T6A65S-(SAE 4/10)	---	1
2	POWER UNIT KIT	46143-035	---	1
3	G-R DECAL	GR-06	---	4
4	PUMP MOUNTING KIT	48157-003	---	1
NOT SHOWN:				
	WARNING DECAL	2613FE	---	1
OPTIONAL:				
	12V BATTERY	29331-515	---	1
	WHEEL KIT	GRP30-262	---	1

SECTION DRAWING

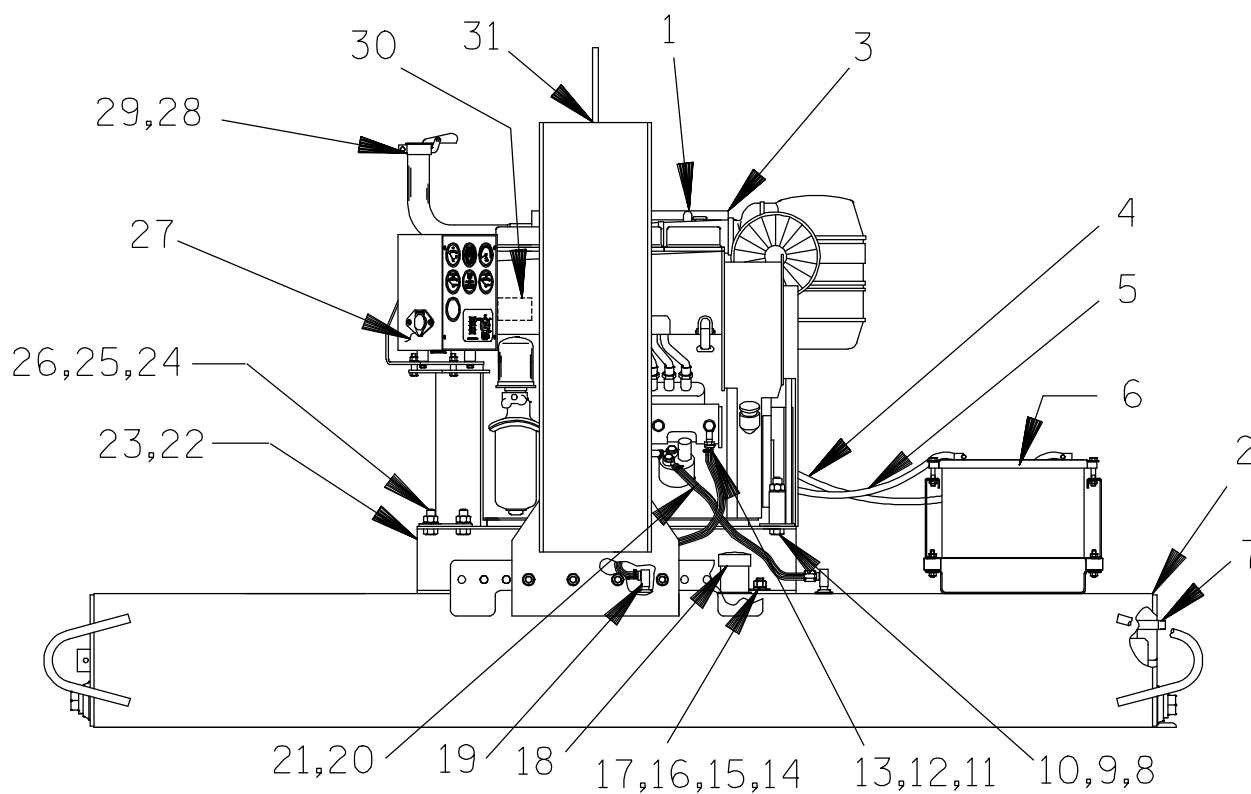

Figure 2. 46143-035 Deutz F4L Power Unit Kit

**PARTS LIST**  
**46143-035 Deutz F4L Power Unit Kit**

ITEM NO.	PART NAME	PART NUMBER	MAT'L CODE	QTY
1	DEUTZ F4L ENGINE	29217-421	---	1
2	BASE/FUEL TANK	41553-006	24150	1
3	MUFFLER GUARD ASSY	42331-031	---	1
4	NEG BATTERY CABLE	47311-134	---	1
5	POS BATTERY CABLE	47311-113	---	1
6	BATTERY BOX ASSY	42432-005	---	1
7	OIL DRAIN ASSY	46342-036	---	1
8	HEX HD CAPSCREW	B1017	15991	2
9	LOCKWASHER	J10	15991	2
10	HEX NUT	D10	15991	2
11	4' HOSE	18513-302	---	1
12	HOSE CLAMP	26518-642	---	2
13	HOSE BARB FITTING	26523-333	---	2
14	HEX HD CAPSCREW	B1007	15991	4
15	HEX NUT	D10	15991	4
16	LOCKWASHER	J10	15991	4
17	FLAT WASHER	K10	15991	8
18	FUEL GAUGE	29332-135	---	1
19	FUEL PICKUP	29332-145	---	2
20	HOSE ASSY	46341-796	---	1
21	MALE CONNECTOR	S1447	---	1
22	R.H. ENGINE SIDE RAIL	34451-085	15080	1
23	L.H. ENGINE SIDE RAIL	34451-086	15080	1
24	HEX HD CAPSCREW	B1007	15991	4
25	HEX NUT	D10	15991	4
26	LOCKWASHER	J10	15991	4
27	CONTROL PANEL KIT	48313-794	---	1
28	EXHAUST ELBOW	31912-023	15990	1
29	WEATHER CAP	S1331	---	1
30	WARNING DECAL	38816-169	---	1
31	LIFTING BAIL KIT	48274-801	---	1
NOT SHOWN:				
	FLOAT SWITCH	48312-980	---	1
	ENGINE STARTUP TAG	38816-269	---	1
	INSTRUCTION DECAL	38818-144	---	1
	WARNING DECAL	38816-203	---	4
	LOW SULFUR FUEL DECAL	38816-196	---	1

SECTION DRAWING

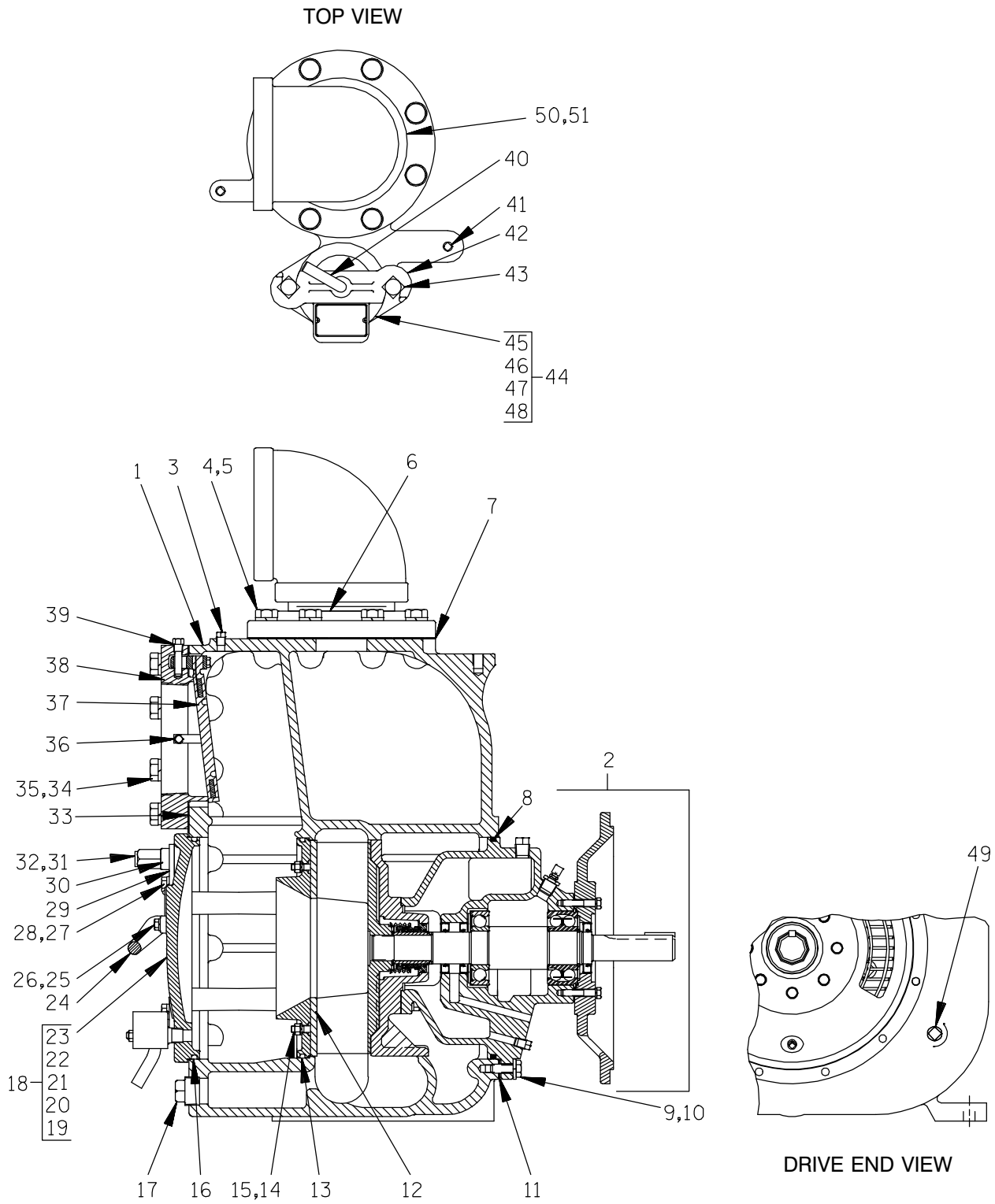

Figure 3. T6A65S-(SAE 4/10) Pump End Assembly

**PARTS LIST**  
**T6A65S--(SAE 4/10) Pump End Assembly**

ITEM NO.	PART NAME	PART NUMBER	MAT'L CODE	QTY	ITEM NO.	PART NAME	PART NUMBER	MAT'L CODE	QTY
1	PUMP CASING	10957E	17180	1	35	LOCK WASHER	J12	17090	8
2	REPAIR ROTATING ASSY	44163-485	----	1	36	PIPE PLUG	P04	17090	1
3	PIPE PLUG	P04	17090	1	37 *	FLAP VALVE ASSY	46411-094	----	1
4	HEX HD CAPSCREW	B1208	17090	8	38	SUCTIO FLANGE	11402	17180	1
5	LOCK WASHER	J12	17090	8	39	CHECK VALVE PIN	11645	17090	1
6	DISCHARGE FLANGE	1758	17070	1	40	CLAMP BAR SCREW	31912-009	1704G	1
7 *	DISCH FLG GASKET	1679G	19410	1	41	PIPE PLUG	P04	17090	1
8 *	BEARING HSG O-RING	25154-454	----	1	42	CLAMP BAR	38111-004	17040	1
9	HEX HD CAPSCREW	B0806	17090	4	43	MACHINE BOLT	A1014	17090	2
10	LOCK WASHER	J08	17090	4	44	FILL CVR PLATE ASSY	42111-385	----	1
11	ROT ASSY ADJ SHIM	13131-3	17040	8	45	-COVER PLATE	NOT AVAILABLE		1
12 *	WEAR PLATE ASSY	46451-723	1718H	1	46	-WARNING PLATE	38816-097	17090	1
13 *	O-RING	25152-453	----	1	47	-DRIVE SCREW	BM#04-03	17090	2
14	HEX NUT	D06	17090	4	48	-COVER GASKET	50G	19210	1
15	LOCK WASHER	J06	17090	4	49	PIPE PLUG	P08	17090	1
16 *	O-RING	25154-454	----	1	50	PIPE NIPPLE	T96	17040	1
17	CASING DRAIN PLUG	P20	17090	1	51	PIPE ELBOW	R96	17040	1
18	BACK CVR PLATE ASSY	42111-816	----	1	NOT SHOWN:				
19 *	-PRESS RELIEF VALVE	46431-803	----	1		DRIVE SCREW	BM#04-03	17000	4
20	-WARNING DECAL	38816-302	----	1		LUBE DECAL	38817-084	----	1
21	-COVER PLATE	NOT AVAILABLE		1		INSTRUCTION LABEL	2613DK	----	1
22	-WARNING PLATE	2613EV	17190	1		ROTATION DECAL	2613M	----	1
23	-DRIVE SCREW	BM#04-03	17090	4		WARNING DECAL	2613FE	----	1
24	COVER PLATE HANDLE	12354	17040	1		NAME PLATE	38818-040	17040	1
25	HEX HD CAPSCREW	B0604	17090	2		SUCTION STICKER	6588AG	----	1
26	LOCK WASHER	J06	17090	2		PRIMING STICKER	6588AH	----	1
27	HEX HD CAPSCREW	B0804-1/2	17090	4		DISCHARGE STICKER	6588BJ	----	1
28	LOCK WASHER	J08	17090	4		SUPER "T" DECAL	38812-089	----	1
29	LOCK COLLAR	38115-551	17040	4		G-R DECAL	GR-03	----	1
30	ADJUSTING SCREW	31871-070	1704G	4		INSTRUCTION TAG	38817-023	----	1
31	STUD	C1213	1706G	4		INSTRUCTIO TAG	38817-011	----	1
32	BACK COVER NUT	31871-073	17040	4		DRIVE ASSEMBLY	44162-119	----	1
33 *	SUCTION FLG GASKET	11402G	19410	1		STRAINER ASSY	7823A	17040	1
34	HEX HD CAPSCREW	B1211	17090	8	OPTIONAL:				
						DISASSEMBLY TOOL	48711-020	----	1

\* INDICATES PARTS RECOMMENDED FOR STOCK

SECTION DRAWING

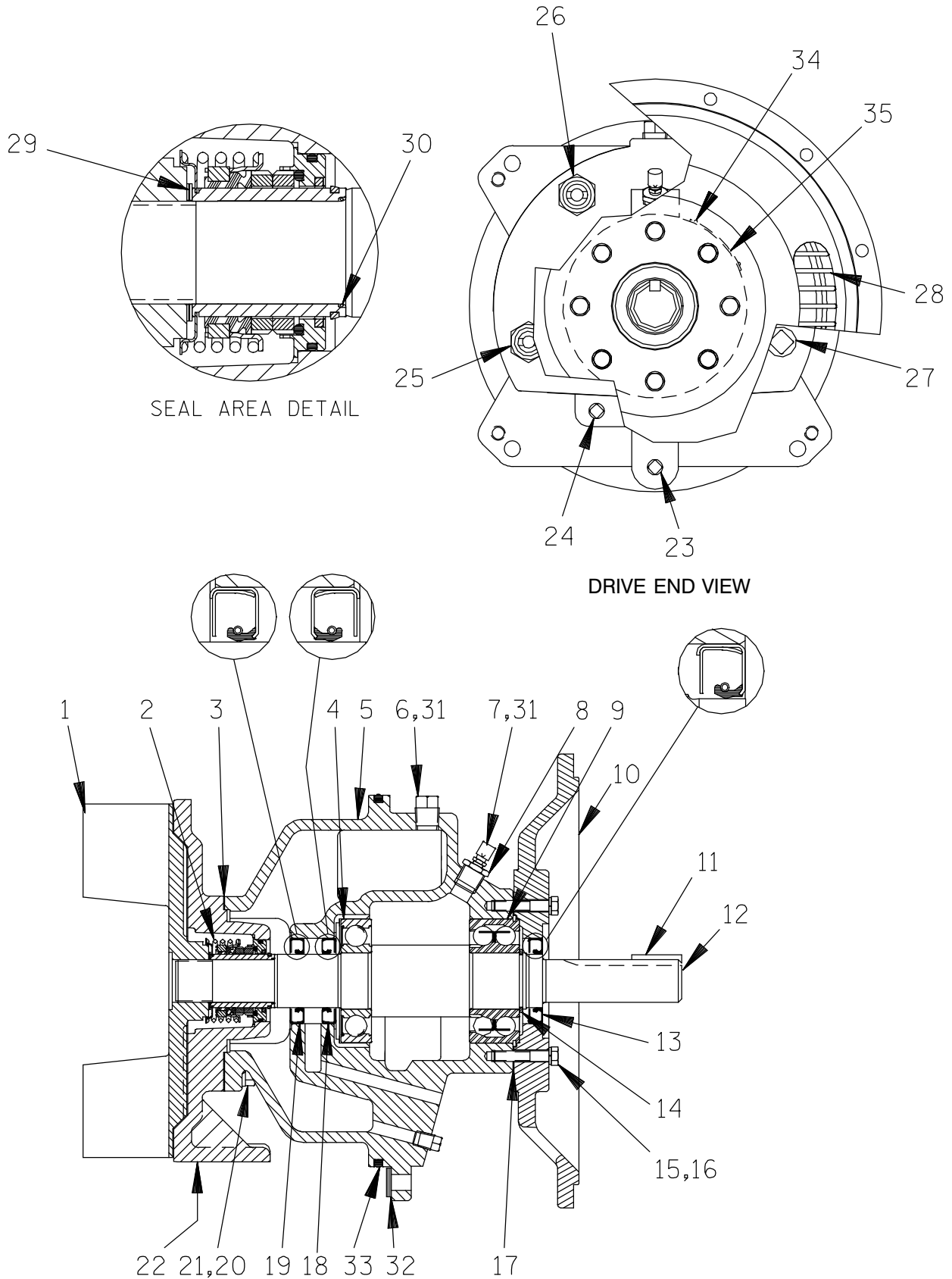

Figure 4. 44163-485 Repair Rotating Assembly



**PARTS LIST**  
**44163-485 Repair Rotating Assembly**

ITEM NO.		PART NAME	PART NUMBER	MAT'L CODE	QTY
1	*	IMPELLER	38615-087	1718H	1
2	*	CARTRIDGE SEAL ASSY	46513-159	---	1
3	*	SEAL PLATE GASKET	10959G	19410	1
4	*	BALL BEARING	S616	---	1
5		BEARING HOUSING	38251-526	17180	1
6		VENTED PLUG	4823A	17040	1
7		AIR VENT	26717-006	---	1
8		REDUCING PIPE BUSHING	AP0802	17040	1
9	*	BALL BEARING	S1030	---	1
10		DRIVE FLANGE	38545-006	10000	1
11	*	SHAFT KEY	N0608	17040	1
12	*	IMPELLER SHAFT	38514-823	1706H	1
13	*	OIL SEAL	S1917	---	1
14		SNAP RING	24124-425	---	1
15		HEX HD CAPSCREW	21632-938	---	8
16		LOCK WASHER	J06	17090	8
17	*	DRIVE FLANGE GASKET	38683-478	19410	1
18	*	OIL SEAL	S1917	---	1
19	*	OIL SEAL	S1917	---	1
20		HEX HD CAPSCREW	B0805-1/2	17090	4
21		LOCK WASHER	J08	17090	4
22		SEAL PLATE	38272-254	1718H	1
23		SEAL CAVITY DRAIN PLUG	P04	17090	1
24		BEARING CAVITY DRAIN PLUG	P04	17090	1
25		BEARING CAVITY SIGHT GAUGE	26714-021	---	1
26		SEAL CAVITY SIGHT GAUGE	26714-021	---	1
27		PIPE PLUG	P12	17090	1
28		GUARD ASSY	42381-509	24152	2
29		IMPELLER ADJ SHIM SET	5091	17090	REF
30		SHAFT SLEEVE O-RING	25154-026	---	REF
31		SHIPPING PLUG	11495B	15079	2
32		ROTATING ASSY ADJ SHIM	13131-3	17040	8
33	*	BEARING HOUSING O-RING	25154-454	---	1
34		DRIVE SCREW	BM#04-03	17090	2
35		S/N PLATE	2613GG	17020	1
NOT SHOWN:					
		ROTATION DECAL	2613M	---	1
		INSTRUCTION TAG	6588U	---	1

\* INDICATES PARTS RECOMMENDED FOR STOCK

SECTION DRAWING

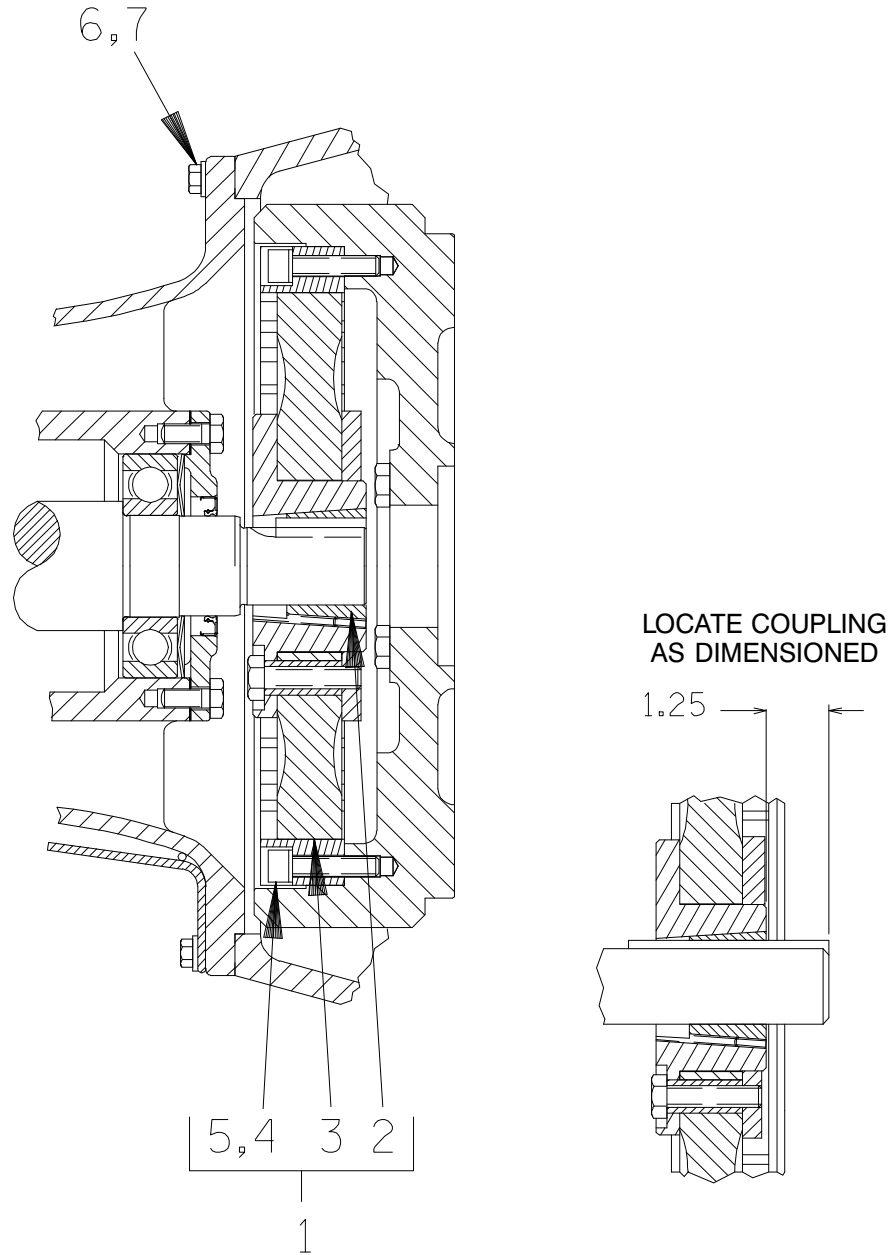

Figure E-5. 44162-119 Drive Assembly  
PARTS LIST

ITEM NO.	PART NAME	PART NUMBER	MAT'L CODE	QTY
1	COUPLING KIT	48112-001	---	1
2	-BUSHING	24131-345	---	1
3	-COUPLING ASSEMBLY	44165-011	---	1
4	-LOCKWASHER	21171-536	---	8
5	-SOCKET HD CAPSCREW	22644-220	---	8
6	HEX HD CAPSCREW	22645-164	---	12
7	LOCKWASHER	21171-511	---	12

## PUMP AND SEAL DISASSEMBLY AND REASSEMBLY

Review all SAFETY information in Section A.

Follow the instructions on all tags, label and decals attached to the pump.

This pump requires little service due to its rugged, minimum-maintenance design. However, if it becomes necessary to inspect or replace the wearing parts, follow these instructions which are keyed to the sectional views (see Figures 1, 2, 3, 4 and 5) and the accompanying parts lists.

This manual will alert personnel to known procedures which require special attention, to those which could damage equipment, and to those which could be dangerous to personnel. However, this manual cannot possibly anticipate and provide detailed precautions for every situation that might occur during maintenance of the unit. Therefore, it is the responsibility of the owner/maintenance personnel to ensure that **only** safe, established maintenance procedures are used, and that any procedures not addressed in this manual are performed **only** after establishing that neither personal safety nor pump integrity are compromised by such practices.

Many service functions may be performed by draining the pump and removing the back cover assembly. If major repair is required, the piping and/or power source must be disconnected. The following instructions assume complete disassembly is required.

Before attempting to service the pump, disconnect or lock out the power source and take precautions to ensure that it will remain inoperative. Close all valves in the suction and discharge lines.

For engine disassembly and repair, consult the literature supplied with the engine, or contact your local engine representative.



Before attempting to open or service the pump:

1. Familiarize yourself with this manual.
2. Switch off the engine ignition and disconnect the positive battery cable to ensure that the pump will remain inoperative.
3. Allow the pump to completely cool if overheated.
4. Check the temperature before opening any covers, plates, or plugs.
5. Close the suction and discharge valves.
6. Vent the pump slowly and cautiously.
7. Drain the pump.



This pump is designed to handle materials which could cause illness or injury through direct exposure or emitted fumes. Wear adequate protective clothing when working on the pump or piping.



Use lifting and moving equipment in good repair and with adequate capacity to prevent injuries to personnel or damage to equipment.

### Back Cover And Wear Plate Removal

(Figure 3)

The wear plate (12) is easily accessible and may be serviced by removing the back cover assembly (18). Before attempting to service the pump, remove the pump casing drain plug (17) and drain the pump. Clean and reinstall the drain plug.

Remove the back cover nuts (32) and pry the back cover and assembled wear plate from the pump casing (1).

### NOTE

*An alternate method of removing the back cover from the pump casing is to remove the back cover nuts (32) and two diagonally opposing locking collars (29). Install two 1/2–13 UNC x 2 inch long screws in the tapped holes in the back cover and use them to press the back cover out of the pump casing.*

Inspect the wear plate, and replace it if badly scored or worn. To remove the wear plate, disengage the hardware (14 and 15).

Inspect the O-rings (13 and 16) and replace them if damaged or worn.

### Suction Check Valve Removal

#### (Figure 3)

If the check valve assembly (37) is to be serviced, remove the check valve pin (39), reach through the back cover opening and pull the complete assembly from the suction flange (38).

### NOTE

*Further disassembly of the check valve is not required since it must be replaced as a complete unit. Individual parts are not sold separately.*

### Separating Intermediate And Drive Assembly From Engine

#### (Figure 5)

Further disassembly requires separating the pump end and drive assembly from the engine. Install a standard 5/8-11 UNC lifting eye in the tapped hole in the top of the pump casing. **Be sure** to screw the eye into the casing until fully engaged. Support the pump using a suitable hoist and the lifting eye.



**Do not attempt to lift the complete pump unit using the lifting eye. It is designed**

**to facilitate removal or installation of individual components only. Additional weight may result in damage to the pump or failure of the eye bolt.**

Remove the hardware securing the pump casing to the base.

Disengage the hardware (6 and 7) securing the drive flange to the engine bellhousing, and remove the guards (28, Figure 4). Separate the pump end and drive assembly from the engine by pulling the pump end straight away from the engine.

As the assemblies separate, the flexible portion of the coupling assembly (3) will remain on the shaft. To remove the coupling from the shaft, unscrew the two allen head setscrews from the bushing (2). Screw one of the setscrews into the puller hole on the circumference of the bushing. As the coupling and bushing separate, remove the bushing, and slide the coupling off the shaft. Remove the shaft key (11, Figure 4).

It is not necessary to remove the outer ring of the coupling from the engine flywheel unless the coupling must be replaced. To remove the ring, disengage the hardware (4 and 5) securing it to the flywheel.

Remove any leveling shims used under the casing mounting feet. Tie and tag the shims for ease of reassembly.

Move the pump end to a clean, well-equipped shop area for further disassembly.

### Loosening Impeller

#### (Figure 4)

Before attempting to loosen the impeller, remove the seal cavity drain plug (23) and drain the lubricant. This will prevent the oil from escaping as the impeller is removed. Clean and reinstall the drain plug.

With the pump end separated from the engine and the back cover (18, Figure 3) removed, wedge a block of wood between the vanes of the impeller and the pump casing to prevent rotation.

If removed, install the shaft key (11) in the shaft keyway. Install a lathe dog on the drive end of the

shaft (12) with the “V” notch positioned over the shaft key.

With the impeller rotation still blocked, see Figure 6 and use a long piece of heavy bar stock to pry against the arm of the lathe dog in a counterclockwise direction (when facing the drive end of the shaft). **Use caution** not to damage the shaft or keyway. When the impeller breaks loose, remove the lathe dog, key and wood block.

### NOTE

*Do not remove the impeller until the rotating assembly has been removed from the pump casing.*

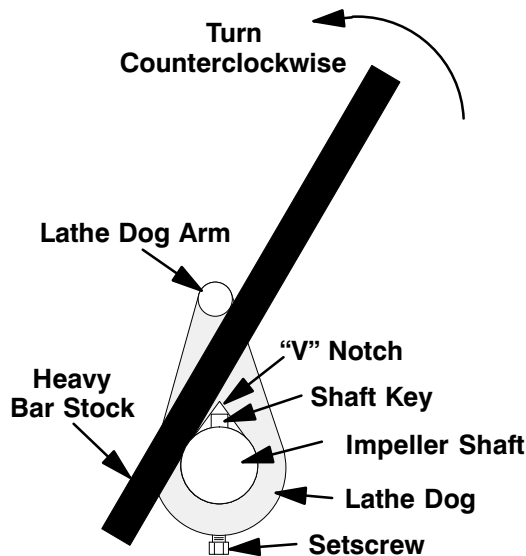

Figure 6. Loosening Impeller

### Rotating Assembly Removal (Figure 4)

Remove the hardware (9 and 10, Figure 3) securing the rotating assembly to the pump casing. Separate the rotating assembly by pulling straight away from the pump casing. Tie and tag the rotating assembly shims (11) for ease of reassembly.

### NOTE

*An optional disassembly tool is available from the factory. If the tool is used, follow the instructions packed with it. A similar tool may be assembled using 1/2-inch pipe (schedule 80 steel or malleable iron) and a standard tee (see Figure 7). All threads are 1/2-inch NPT. **Do not pre-assemble the tool.***

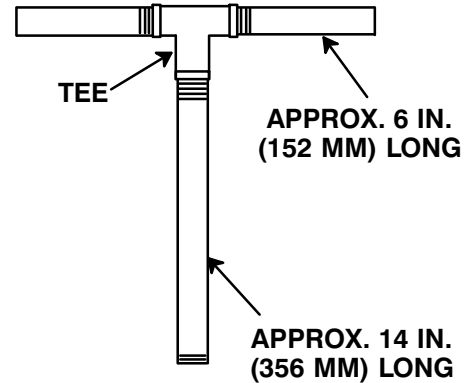

Figure 7. Rotating Assembly Tool

*To install the tool, remove the vented plug (6, Figure 4) from the bearing housing, and screw the longest length of pipe into the vent hole until fully engaged. Install the tee, and screw the handles into the tee. Use caution when lifting the rotating assembly to avoid injury to personnel or damage to the assembly.*

Remove the bearing housing O-ring (33).

### Impeller Removal (Figure 4)

With the rotating assembly removed from the pump casing, unscrew the impeller from the shaft. Use caution when unscrewing the impeller; tension on the shaft seal spring will be released as the impeller is removed. Inspect the impeller and replace if cracked or badly worn.

Remove the impeller adjusting shims (29); tie and tag the shims, or measure and record their thickness for ease of reassembly.

### Seal Removal (Figure 4)

Slide the integral shaft sleeve and rotating portion of the seal off the shaft as a unit.

Use a pair of stiff wires with hooked ends to remove the stationary element and seat.

An alternate method of removing the stationary seal components is to remove the hardware (20 and 21) and separate the seal plate (22) and gas-

ket (3) from the bearing housing (5). Position the seal plate on a flat surface with the impeller side down. Use a wooden dowel or other suitable tool to press on the back side of the stationary seat until the seat, O-rings, and stationary element can be removed.

Remove the shaft sleeve O-ring (30).

If no further disassembly is required, refer to **Seal Installation**.

### Shaft and Bearing Removal and Disassembly

(Figure 4)

When the pump is properly operated and maintained, the bearing housing should not require disassembly. Disassemble the shaft and bearings **only** when there is evidence of wear or damage.



Shaft and bearing disassembly in the field is not recommended. These operations should be performed only in a properly-equipped shop by qualified personnel.

Remove the bearing housing drain plug (24) and drain the lubricant. Clean and reinstall the drain plug.

Disengage the hardware (15 and 16) and slide the drive flange (10) and oil seal (13) off the shaft. Remove the flange gasket (17) and press the oil seal from the drive flange.

Place a block of wood against the impeller end of the shaft and tap the shaft and assembled bearings (4 and 9) from the bearing housing.

Pry or press the oil seals (18 and 19) from the bearing housing.

After removing the shaft and bearings, clean and inspect the bearings **in place** as follows.



To prevent damage during removal from the shaft, it is recommended that bearings be cleaned and inspected **in place**. It is **strongly** recommended that the bearings be replaced **any** time the shaft and bearings are removed.

Clean the bearing housing, shaft and all component parts (except the bearings) with a soft cloth soaked in cleaning solvent. Inspect the parts for wear or damage and replace as necessary.



**Most cleaning solvents are toxic and flammable. Use them only in a well ventilated area free from excessive heat, sparks, and flame. Read and follow all precautions printed on solvent containers.**

Clean the bearings thoroughly in **fresh** cleaning solvent. Dry the bearings with filtered compressed air and coat with light oil.



Bearings must be kept free of all dirt and foreign material. Failure to do so will greatly shorten bearing life. **Do not** spin dry bearings. This may scratch the balls or races and cause premature bearing failure.

Rotate the bearings by hand to check for roughness or binding and inspect the bearing balls. If rotation is rough or the bearing balls are discolored, replace the bearings.

The bearing tolerances provide a tight press fit onto the shaft and a snug slip fit into the bearing housing. Replace the bearings, shaft, or bearing housing if the proper bearing fit is not achieved.

If bearing replacement is required, remove the outboard bearing snap ring (14), and use a bearing puller to remove the bearings from the shaft.

### Shaft and Bearing Reassembly and Installation

#### (Figure 4)

Clean the bearing housing, shaft and all component parts (except the bearings) with a soft cloth soaked in cleaning solvent. Inspect the parts for wear or damage as necessary.



**Most cleaning solvents are toxic and flammable. Use them only in a well ventilated area free from excessive heat, sparks, and flame. Read and follow all precautions printed on solvent containers.**

Inspect the shaft for distortion, nicks or scratches, or for thread damage on the impeller end. Dress small nicks and burrs with a fine file or emery cloth. Replace the shaft if defective.

Position the inboard oil seal (18) in the bearing housing bore with the lip positioned as shown in Figure 4. Press the oil seal into the housing until the face is **just flush** with the machined surface on the inside of the housing.



To prevent damage during removal from the shaft, it is recommended that bearings be cleaned and inspected **in place**. It is **strongly** recommended that the bearings be replaced **any** time the shaft and bearings are removed.

#### NOTE

*Position the inboard bearing (4) on the shaft with the shielded side toward the impeller end of the shaft. Position the outboard bearing (9) on the shaft with the integral retaining ring on the bearing O.D. toward the drive end of the shaft.*

The bearings may be heated to ease installation. An induction heater, hot oil bath, electric oven, or hot plate may be used to heat the bearings. Bearings should **never** be heated with a direct flame or directly on a hot plate.

#### NOTE

*If a hot oil bath is used to heat the bearings, both the oil and the container must be **absolutely** clean. If the oil has been previously used, it must be **thoroughly** filtered.*

Heat the bearings to a uniform temperature **no higher than 250°F (120°C)**, and slide the bearings onto the shaft, one at a time, until they are fully seated. This should be done quickly, in one continuous motion, to prevent the bearings from cooling and sticking on the shaft.

After the bearings have been installed and allowed to cool, check to ensure that they have not moved away from the shaft shoulders in shrinking. If movement has occurred, use a suitably sized sleeve and a press to reposition the bearings against the shaft shoulders.

If heating the bearings is not practical, use a suitably sized sleeve, and an arbor (or hydraulic) press to install the bearings on the shaft.



When installing the bearings onto the shaft, **never** press or hit against the outer race, balls, or ball cage. Press **only** on the inner race.

Secure the outboard bearing on the shaft with the bearing snap ring (14).

It is recommended that a sleeve be positioned against the inboard oil seal (18) to prevent the lip of the oil seal from rolling as the shaft and bearings are installed in the bearing housing. The O.D. of the sleeve should be just smaller than the bearing housing bore, while the I.D. of the sleeve should be just larger than the O.D. of the lip seal area of the shaft.

With the lip seal sleeve in place, lubricate the lip seal area of the shaft, and slide the shaft and assembled bearings into the bearing housing until

the retaining ring on the outboard bearing seats against the bearing housing. Remove the lip seal sleeve.

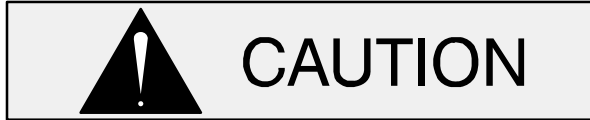

When installing the shaft and bearings into the bearing bore, push against the outer race. **Never** hit the balls or ball cage.

Position the outboard oil seal (19) on the lubricated shaft with the lip positioned as shown in Figure 4. Press the oil seal into the bearing housing until the face of the seal is **just flush** with the machined surface on the bearing housing.

Press the oil seal (13) into the drive flange (10) with the lip positioned as shown in Figure 4. Replace the flange gasket (17), and secure the flange to the bearing housing with the hardware (15 and 16). **Be careful** not to damage the oil seal lip on the shaft keyway.

Lubricate the bearing housing as indicated in **LUBRICATION**.

#### Seal Installation

(Figures 4, 8, 9 and 10)



**Most cleaning solvents are toxic and**

**flammable. Use them only in a well ventilated area free from excessive heat, sparks, and flame. Read and follow all precautions printed on solvent containers.**

Clean the seal cavity and shaft with a cloth soaked in fresh cleaning solvent. Inspect the stationary seat bore in the seal plate for dirt, nicks and burrs, and remove any that exist. The stationary seat bore **must** be completely clean before installing the seal.

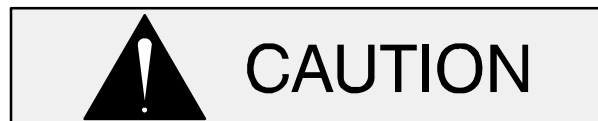

A new seal assembly should be installed **any time** the old seal is removed from the pump. Wear patterns on the finished faces cannot be realigned during reassembly. Reusing an old seal could result in premature failure.

To ease installation of the seal, lubricate the shaft sleeve O-ring (30) and the external stationary seat O-ring with a very **small** amount of light lubricating oil. See Figure 8 for seal part identification.



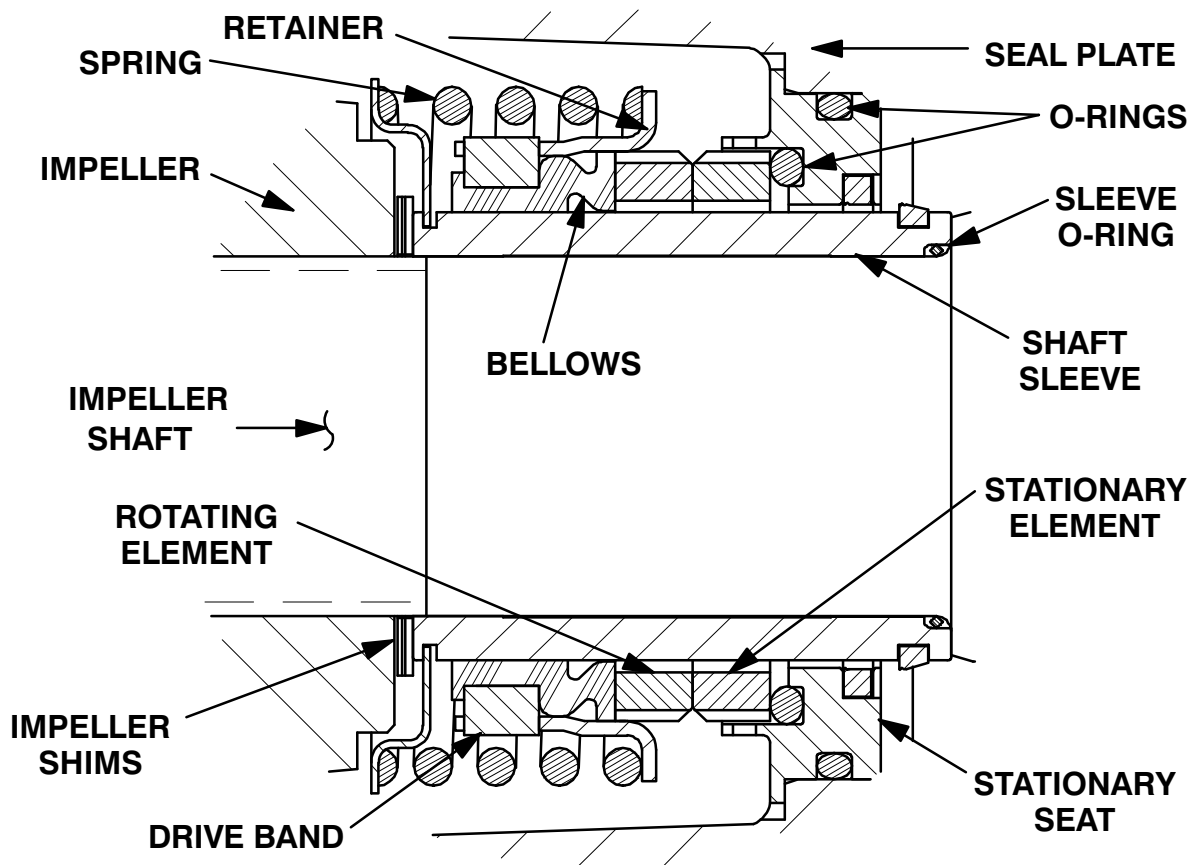
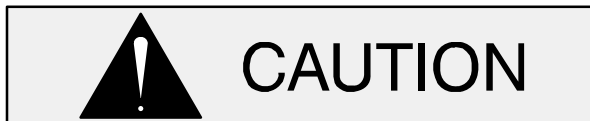

Figure 8. 46513-159 Cartridge Seal Assembly



This seal is not designed for operation at temperatures above 160°F (71°C). Do not use at higher operating temperatures.

If the seal plate (22) was removed, install the seal plate gasket (3). Position the seal plate over the shaft and secure it to the bearing housing with the hardware (20 and 21). Install the bearing housing O-ring (33) and lubricate it with light grease.

To prevent damaging the shaft sleeve O-ring (30) on the shaft threads, stretch the O-ring over a piece of tubing 1-1/2 I.D. x 1-3/4 O.D. x 2-inches long (38 mm x 43 mm x 51 mm). Slide the tube over the shaft threads, then slide the O-ring off the tube and onto the shaft. Remove the tube, and continue to slide the O-ring down the shaft until it seats against the shaft shoulder.

**When installing a new cartridge seal assembly,** remove the seal from the container, and remove

the mylar storage tabs, if so equipped, from between the seal faces.



New cartridge seal assemblies may be equipped with mylar storage tabs between the seal faces. If so equipped, these storage tabs **must** be removed before installing the seal.

Lubricate the external stationary seat O-ring with light oil. Slide the seal assembly onto the shaft until the external stationary seat O-ring engages the bore in the seal plate.

Clean and inspect the impeller as described in **Impeller Installation and Adjustment**. Install the full set of impeller shims (29) provided with the seal, and screw the impeller onto the shaft until it is seated against the seal (see Figure 9).

Continue to screw the impeller onto the shaft. This will press the stationary seat into the seal plate bore.

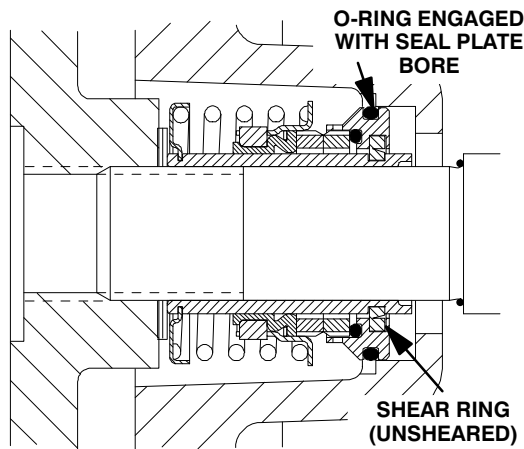

Figure 9. Seal Partially Installed

**NOTE**

*A firm resistance will be felt as the impeller presses the stationary seat into the seal plate bore.*

As the stationary seat becomes fully seated, the seal spring compresses, and the shaft sleeve will break the nylon shear ring. This allows the sleeve to slide down the shaft until seated against the shaft shoulder. Continue to screw the impeller onto the shaft until the impeller, shims, and sleeve are fully seated against the shaft shoulder (see Figure 10).

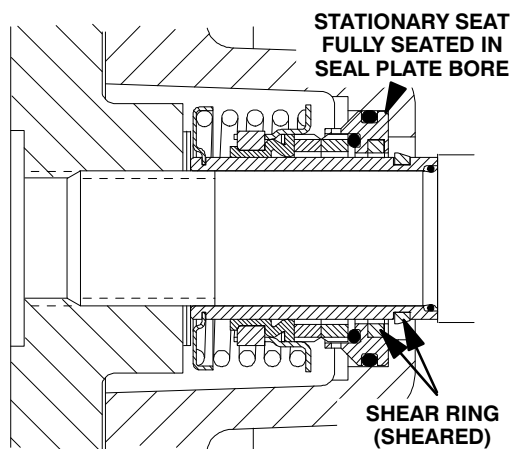
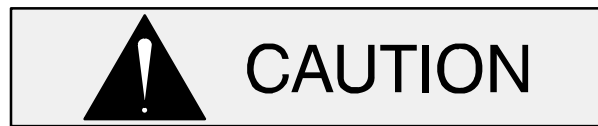

Figure 10. Seal Fully Installed

Measure the impeller-to-seal plate clearance, and remove impeller adjusting shims to obtain the proper clearance as described in **Impeller Installation and Adjustment**.

If necessary to reuse an old seal in an emergency, carefully separate the rotating and stationary seal faces from the bellows retainer and stationary seat.



A new seal assembly should be installed **any time** the old seal is removed from the pump. Wear patterns on the finished faces cannot be realigned during reassembly. Reusing an old seal could result in premature failure.

Handle the seal parts with extreme care to prevent damage. Be careful not to contaminate precision finished faces; even fingerprints on the faces can shorten seal life. If necessary, clean the faces with a non-oil based solvent and a clean, lint-free tissue. Wipe **lightly** in a concentric pattern to avoid scratching the faces.

**Carefully** wash all metallic parts in fresh cleaning solvent and allow to dry thoroughly.



**Do not** attempt to separate the rotating portion of the seal from the shaft sleeve when reusing an old seal. The rubber bellows will adhere to the sleeve during use, and attempting to separate them could damage the bellows.

Inspect the seal components for wear, scoring, grooves, and other damage that might cause leakage. Inspect the integral shaft sleeve for nicks or cuts on either end. If any components are worn, or the sleeve is damaged, replace the complete seal; **never mix old and new seal parts**.

Install the stationary seal element in the stationary seat. Press this stationary subassembly into the seal plate bore until it seats squarely against the bore shoulder. A push tube made from a piece of plastic pipe would aid this installation. The I.D. of the pipe should be slightly larger than the O.D. of the shaft sleeve.

Slide the rotating portion of the seal (consisting of the integral shaft sleeve, spring centering washer, spring, bellows and retainer, and rotating element) onto the shaft until the seal faces contact.

Proceed with **Impeller Installation and Adjustment**.

### Impeller Installation

(Figure 4)

Inspect the impeller, and replace it if cracked or badly worn. Inspect the impeller and shaft threads for dirt or damage, and clean or dress the threads as required.



The shaft and impeller threads **must** be completely clean before reinstalling the impeller. Even the slightest amount of dirt on the threads can cause the impeller to seize to the shaft, making future removal difficult or impossible without damage to the impeller or shaft.

Install the same thickness of impeller adjusting shims (29) as previously removed. Apply 'Never-Seez' or equivalent to the shaft threads and screw the impeller onto the shaft until tight. Be sure the seal spring seats squarely on the back side of the impeller.

#### NOTE

*At the slightest sign of binding, immediately back the impeller off, and check the threads for dirt. Do not try to force the impeller onto the shaft.*

A clearance of .025 to .040 inch (0,64 to 1,02 mm) between the impeller and the seal plate is recommended for maximum pump efficiency. Measure this clearance, and add or remove impeller adjusting shims as required.

#### NOTE

*If the rotating assembly has been installed in the pump casing, this clearance may be measured by reaching through the priming port with a feeler gauge.*

### Rotating Assembly Installation

(Figure 3)

#### NOTE

*If the pump has been completely disassembled, it is recommended that the suction check valve and back cover assembly be reinstalled at this point. The back cover assembly must be in place to adjust the impeller face clearance.*

Install the bearing housing O-ring (33) and lubricate it with light grease. Ease the rotating assembly into the pump casing using the installation tool. **Be careful** not to damage the O-ring.

Install the rotating assembly adjusting shims (13) using the same thickness as previously removed. Secure the rotating assembly to the pump casing with the hardware (11 and 12).

To set the impeller and wear plate clearance refer to the **Back Cover Installation And Adjustment**.

### Suction Check Valve Installation

(Figure 3)

Inspect the check valve assembly (37) and replace it if badly worn.

#### NOTE

*The check valve assembly must be replaced as a complete unit. Individual parts are not sold separately.*

Reach through the back cover opening with the check valve and position the check valve adaptor in the mounting slot in the suction flange (38). Align the adaptor with the flange hole and secure the assembly with the check valve pin (39).

#### NOTE

*If the suction or discharge flanges were removed, replace the respective gaskets, apply 'Permatex Aviation No. 3 Form-A-Gasket' or equivalent compound to the mating surfaces, and secure them to the pump casing with the attaching hardware.*

### Back Cover Installation And Adjustment

(Figures 3 and 11)

If the wear plate (12) was removed for replacement, carefully center it on the back cover and se-

cure it with the hardware (14 and 15). The wear plate **must** be concentric to prevent binding when the back cover is installed.

The clearance between the impeller and wear plate is adjusted using four adjusting screws (30) and locking collars (29). There are 18 detents on the I.D. of each locking collar. Indexing the collars one detent on the adjusting screws represents approximately .005 inch (0,13 mm) of wear plate clearance. The recommended clearance between the wear plate and the impeller is .010 to .020 inch (0,25 to 0,50 mm).

Replace the O-rings (13 and 16) and lubricate them with a generous amount of No. 2 grease. Clean any scale or debris from the contacting surfaces in the pump casing that might interfere or prevent a good seal with the back cover.

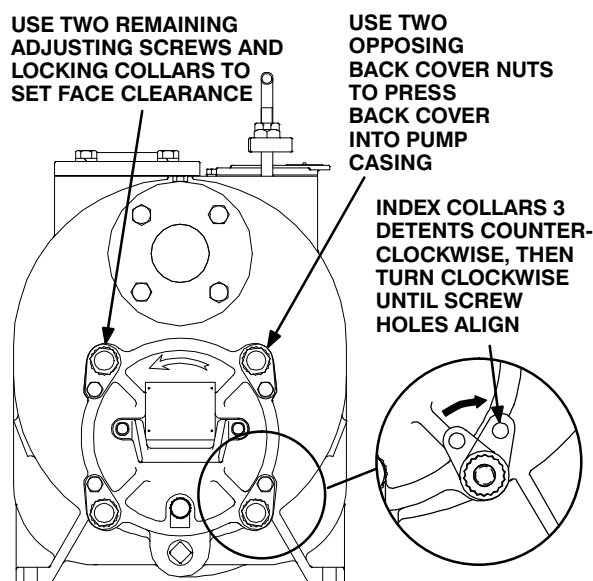

**Figure 11. Installing and Adjusting Back Cover**

Screw the four adjusting screws (30) into the tapped holes in the back cover plate until they are **just flush** with the machined surface on the back side of the cover plate.

Align the back cover plate over the studs (31) and slide it into the pump casing. Use two back cover nuts (32) on diagonally opposing studs to press the back cover into the pump casing until the wear plate **just touches** the impeller when the shaft is turned by hand. **Tighten the back cover nuts evenly to avoid binding.**

With the wear plate just touching the impeller, turn the two free adjusting screws until they engage the pump casing. Position the locking collars over the adjusting screws so the holes in the collars for the locking screws align approximately with the holes in the cover plate.

Loosen the back cover nuts used to press the back cover into the pump casing one full turn.

Pull the collars off the adjusting screws, index them three detents counterclockwise, and reinstall the collars on the adjusting screws. Use the collars to turn the adjusting screws clockwise until the holes in the locking collars realign with the tapped screw holes in the back cover plate. Secure the locking collars to the back cover plate with the hardware (27 and 28). Install the two remaining back cover nuts snugly against the adjusting screws.

Remove the first two back cover nuts from their studs. Turn the adjusting screws clockwise until they engage the pump casing. Install the locking collars and hardware (27 and 28). Reinstall the back cover nuts.

Be sure the wear plate does not scrape against the impeller.

Over time it may be necessary to repeat the adjustment process to compensate for normal wear between the impeller and wear plate. When all of the adjustment has been used on the back cover side of the pump, an additional 0.125 inch (3,2 mm) of adjustment may be obtained by removing the rotating assembly adjusting shims (11).

Allow an installed pump to completely cool before draining liquid from the pump casing. Remove the back cover. Remove the rotating assembly adjusting shims, then reinstall the hardware securing the rotating assembly to the pump casing. Perform the back cover adjustment procedure described above to obtain the proper face clearance.

### Securing Pump End To Engine

(Figure 5)

Install the shaft key (11, Figure 4) in the shaft keyway. Position the flexible portion of the coupling assembly (3) on the shaft as shown in Figure 5.

Align the keyway in the bushing (2) with the shaft key, and slide it onto the shaft to the dimension

shown in Figure 5. Rotate the flexible portion of the coupling until the tapped holes for the two setscrews align with those in the bushing, and install the setscrews.



Make certain that the flexible portion of the coupling is mounted as shown in Figure 5. **This is critical.** If the coupling is not properly positioned on the shaft, the coupling parts may not fully engage, or a pre-load condition can cause premature bearing failure.

The end of the shaft must protrude 1.25 inch (32 mm) from the face of the bushing. This will allow the two portions of the coupling to fully engage when the drive flange is secured to the engine bellhousing, without pre-loading the bearings.

With the flexible portion of the coupling and the bushing properly positioned on the shaft, tighten the two setscrews in an alternating sequence until the bushing and coupling are fully secured. Torque the setscrews to 14.6 ft. lbs. (175 in. lbs. or 2 m. kg.).

If the complete coupling assembly is being replaced, apply 'Loctite Retaining Compound No. 242' or equivalent to the threads of the hardware (4 and 5), and secure the outer ring of the coupling to the engine flywheel by torquing the hardware to 45 ft. lbs. (540 in. lbs. or 6,2 m. kg.).

Using a suitable lifting device, position the pump end so the flexible portion of the coupling seats inside the outer ring attached to the engine flywheel.

#### NOTE

To ease installation, **lightly** lubricate the rubber portion of the coupling with a **non-petroleum based lubricant** such as vegetable oil or glycerin, or a silicon-based lubricant such as "WD40" or equivalent. **Do not** use petroleum-based lubricants, or any other substance which may soften or otherwise dam-

age the rubber.

Install the intermediate guards (28, Figure 4), and secure the drive flange to the engine bellhousing with the hardware (6 and 7).

(Figure 1)

Install any leveling shims used under the casing mounting feet, and secure the casing to the base with the previously removed hardware.

If a lifting eye was used to move the pump casing, **be sure** to remove the lifting eye from the pump casing.



**Do not attempt to lift the complete pump unit using the lifting eye. It is designed to facilitate removal or installation of individual components only. Additional weight may result in damage to the pump or failure of the eye bolt.**

#### PRESSURE RELIEF VALVE MAINTENANCE

(Figure 3)

The back cover is equipped with a pressure relief valve (19) to provide additional safety for the pump and operator (refer to **Liquid Temperature And Overheating** in **OPERATION**).

It is recommended that the pressure relief valve assembly be replaced at each overhaul, or any time the pump overheats and activates the valve. **Never** replace this valve with a substitute which has not been specified or provided by the Gorman-Rupp Company.

Periodically, the valve should be removed for inspection and cleaning. When reinstalling the relief valve, apply 'Loctite Pipe Sealant With Teflon No. 592', or equivalent compound, on the relief valve threads. Position the valve as shown in Figure 3 with the discharge port pointing down.

## Final Pump Assembly

### (Figure 1)

**Be sure** the pump is secured to the base and engine. Be sure to install any guards used over the rotating members.



**Do not operate the pump without the guards in place over the rotating parts. Exposed rotating parts can catch clothing, fingers, or tools, causing severe injury to personnel.**

Install the suction and discharge lines and open all valves. Make certain that all piping connections are tight, properly supported and secure.

**Be sure** the pump and engine have been properly lubricated, see **LUBRICATION**.

Remove the fill cover assembly (44, Figure 3) and fill the pump casing with clean liquid. Reinstall the fill cover and tighten it. Refer to **OPERATION**, Section C, before putting the pump back into service.

## LUBRICATION

### Seal Assembly

#### (Figure 4)

Before starting the pump, remove the vented plug (6) and fill the seal cavity with approximately 88 ounces (2,6 liter) of SAE No. 30 non-detergent oil to the middle of the sight gauge (26) and maintain it at the middle of the gauge. Clean and reinstall the vented plug. Maintain the oil at this level.

#### NOTE

*The white reflector in the sight gauge must be positioned horizontally to provide proper drainage.*

## Bearings

### (Figure 4)

The bearing housing was fully lubricated when shipped from the factory. Check the oil level regularly through the sight gauge (25) and maintain it at the middle of the gauge. When lubrication is required, add SAE No. 30 non-detergent oil through the hole for the air vent (7). **Do not** over-lubricate. Over-lubrication can cause the bearings to over-heat, resulting in premature bearing failure.

#### NOTE

*The white reflector in the sight gauge must be positioned horizontally to provide proper drainage.*

Under normal conditions, drain the bearing housing once each year and refill with approximately 24 ounces (0,7 liter) clean oil. Change the oil more frequently if the pump is operated continuously or installed in an environment with rapid temperature change.



Monitor the condition of the bearing lubricant regularly for evidence of rust or moisture condensation. This is especially important in areas where variable hot and cold temperatures are common.

For cold weather operation, consult the factory or a lubricant supplier for the recommended grade of oil.

## Engine

Consult the literature supplied with the engine, or contact your local engine representative.

**For U.S. and International Warranty Information,  
Please Visit [www.grpumps.com/warranty](http://www.grpumps.com/warranty)  
or call:  
U.S.: 419-755-1280  
International: +1-419-755-1352**

**For Canadian Warranty Information,  
Please Visit [www.grcanada.com/warranty](http://www.grcanada.com/warranty)  
or call:  
519-631-2870**