

A C D E U



# Priming Assisted Centrifugal Pump w/Autostart

## Model PA4B60-4045H

Size 6" x 4"



Total Head		Capacity of Pump in U.S. Gallons per Minute (GPM) at Continuous Performance			
P.S.I.	Feet				
159.5	368	190	190	190	190
151.7	350	340	340	340	340
130.0	300	430	550	550	550
108.4	250	435	585	688	710
86.7	200	440	595	705	810
65.0	150	450	600	720	840
43.4	100	460	607	730	850
21.7	50	465	615	740	860
<b>Suction Lift</b>		<b>25'</b>	<b>20'</b>	<b>15'</b>	<b>10'</b>

**PUMP SPECIFICATIONS**

**Size:** 6" x 4" (152 mm x 102 mm) Flanged.

**Suction Head:** Gray Iron 30.

**Casing:** Gray Iron 40.

Maximum Operating Pressure 239 psi (1648 kPa).\*

**Enclosed Type, Six Vane Impeller:** Gray Iron 30.

Handles 13/32" (10,4 mm) Diameter Spherical Solids.

**Impeller Shaft:** Stainless Steel 17-4 PH.

**Replaceable Wear Ring:** Copper Alloy C83600.

**Replaceable Balance Ring:** Copper Alloy C83600.

**Intermediate Bracket:** Gray Iron 30.

**Bearing Retainer:** Gray Iron 30.

**Seal:** Mechanical, Oil-Lubricated, Double Floating, Self-Aligning. Silicon Carbide Rotating and Stationary Faces. Stainless Steel 316 Cage, Spring and Stationary Seat. Fluorocarbon Elastomers (DuPont Viton® or Equivalent). Maximum Temperature of Liquid Pumped 160°F (71°C).\*

**Shaft Sleeve:** Stainless Steel 17-4 PH.

**Priming Chamber:** Gray Iron 30 Housing w/Stainless Steel Float and Linkage.

**Discharge Check Valve:** Ductile Iron Housing w/Buna-N Flapper.

**Bearing:** Open Double Row Ball.

**Bearing Lubrication:** Grease.

**Gaskets:** Vegetable Fiber w/Cork and Resistant Synthetic Rubber.

**O-Rings:** Buna-N.

**Hardware:** Standard Plated Steel.

**Seal Oil Reservoir Sight Gauge.**

*\*Consult Factory for Applications Exceeding Maximum Pressure and/or Temperature Indicated.*

**Standard Equipment:** Gear-Driven Air Compressor. Hoisting Bail. Strainer. Combination Skid Base w/Fuel Tank. Single Ball Type Float Switch\*\*.

**Optional Equipment:** Battery. Heated Priming Chamber Kit. Suction and Discharge NPT Threaded Flange Kits. High Speed (55 MPH/89 KM/H) Single Axle Pneumatic-Tired Wheel Kit w/wo DOT-Approved Lights and Electric Brakes. Over-the-Road Trailer (Meets D.O.T. and Transport Canada Requirements) Available w/Either Electric or Hydraulic Surge Brakes, Running Lights, Trailer Jack Stands and Safety Chains/Cables. Two Float Switches. EPS w/Submersible Transducer Liquid Level Sensor. \*\*

*\*\*50 Ft. (15 m) Standard Length; Dual Switches and Alternate Cable Lengths Available From the Factory.*



**WARNING!**  
Do not use in explosive atmosphere or for pumping volatile flammable liquids.

**ENGINE SPECIFICATIONS**

**Model:** John Deere 4045H "Power Tech".

**Type:** Four Cylinder, Turbocharged, Charge Air Cooled, Enclosed, Liquid Cooled Diesel Engine.

**Displacement:** 275 Cu. In. (4,5 liters).

**Governor:** Electronic Isochronous.

**Lubrication:** Forced Circulation.

**Air Cleaner:** Dry Type.

**Oil Reservoir:** 16.7 U.S. Qts. (15,8 liters) Dry; 14.7 U.S. Qts. (13,9 liters) Refill.

**Fuel Tank:** 88 U.S. Gals. (330 liters).

**Full Load Operating Time:** 13.8 Hrs.

**Starter:** 12V Electric.

**Standard Features:** Low Oil Pressure and High Coolant Temperature Safety Shut Down Switches. Autostart Instrument Panel Includes: Tachometer, Voltmeter, Hourmeter, Coolant Temperature Gauge, Oil Pressure Gauge, Manual/Stop/Auto Key Switch, 10 Amp Pushbutton Circuit Breaker, Startup Warning Delay. Muffler w/Weather Cap. Throttle Control.

**JOHN DEERE PUBLISHED PERFORMANCE:**  
Maximum Gross BHP (Incl/Cont. Duty)  
115 (86 kW) @ 2400 RPM



THE GORMAN-RUPP COMPANY • MANSFIELD, OHIO

GORMAN-RUPP OF CANADA LIMITED • ST. THOMAS, ONTARIO, CANADA

www.grpumps.com

Specifications Subject to Change Without Notice

Printed in U.S.A.

**Specification Data**

**SECTION 42, PAGE 405**

APPROXIMATE  
DIMENSIONS and WEIGHTS

**NET WEIGHT:**  
**SHIPPING WEIGHT:**  
**EXPORT CRATE SIZE:**

**SKID BASE**  
3490 LBS. (1583 KGS.)  
3590 LBS. (1628 KGS.)  
245 CU. FT. (6,9 CU. M.)

**2-WHEEL**  
4040 LBS. (1833 KGS.)  
4040 LBS. (1833 KGS.)  
505 CU. FT. (14,3 CU. M.)

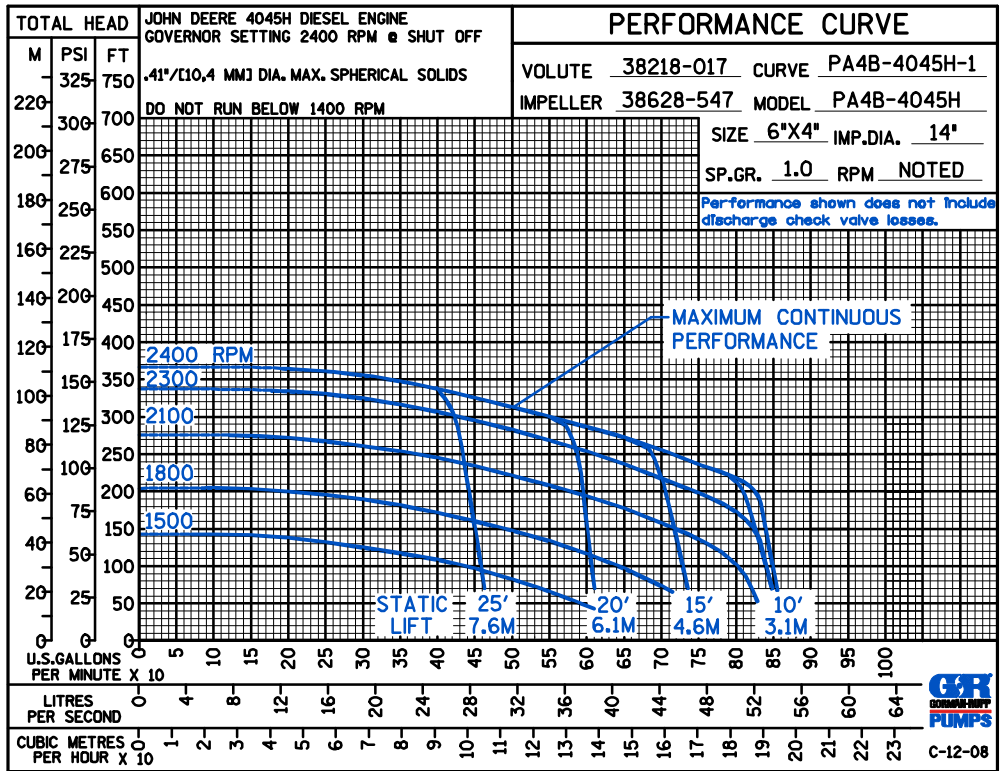
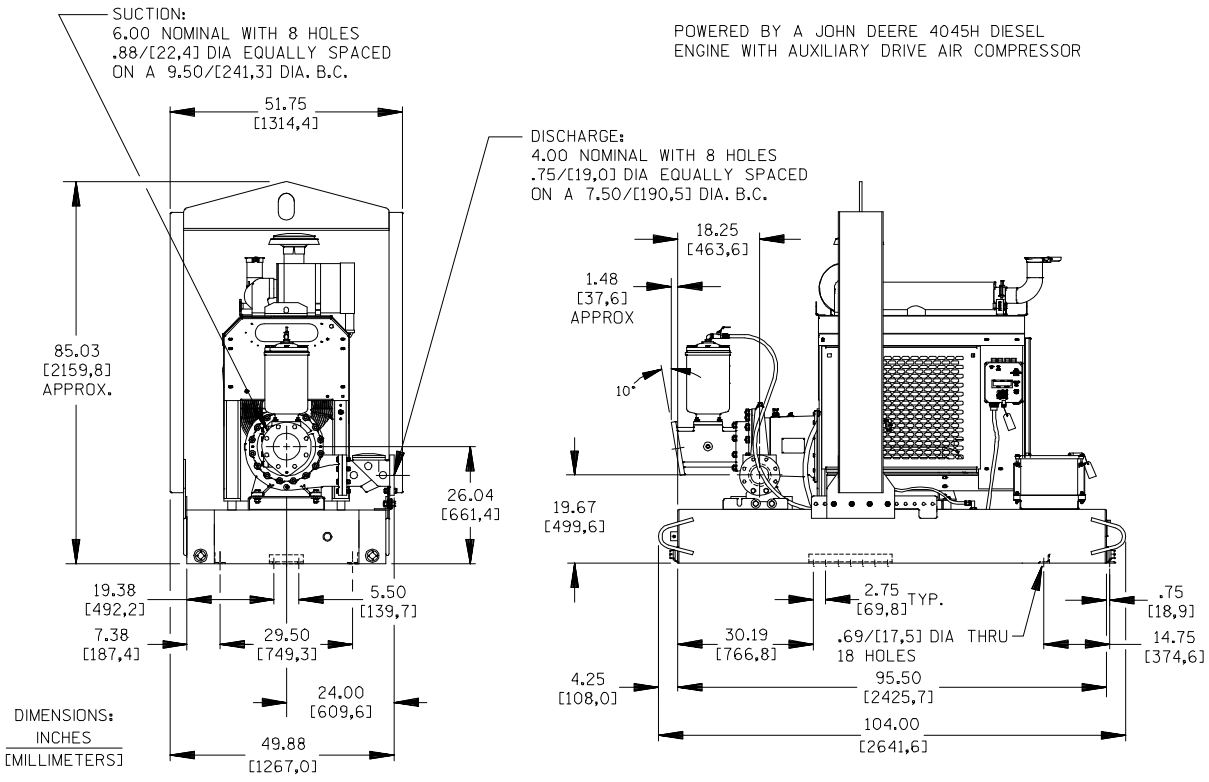

**THE GORMAN-RUPP COMPANY • MANSFIELD, OHIO**

GORMAN-RUPP OF CANADA LIMITED • ST. THOMAS, ONTARIO, CANADA

Specifications Subject to Change Without Notice

Printed in U.S.A.