



**Priming Assisted Centrifugal Pump  
w/Autostart  
Model PAH8A65-6090H  
Size 10" x 8"**



Total Head		Capacity of Pump in U.S. Gallons per Minute (GPM) at Continuous Performance			
P.S.I.	Feet				
133.5	308	950	950	950	950
121.4	280	1650	1650	1650	1650
104.0	240	1950	3000	3200	3200
86.7	200	1950	3100	3850	4250
69.4	160	1950	3100	4000	4600
52.0	120	1950	3100	4000	4825
34.7	80	1950	3100	4025	4900
17.3	40	1950	3100	4050	4900
<b>Suction Lift</b>		<b>25'</b>	<b>20'</b>	<b>15'</b>	<b>10'</b>



**PUMP SPECIFICATIONS**

- Size:** 10" x 8" (254 mm x 203 mm) Flanged.
- Casing:** Stainless Steel CD4MCu.
- Maximum Operating Pressure 222 psi (1531 kPa).\*
- Enclosed Type, Two Vane Impeller:** Stainless Steel CD4MCu.
- Handles 3" (76.2 mm) Diameter Spherical Solids.
- Suction Head:** Stainless Steel CD4MCu.
- Suction Spool:** Stainless Steel CD4MCu.
- Impeller Shaft:** Stainless Steel 17-4 PH.
- Replaceable Wear Ring:** Stainless Steel CD4MCu.
- Bearing Pedestal:** Gray Iron 30.
- Seal Plate:** Stainless Steel CD4MCu.
- Seal:** Mechanical, SAE 30 Non-Detergent Oil Lubricated. Silicon Carbide Rotating Face and Stationary Seat. Fluorocarbon Elastomers (DuPont Viton® or Equivalent). Stainless Steel 316 Cage and Stainless Steel 316 Spring. Maximum Temperature of Liquid Pumped 160° F (71° C).\*
- Shaft Sleeve:** Stainless Steel 17-4 PH.
- Priming Chamber:** Stainless Steel 316 Housing w/Stainless Steel Float and Linkage.
- Discharge Check Valve:** Stainless Steel Housing w/Viton Flapper.
- Radial Bearing:** Open Roller.
- Thrust Bearing:** Open Double Ball.
- Bearing Cavity Lubrication:** Lithium EP2 Grease.
- Gaskets:** Fluorocarbon (DuPont Viton® or Equivalent), Compressed Synthetic Fibers and Buna-N.
- O-Rings:** Fluorocarbon (DuPont Viton® or Equivalent).
- Hardware:** Stainless Steel 316 and 17-4 PH.
- Seal Cavity Oil Level Sight Gauges.**
- \*Consult Factory for Applications Exceeding Maximum Pressure and/or Temperature Indicated.
- Standard Equipment:** Strainer. Gear-Driven Air Compressor. Hoisting Bail. Combination Skid Base w/Fuel Tank. [Single Ball Type Float Switch](#).\*\*
- Optional Equipment:** Battery Threaded Flange Kit. Suction Vacuum and Discharge Pressure Gauge Kit. [Tandem Axle Over-the-Road Trailer](#). [Full Feature Control Panel](#) For Use w/Submersible Transducer Liquid Level Sensor\*\*
- \*\*50 Ft. (15 m) Standard Length; Dual Switches and Alternate Cable Lengths Available From the Factory.

**WARNING!**  
Do not use in explosive atmosphere or for pumping volatile flammable liquids.

**ENGINE SPECIFICATIONS**

- Model:** John Deere 6090H "Power Tech."
- EPA Tier:** Tier 3.
- Type:** Six Cylinder, Four Cycle, Charge Air Cooled, Enclosed, Liquid Cooled Diesel Engine.
- Displacement:** 548 Cu. In. (9,0 liters).
- Governor:** Electronic Isochronous.
- Lubrication:** Forced Circulation.
- Air Cleaner:** Dry Type.
- Fuel Tank:** 262 U.S. Gals. (992 liters).
- Full Load Operating Time:** 17.9 Hrs.
- Starter:** 12V Electric.
- Standard Features:** Muffler w/Weather Cap.
- Optional Features:** Electronic Fuel Level Sensor.
- Engine Control Features:** Padlockable Box with Throttle Control, Tachometer, Coolant Temperature, Oil Pressure, Voltage and Overstart Indicators/Shut-downs. Manual/Stop/Auto Keyswitch. Audible Start-up Warning Delay. Fuel Level Display/Alarm/Shut-down (For Use With Optional Fuel Level Sensor).

**JOHN DEERE PUBLISHED PERFORMANCE:**  
Maximum Gross BHP (Intermittent)  
375 (280 kW) @ 2200 RPM



**GORMAN-RUPP PUMPS**

www.grpumps.com

Specifications Subject to Change Without Notice

Printed in U.S.A.

**Specification Data**

SECTION 43, PAGE 411

APPROXIMATE DIMENSIONS and WEIGHTS

NET WEIGHT:  
SHIPPING WEIGHT:  
EXPORT CRATE SIZE:

SKID BASE  
9200 LBS. (4173 KG.)  
9600 LBS. (4354 KG.)  
719 CU. FT. (20 CU. M.)

WHEEL KIT  
9700 LBS. (4400 KG.)  
9700 LBS. (4400 KG.)

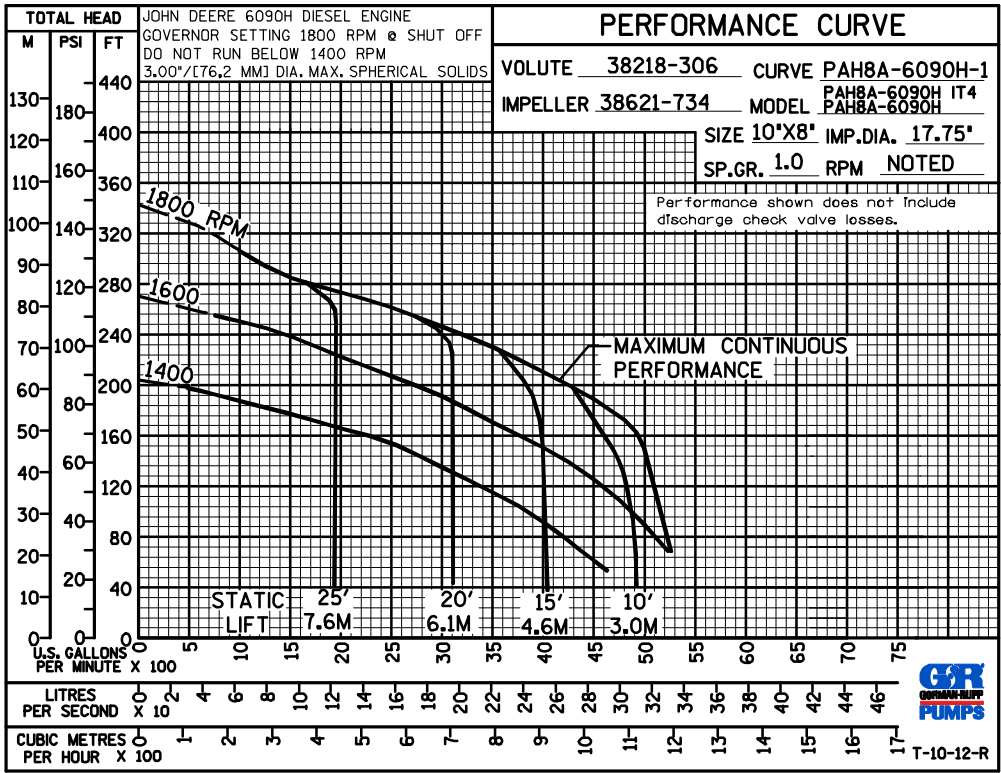
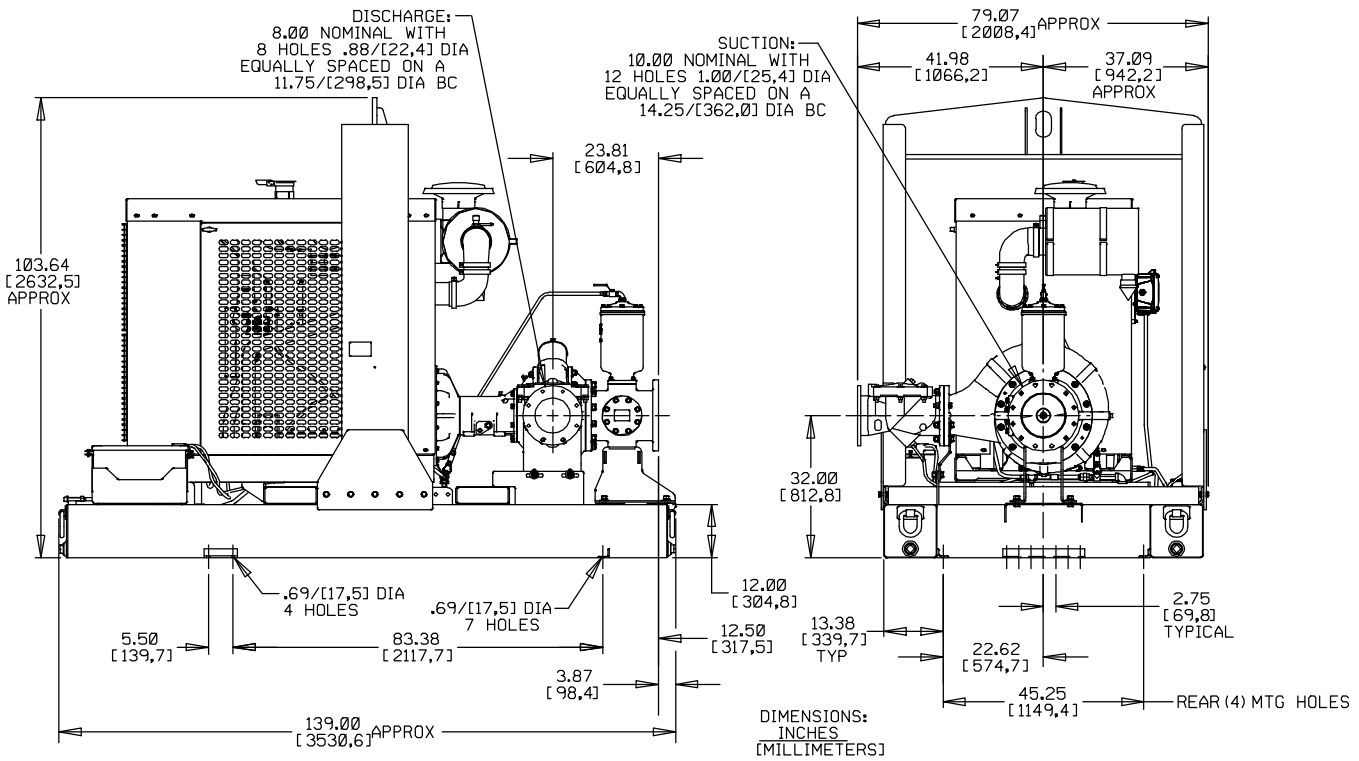

**GORMAN-RUPP PUMPS**

www.grpumps.com

Specifications Subject to Change Without Notice

Printed in U.S.A.