



***PRIME-AIRE*<sup>®</sup> SERIES**  
**12-INCH PUMPS**

**MANUAL**  
**PART 3 of 3**

**MAINTENANCE**  
**AND**  
**REPAIR**  
**WITH**  
**TROUBLESHOOTING**

**THE GORMAN-RUPP COMPANY • MANSFIELD, OHIO**

[www.grpumps.com](http://www.grpumps.com)

**GORMAN-RUPP OF CANADA LIMITED • ST. THOMAS, ONTARIO, CANADA** Printed in U.S.A.

©2004 The Gorman-Rupp Company

Register your new  
Gorman-Rupp pump online at  
**[www.grpumps.com](http://www.grpumps.com)**

Valid serial number and e-mail address required.



**The engine exhaust from this product contains chemicals known to the State of California to cause cancer, birth defects or other reproductive harm.**

### **RECORD YOUR PUMP MODEL AND SERIAL NUMBER**

Please record your pump model and serial number in the spaces provided below. Your Gorman-Rupp distributor needs this information when you require parts or service.

Pump Model: \_\_\_\_\_

Serial Number: \_\_\_\_\_

## INTRODUCTION

**Thank You** for purchasing a Gorman-Rupp Prime-Aire® Series priming-assisted pump. **Read this manual** carefully to learn how to safely maintain and service your pump. Failure to do so could result in personal injury or damage to the pump.

A set of three manuals accompanies your pump. The Installation/Operation Manual contains essential information on installing and operating the pump, and on making electrical connections. The Parts List Manual provides performance curve(s), a pump model cross-section drawing, and parts list for your pump.

This Maintenance and Repair Manual provides troubleshooting instructions required to properly diagnose operational problems. Maintenance instructions within this manual are limited to the pump hydraulic and drive components only. For maintenance and repair of the engine or air compressor, consult the separate literature provided by the manufacturers.

This pump is a PA Series, priming-assisted centrifugal model. The unit is designed for handling non-volatile, non-flammable liquids containing specified entrained solids. For specific service, contact your Gorman-Rupp distributor or the Gorman-Rupp Company.

This manual will alert personnel to known procedures which require special attention, to those which could damage equipment, and to those which could be dangerous to personnel. However, this manual cannot possibly anticipate and provide detailed precautions for every situation that might occur during maintenance of the unit. Therefore, it is the responsibility of the owner/maintenance personnel to ensure that **only** safe, established maintenance procedures are used, and that any procedures not addressed in this manual are performed **only** after establishing that neither personal safety nor pump integrity are compromised by such practices.

If there are any questions regarding the pump which are not covered in this manual or in other literature accompanying the unit, please contact your Gorman-Rupp distributor or the Gorman-Rupp Company:

**The Gorman-Rupp Company**  
**P.O. Box 1217**  
**Mansfield, Ohio 44901-1217**  
**Phone: (419) 755-1011**

or:

**Gorman-Rupp of Canada Limited**  
**70 Burwell Road**  
**St. Thomas, Ontario N5P 3R7**  
**Phone: (519) 631-2870**

## CONTENTS

### SAFETY – SECTION A

### TROUBLESHOOTING – SECTION B

### PUMP MAINTENANCE AND REPAIR – SECTION C

DRAWINGS AND IDENTIFICATION LISTS .....	PAGES C – 4 THRU C-11
PUMP AND SEAL DISASSEMBLY AND REASSEMBLY .....	PAGE C – 12
Priming Chamber Removal and Disassembly .....	PAGE C – 12
Discharge Check Valve Removal and Disassembly .....	PAGE C – 13
Suction Head And Wear Ring Removal .....	PAGE C – 13
Pump Casing Removal .....	PAGE C – 13
Impeller Removal .....	PAGE C – 14
Seal Removal .....	PAGE C – 14
Pedestal Assembly Removal .....	PAGE C – 14
Shaft and Bearing Removal And Disassembly .....	PAGE C – 14
Engine Drive Disassembly .....	PAGE C – 15
Bearing Cleaning And Inspection .....	PAGE C – 16
Engine Drive Reassembly .....	PAGE C – 16

CONTENTS (Cont'd)

Shaft and Bearing Reassembly and Installation . . . . . PAGE C – 17

Pedestal Assembly Installation . . . . . PAGE C – 19

Seal Reassembly And Installation . . . . . PAGE C – 19

Impeller Installation . . . . . PAGE C – 21

Pump Casing Installation . . . . . PAGE C – 21

Suction Head Installation . . . . . PAGE C – 21

Discharge Check Valve Assembly And Installation . . . . . PAGE C – 22

Priming Chamber Assembly And Installation . . . . . PAGE C – 22

LUBRICATION . . . . . PAGE C – 22

    Seal Assembly . . . . . PAGE C – 22

    Bearings . . . . . PAGE C – 22

    Engine . . . . . PAGE C – 23

RECORDING MODEL AND SERIAL NUMBERS

Please record the pump model and serial number in the spaces provided below. Your Gorman-Rupp distributor needs this information when you require parts or service.

Pump Model: \_\_\_\_\_

Serial Number: \_\_\_\_\_

The following are used to alert personnel to procedures which require special attention, to those which could damage equipment, and to those which could be dangerous to personnel:



Immediate hazards which WILL result in severe personal injury or death. These instructions describe the procedure required and the injury which will result from failure to follow the procedure.



Hazards or unsafe practices which COULD result in severe personal injury or death. These instructions describe the procedure required and the injury which could result from failure to follow the procedure.

WARRANTY INFORMATION

The warranty provided with your pump is part of Gorman-Rupp's support program for customers who operate and maintain their equipment as described in this and the other accompanying literature. Please note that should the equipment be abused or modified to change its performance beyond the original factory specifications, the warranty will become void and any claim will be denied.



Hazards or unsafe practices which COULD result in minor personal injury or product or property damage. These instructions describe the requirements and the possible damage which could result from failure to follow the procedure.

NOTE

Instructions to aid in installation, operation, and maintenance or which clarify a procedure.

## SAFETY – SECTION A

The following information applies throughout this manual to Gorman-Rupp Prime Aire® Series pumps.

This manual will alert personnel to known procedures which require special attention, to those which could damage equipment, and to those which could be dangerous to personnel. However, this manual cannot possibly anticipate and provide detailed instructions and precautions for every situation that might occur during maintenance of the unit. Therefore, it is the responsibility of the owner/maintenance personnel to ensure that only safe, established maintenance procedures are used, and that any procedures not addressed in this manual are performed only after establishing that neither personal safety nor pump integrity are compromised by such practices.



Before attempting to install, operate, or service this pump, familiarize yourself with this manual, and with all other literature shipped with the pump. Unfamiliarity with all aspects of pump operation covered in this manual could lead to destruction of equipment, injury, or death to personnel.



Before attempting to open or service the pump:

1. Familiarize yourself with this manual.
2. Shut down the engine or lock out incoming power to the motor and

take precautions to ensure that the pump will remain inoperative.

3. Allow the pump to completely cool if overheated.
4. Check the temperature before opening any covers, plates, or plugs.
5. Close the suction and discharge valves.
6. Vent the pump slowly and cautiously.
7. Drain the pump.



This pump is may be used to handle materials which could cause illness through direct exposure or emitted fumes. Wear adequate protective clothing when working on the pump or piping.



Use lifting and moving equipment in good repair and with adequate capacity to prevent injuries to personnel or damage to equipment. Attach lifting equipment to the lifting device fitted to the pump. If chains or cable are wrapped around the pump to lift it, make certain that they are positioned so as not to damage the pump, and so that the load will be balanced. The bail is intended for use in lifting the pump assembly only. Suction and discharge hoses and piping must be removed from the pump before lifting.



After the pump has been installed, make

certain that the pump and all piping or hose connections are tight, properly supported and secure before operation.



Do not remove plates, covers, gauges, pipe plugs, or fittings from an overheated pump. Vapor pressure within the pump can cause parts being disengaged to be ejected with great force. Allow the pump to cool before servicing.



Overheated pumps can cause severe burns and injuries, and produce explosive fumes. If overheating of the pump occurs:

1. Stop the pump immediately.
2. Ventilate the area.
3. Allow the pump to completely cool.
4. Check the temperature and make sure it is cool before opening any covers, plates, gauges, or plugs.
5. Vent the pump slowly and cautiously.
6. Refer to instructions in the manuals accompanying the pump before restarting the pump.



Do not operate the pump without the guards in place over the rotating parts. Exposed rotating parts can catch clothing, fingers, or tools, causing severe injury to personnel.



Use **only** replacement parts provided or

approved by Gorman-Rupp. Use of non-authorized parts may result in damage to the equipment and/or injury to personnel and **will** invalidate the warranty.



Make sure the pump is level. Lower jack stands and chock the wheels, if so equipped. Use caution when positioning the skid-mounted unit to prevent damage to the fuel tank.



Do not operate an internal combustion engine in an explosive atmosphere. When operating an internal combustion engine in an enclosed area, make sure exhaust fumes are piped to the outside. These fumes contain carbon monoxide, a deadly gas that is colorless, tasteless and odorless.



Fuel used by internal combustion engines presents an extreme explosion and fire hazard. Make certain that all fuel lines are securely connected and free of leaks. Never refuel a hot or running engine. Avoid overfilling the fuel tank. Always use the correct type of fuel.



Never tamper with the governor to gain more power. The governor establishes safe operating limits that should not be exceeded. Refer to the pump Performance Curve for the maximum continuous operating speed.

## TROUBLESHOOTING – SECTION B

Review all SAFETY information in Section A.



**Before attempting to open or service the pump:**

- 1. Familiarize yourself with this manual.**
- 2. Shut down the engine or lock out incoming power to the motor and take precautions to ensure that the pump will remain inoperative.**
- 3. Allow the pump to completely cool if overheated.**
- 4. Check the temperature and make sure pump is cool before opening any covers, plates, or plugs.**
- 5. Close the suction and discharge valves.**
- 6. Vent the pump slowly and cautiously.**
- 7. Drain the pump.**

TROUBLE	POSSIBLE CAUSE	PROBABLE REMEDY
PUMP FAILS TO PRIME	Discharge check valve contaminated, damaged, or unable to seat.  Air compressor head 180° out. Air leak in suction line. Lining of suction hose collapsed. Leaking or worn seal or pump gasket.  Eductor valve leaking. Suction lift or discharge head too high.  Pump speed too slow.  Eductor clogged.  Air compressor damaged or belts broken.  Strainer clogged.	Clean or replace check valve.  Consult factory. Correct leak. Replace suction hose. Check pump vacuum. Replace leaking or worn seal or gasket. Check and replace safety valve. Check piping installation and install bypass line if needed. See <b>INSTALLATION</b> . Check driver output; consult driver operation manual. Check and clean eductor. Check and repair/replace.  Check strainer and clean if necessary.

TROUBLE	POSSIBLE CAUSE	PROBABLE REMEDY
PUMP STOPS OR FAILS TO DELIVER RATED FLOW OR PRESSURE	Eductor clogged. Air leak in suction line. Lining of suction hose collapsed. Leaking or worn seal or pump gasket. Strainer clogged. Discharge check valve clogged. Suction intake not submerged at proper level or sump too small. Impeller or other wearing parts worn or damaged. Impeller clogged. Discharge head too high. Suction lift too high. Pump speed too slow. Belt or flexible coupling broken.	Check and clean eductor. Correct leak. Replace suction hose. Check pump vacuum. Replace leaking or worn seal or gasket. Check strainer and clean if necessary. Check and clean check valve. Check installation and correct submergence as needed. Replace worn or damaged parts. Check that impeller is properly centered and rotates freely. Free impeller of debris. Install bypass line. Measure lift w/vacuum gauge. Reduce lift and/or friction losses in suction line. Check driver output; consult driver operation manual. Check and replace as necessary.
PUMP REQUIRES TOO MUCH POWER	Pump speed too high. Extreme ambient temperature. Discharge head too low. Fuel filter clogged (engine driven units). Liquid solution too thick. Fuel contaminated (engine driven units). Pump or jack shaft bearing(s) frozen.	Check driver output. Reduce pump output. Adjust discharge valve. Check & replace often in extreme operating conditions. Dilute if possible. Check and replace as required. Disassemble, check and replace bearing(s) as required..
PUMP CLOGS FREQUENTLY	Discharge flow too slow. Suction check valve or foot valve clogged or binding. Liquid solution too thick.	Open discharge valve fully to increase flow rate, and run engine at maximum governed speed. Clean valve. Dilute if possible.



TROUBLE	POSSIBLE CAUSE	PROBABLE REMEDY
EXCESSIVE NOISE	Cavitation in pump.  Pumping entrained air.  Pump or drive not securely mounted.  Impeller clogged or damaged.	Reduce suction lift and/or friction losses in suction line. Record vacuum and pressure gauge readings and consult local representative or factory.  Locate and eliminate source of air bubble.  Secure mounting hardware.  Clean out debris; replace damaged parts.
BEARINGS RUN TOO HOT	Bearing temperature is high, but within limits.  Low or incorrect lubricant.  Suction and discharge lines not properly supported.  Drive misaligned.  Excessive tension on drive belt.	Check bearing temperature regularly to monitor any increase.  Check for proper type and level of lubricant.  Check piping installation for proper support.  Align drive properly.  Check belt tension. Adjust as required.

## PUMP MAINTENANCE AND REPAIR – SECTION C

Review all **SAFETY** information in Section A.

Follow the instructions on all tags, label and decals attached to the pump.



**Before attempting to install, operate, or service this pump, familiarize yourself with this manual, and with all other literature shipped with the pump. Unfamiliarity with all aspects of operation or maintenance could lead to destruction of equipment, injury or death to personnel.**

**Use lifting and moving equipment in good repair and with adequate capacity to prevent injuries to personnel or damage to equipment. If slings or chains are used to move the pump or components, make sure that the load is balanced; otherwise serious personal injury or death could result. The bail is intended for use in lifting the pump assembly only. Suction and discharge hoses and piping must be removed from the pump before lifting.**

The maintenance and repair instructions in this manual are keyed to the sectional views and the corresponding parts identification lists on the following pages. Refer to the separate Parts List Manual for replacement parts.

This Maintenance and Repair Manual provides troubleshooting instructions required to properly diagnose operational problems. Maintenance instructions within this manual are limited to the pump hydraulic and drive components only. The pump assembly may be engine or motor driven; therefore, the drive assembly may consist of an engine jack shaft or, for motor drive, V-belt with sheaves or flex-coupling. Maintenance instruc-

tions for engine jack shaft drive components provided by Gorman-Rupp are included in this manual. Alignment of V-belt or flex-type couplings are detailed in the separate Installation and Operation Manual provided with the pump. For maintenance and repair of the engine or air compressor, consult the separate literature provided by the manufacturer(s).

Check **TROUBLESHOOTING**, Section B to determine causes and remedies of pump problems. Disassemble the pump only as far as required.

As described in the **SAFETY** Section, this manual will alert personnel to known procedures which require special attention, to those which could damage equipment, and to those which could be dangerous to personnel. However, this manual cannot possibly anticipate and provide detailed precautions for every situation that might occur during maintenance of the unit. Therefore, it is the responsibility of the owner/maintenance personnel to ensure that **only** safe, established shop procedures are used, and that any procedures not addressed in this manual are performed **only** after establishing that neither personal safety nor pump integrity are compromised by such practices.

Select a suitable location, preferably indoors, to perform required maintenance. All work must be performed by qualified personnel.

### Lifting

Pump unit weights will vary depending on the mounting and drive provided. Check the shipping tag on the unit packaging for the actual weight, and use lifting equipment with appropriate capacity. Drain the pump and remove all customer-installed equipment such as suction and discharge hoses or piping before attempting to lift existing, installed units.

For the approximate weight of your pump, refer to the pump specification data sheet or contact your Gorman-Rupp distributor or the Gorman-Rupp Company.

## SECTION DRAWING

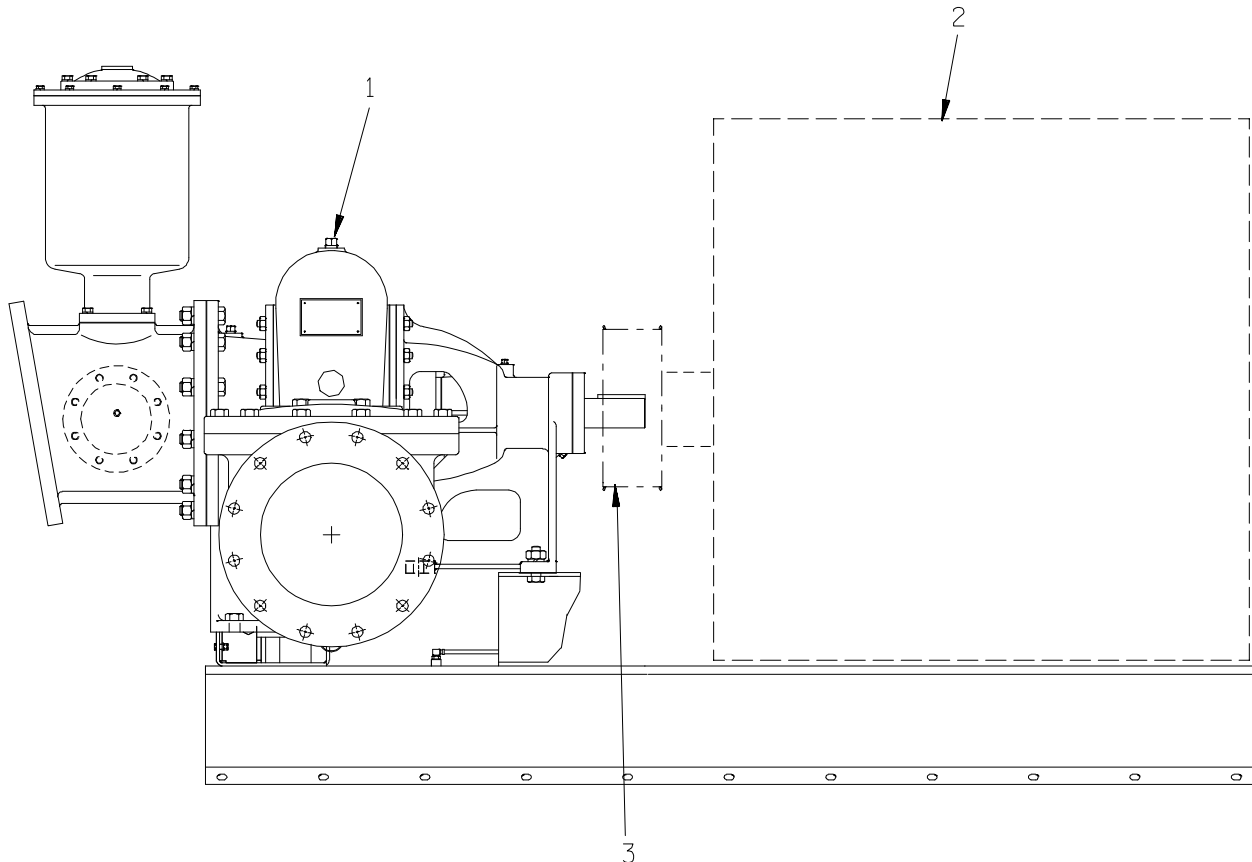

NOTE: The PA12A60-B Pump Assembly may be engine or motor driven; therefore, the drive assembly may consist of an engine jack shaft or, for motor drive, V-belt with sheaves or flex-coupling. Maintenance instructions for engine jack shaft drive components provided by Gorman-Rupp are included in this manual. Alignment of V-belt or flex-type couplings are detailed in the separate Installation and Operation Manual provided with the pump.

Figure C-1. PA12A60-B Pump Subassembly

**PA12A60-B Pump Subassembly  
Part Identification List**

Refer to the separate Parts List Manual for serviceable parts, part numbers and quantities.

ITEM NO.	PART NAME
1	PA12A60-B PUMP MODEL ASSEMBLY
2	DRIVER
3	DRIVE ASSEMBLY

SECTION DRAWING

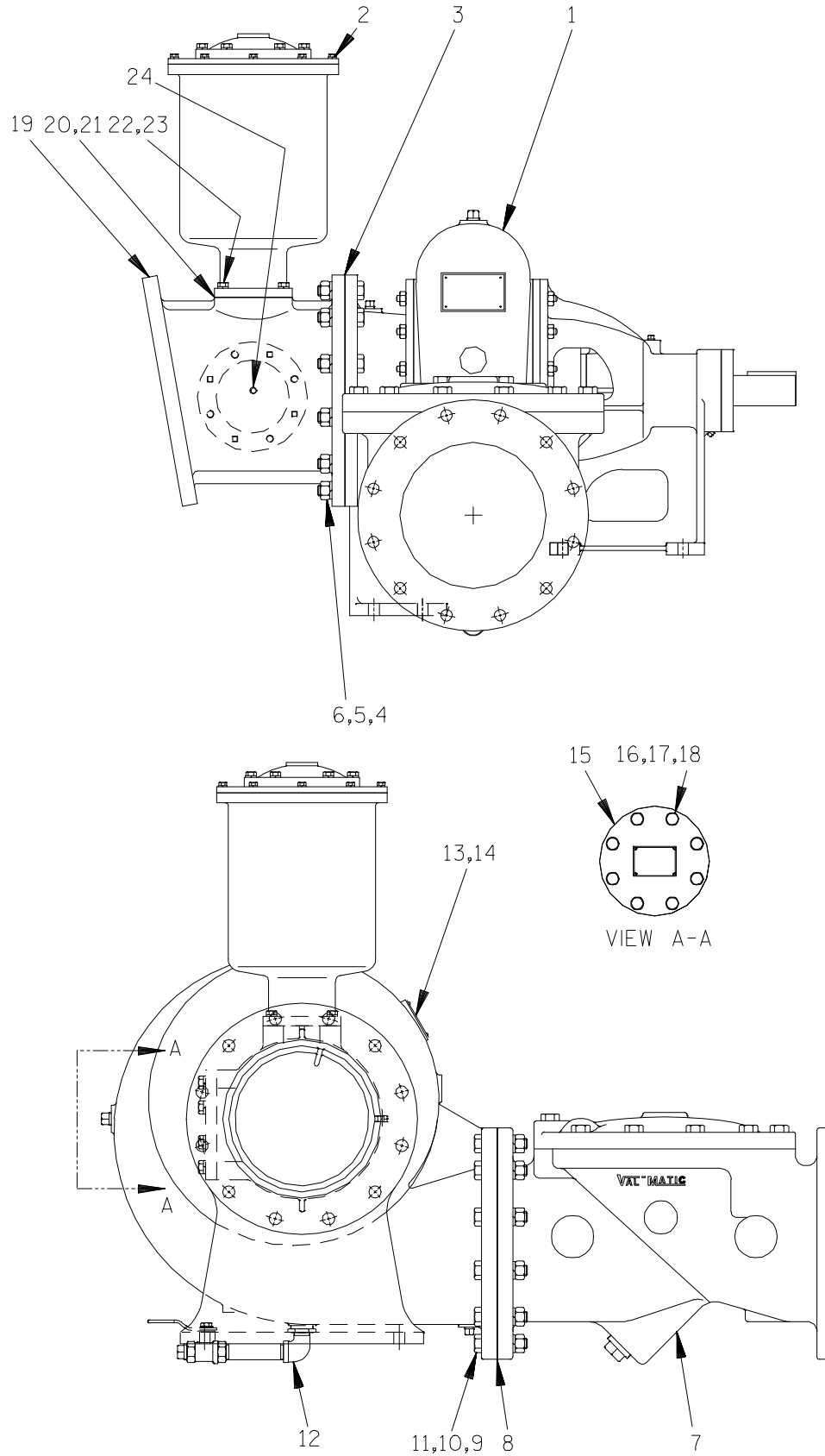

Figure C-2. PA12A60-B Pump Model Assembly

**PA12A60-B Pump Model Assembly  
Part Identification List**

Refer to the separate Parts List Manual for serviceable parts, part numbers and quantities.

ITEM NO.	PART NAME
1	612M60-B PUMP ASSEMBLY
2	PRIMING CHAMBER ASSEMBLY
3	FLANGE GASKET
4	HEX HEAD CAPSCREW
5	LOCK WASHER
6	HEX NUT
7	CHECK VALVE ASSEMBLY -FLAPPER -COVER GASKET
8	FLANGE GASKET
9	HEX HEAD CAPSCREW
10	LOCK WASHER
11	HEX NUT
12	DRAIN VALVE ASSEMBLY
13	NAME PLATE
14	DRIVE SCREW
15	BLIND FLANGE ASSEMBLY
16	HEX HEAD CAPSCREW
17	LOCK WASHER
18	FLANGE GASKET
19	12" SUCTION SPOOL
20	GASKET
21	BAFFLE
22	HEX HEAD CAPSCREW
23	LOCK WASHER
24	PIPE PLUG

SECTION DRAWING

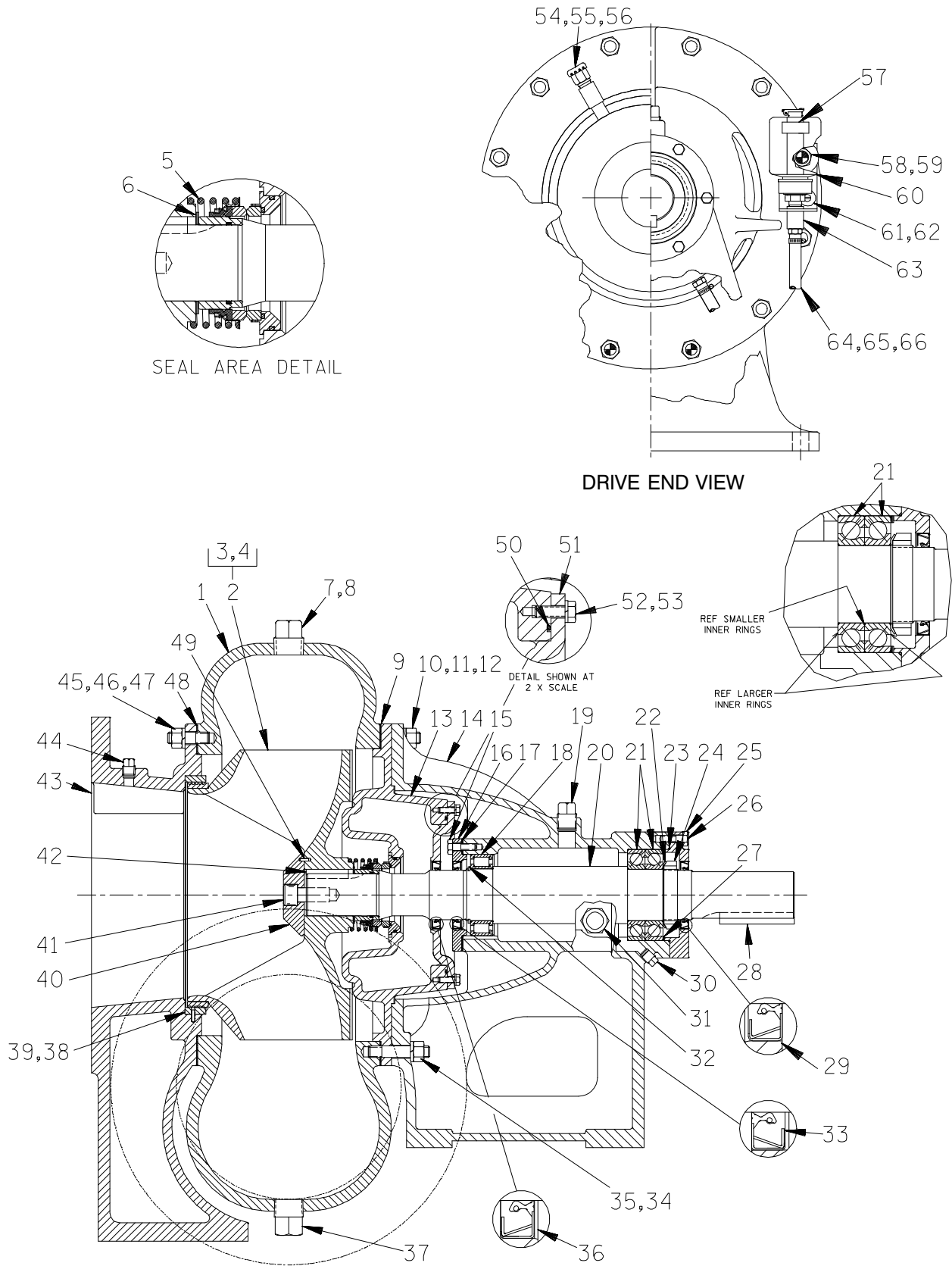

Figure C-3. 612M60-B Pump Assembly

### 612M60—B Pump Assembly Part Identification List

Refer to the separate Parts List Manual for serviceable parts, part numbers and quantities.

ITEM NO.	PART NAME	ITEM NO.	PART NAME
1	PUMP CASING	34	STUD
2	IMPELLER & WEAR RING ASSY	35	HEX NUT
3	—IMPELLER	36	SEAL PLATE OIL SEAL
4	—WEAR RING	37	PIPE PLUG
5	MECHANICAL SEAL	38	SUCTION HEAD WEAR RING
6	SHIM SET	39	SPIRAL PIN
7	PIPE PLUG	40	IMPELLER WASHER
8	PIPE PLUG	41	SOCKET HD CAPSCREW
9	CASING GASKET	42	IMPELLER KEY
10	STUD	43	SUCTION HEAD
11	HEX NUT	44	PIPE PLUG
12	LOCK WASHER	45	STUD
13	SEAL PLATE	46	HEX NUT
14	PEDESTAL	47	LOCK WASHER
15	HEX HD CAPSCREW	48	SUCTION HEAD GASKET
16	BEARING CAP	49	ROLL PIN
17	BEARING CAP GASKET	50	SEAL PLATE COVER O-RING
18	ROLLER BEARING	51	SEAL PLATE COVER
19	VENTED PIPE PLUG	52	HEX HD CAPSCREW
20	IMPELLER SHAFT	53	LOCK WASHER
21	BALL BEARING	54	AIR VENT
22	LOCKING TAB WASHER	55	PIPE NIPPLE
23	BEARING CAP O-RING	56	PIPE COUPLING
24	BEARING LOCKNUT	57	OIL LEVEL DECAL
25	BEARING CAP	58	FLAT WASHER
26	HEX HD CAPSCREW	59	LOCK WASHER
27	SHIM SET	60	BOTTLE OILER
28	SHAFT KEY	61	RD HD MACHINE SCREW
29	OUTBOARD BEARING CAP OIL SEAL	62	LOCK WASHER
30	PIPE PLUG	63	BOTTLE OILER BRACKET ASSY
31	SIGHT GAUGE	64	MALE CONNECTOR
32	RETAINING RING	65	BOTTLE OILER HOSE
33	INBOARD BEARING CAP OIL SEAL	66	HOSE CLAMP



## SECTION DRAWING

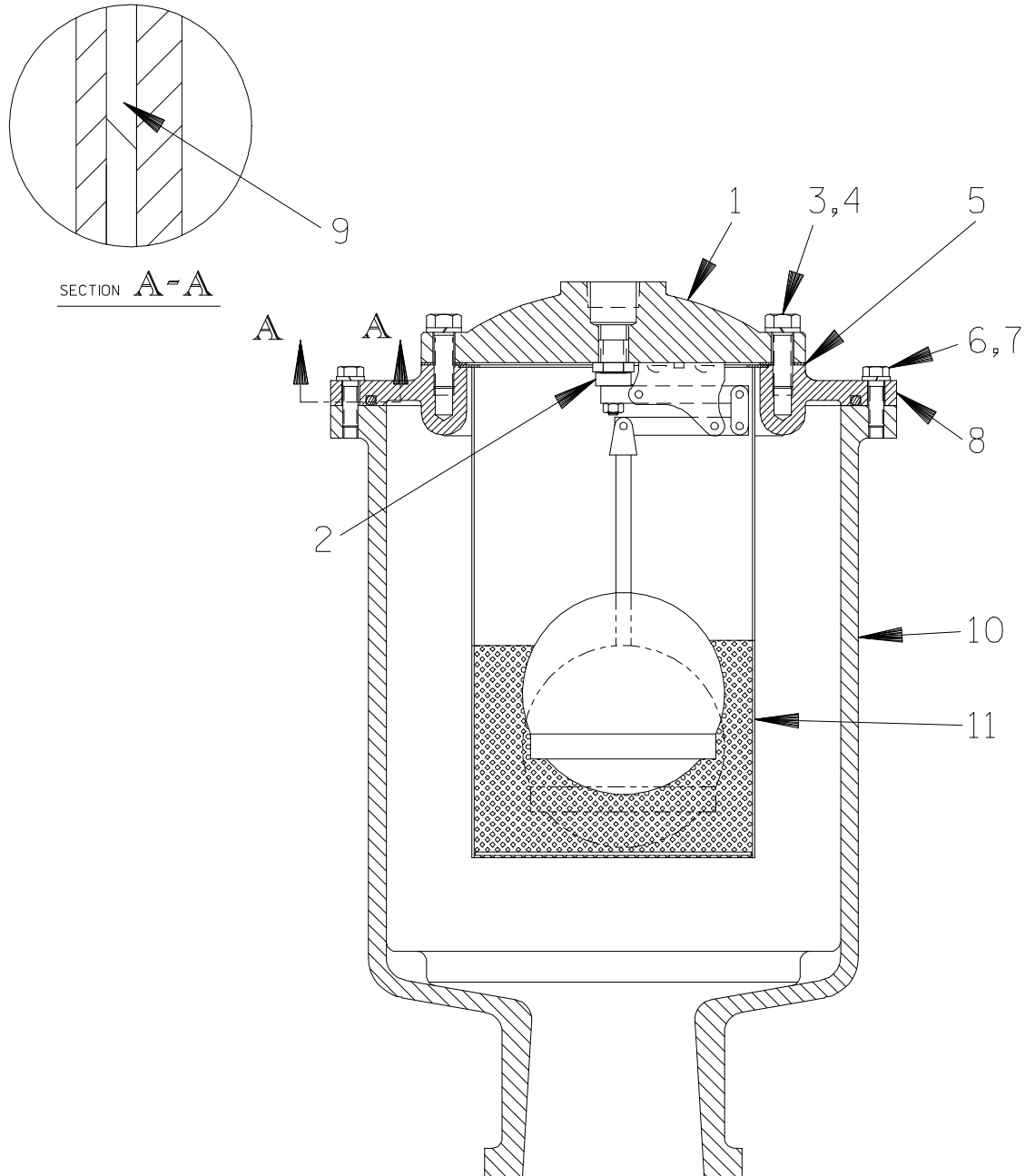

Figure C-4. Priming Chamber Assembly

## Part Identification List

Refer to the separate Parts List Manual for serviceable parts, part numbers and quantities.

ITEM NO.	PART NAME	ITEM NO.	PART NAME
1	PRIMING VALVE	7	LOCK WASHER
2	-ORIFICE BUTTON	8	PRIMING CHAMBER LID
3	HEX HD CAPSCREW	9	LINEAR O-RING
4	LOCK WASHER	10	PRIMING CHAMBER
5	PRIMING VALVE GASKET	11	STRAINER ASSEMBLY
6	HEX HD CAPSCREW		

### Engine Drive Assembly Part Identification List

Refer to the separate Parts List Manual for serviceable parts, part numbers and quantities.

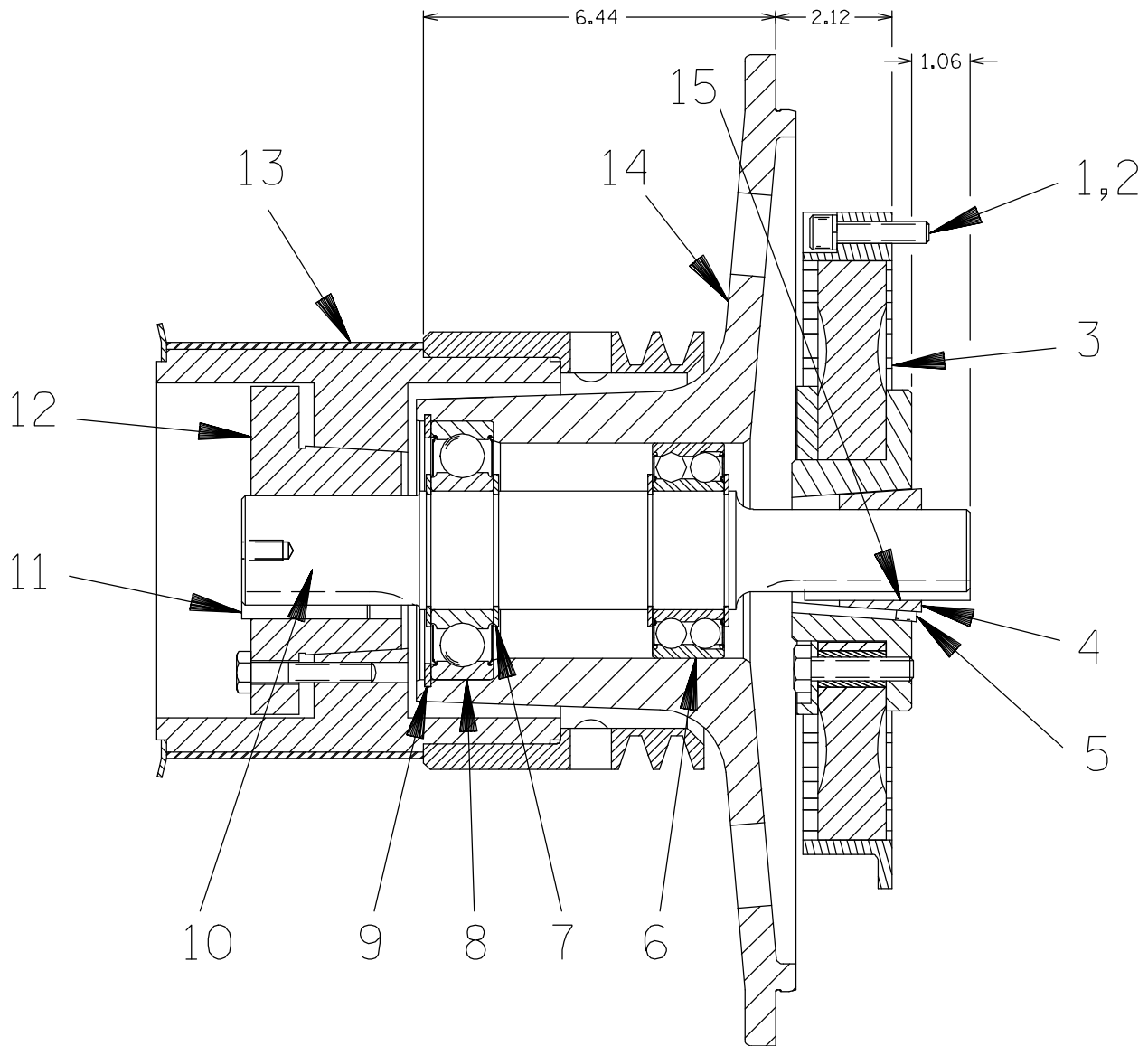

Figure C-5. Engine Drive Assembly

### Engine Drive Assembly Part Identification List

Refer to the separate Parts List Manual for serviceable parts, part numbers and quantities.

ITEM NO.	PART NAME
1	SOCKET HEAD CAPSCREW
2	LOCK WASHER
3	COUPLING ASSEMBLY
4	TAPER LOCK BUSHING
5	-ALLEN HEAD SETSCREW
6	BALL BEARING
7	RETAINING RING
8	BALL BEARING
9	RETAINING RING
10	OUTPUT SHAFT
11	OUTPUT SHAFT KEY (DRIVE END)
12	TAPER LOCK BUSHING
13	DRIVE SPROCKET
14	BEARING HOUSING
15	OUTPUT SHAFT KEY (DRIVEN END)

SECTION DRAWING

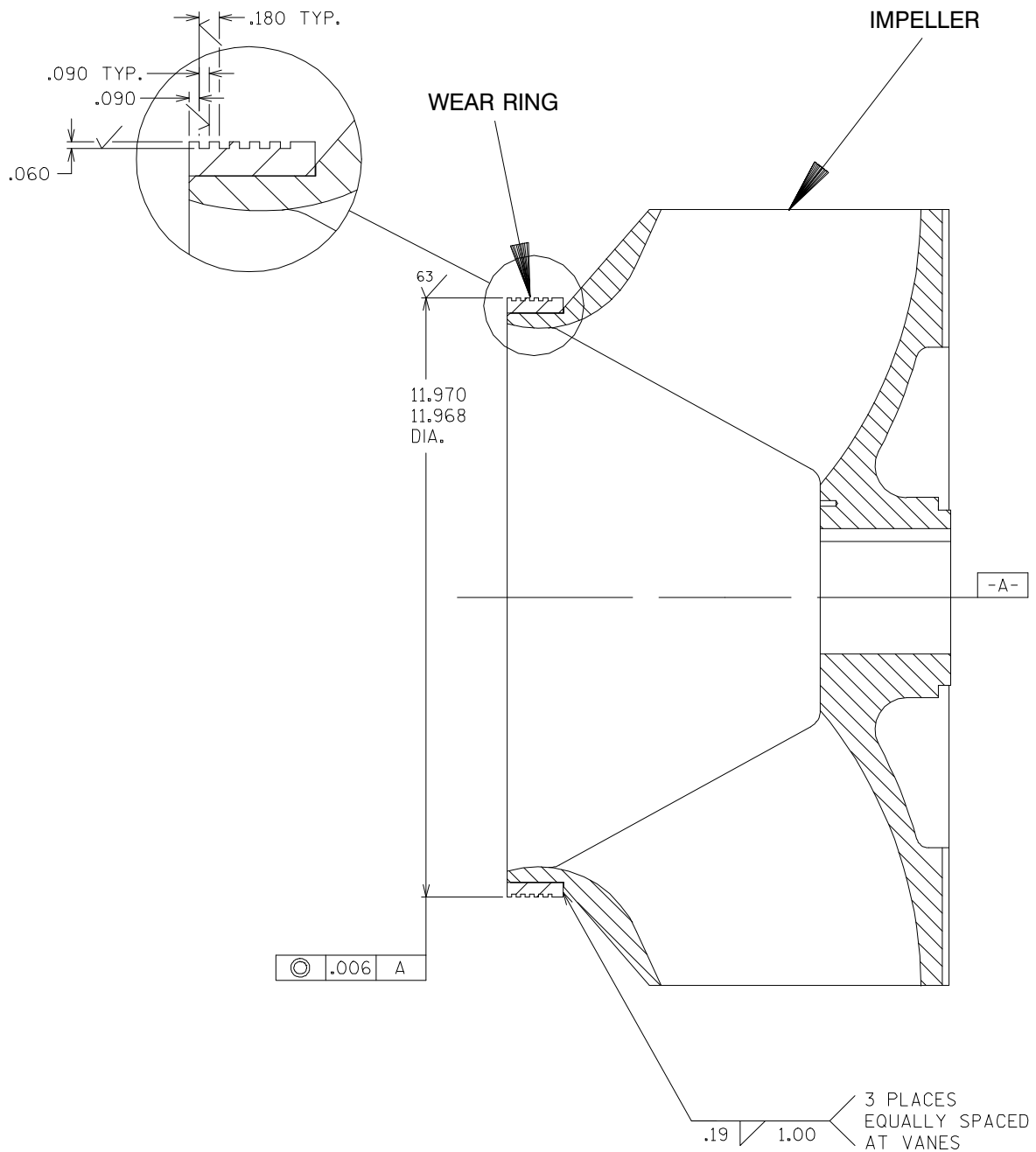

NOTE: UNLESS OTHERWISE SPECIFIED,  
MACHINED SURFACES TO BE 125 RMS.

Figure C-6. Impeller Assembly Machining Tolerances

## PUMP AND SEAL DISASSEMBLY AND REASSEMBLY

Review all SAFETY information in Section A.

Follow the instructions on all tags, label and decals attached to the pump.

This pump requires little service due to its rugged, minimum-maintenance design. However, if it becomes necessary to inspect or replace the wearing parts, follow these instructions which are keyed to the Sectional Views (see Figures C-1 through C-6) and the corresponding Parts Identification Lists. For factory-built engine driven units, engine and air compressor maintenance and repair instructions are covered separately in the specific literature supplied by the manufacturers.

For part numbers and quantities for your specific pump, refer to the separate Parts List manual accompanying the pump.

Many pump service functions may be performed without removing the compressor or pump drive belts. However, the priming chamber assembly (2, Figure C-2) and discharge check valve assembly (7, Figure C-2) must be removed to service pump components. The following instructions assume complete disassembly of the pump is required.

Before attempting to service the pump, shut down the engine and take precautions to ensure that it will remain inoperative. Close all valves in the suction and discharge lines and drain the pump casing by removing the casing drain plug (37, Figure C-3). Clean and reinstall the drain plug.



**Before attempting to open or service the pump:**

1. Familiarize yourself with this manual.
2. Shut down the engine or lock out incoming power to the motor and take precautions to ensure that the pump will remain inoperative.
3. Allow the pump to completely cool if overheated.

4. Check the temperature and make sure it is cool before opening any covers, plates, gauges, or plugs.
5. Close the suction and discharge valves.
6. Vent the pump slowly and cautiously.
7. Drain the pump.



**This pump is designed to handle material which could cause illness through direct exposure or emitted fumes. Wear adequate protective clothing when working on the pump or piping.**



**Use lifting and moving equipment in good repair and with adequate capacity to prevent injuries to personnel or damage to equipment. The hoisting bail on engine-driven units is intended for use in lifting the pump assembly only. Suction and discharge hoses and piping must be removed from the pump before lifting. If chains or cables are used to lift pump components, make certain that they are positioned so as not to damage the pump, and so that the load will be balanced.**



Use **only** replacement parts provided or approved by Gorman-Rupp. Use of non-authorized parts may result in damage to the equipment and/or injury to personnel and **will** invalidate the warranty.

### Priming Chamber Removal and Disassembly (Figure C-2)

Disconnect both the suction piping and the air discharge tubing from the priming valve assembly (2). Support the priming valve assembly using a sling

and a suitable lifting device. Disengage the hardware (22 and 23) and separate the priming valve assembly, gasket (20) and baffle (21) from the pump assembly (1).

#### (Figure C-4)

Remove the hardware (3 and 4) securing the priming valve (1) to the priming lid (8). Carefully lift the valve components from the priming chamber. If the priming valve float is stuck or the strainer (11) is clogged, it can usually be cleaned without further disassembly.

If replacement is required, remove the hardware (6 and 7) securing the priming chamber lid. Replace the O-ring (9) and remove **all** of the old adhesive.

#### Discharge Check Valve Removal and Disassembly

##### (Figure C-2)

Support the discharge check valve assembly (7) using a sling and a suitable lifting device. Remove the hardware (9, 10 and 11) and separate the discharge check valve assembly and gasket (8) from the pump assembly (1).

The flapper and gasket are the only serviceable parts of the check valve. If the flapper requires replacement, remove the hardware securing the cover. Separate the valve cap and remove the flapper and gasket.

#### Suction Head And Wear Ring Removal

##### (Figure C-3)

Remove the hardware securing the suction head (43) to the base. Support the suction head using a suitable hoist and sling. Disengage the hardware (46 and 47) and separate the suction head and wear ring (38) from the pump casing. Remove the suction head gasket (48) and clean the mating surfaces.

Inspect the wear ring for excessive wear or scoring. The wear ring is a press fit into the suction head and is additionally secured with the spiral pins (39). If replacement is required, use a small bit to drill three holes horizontally, 180° apart, through the wear ring between each of the spiral pins. Use a

chisel or other suitable tool to complete the cuts through the wear ring. **Use caution** not to damage the suction head bore. Remove the wear ring sections from the suction head. Pull the spiral pins from the suction head.

If no further disassembly is required, see **Suction Head and Wear Ring Installation**.

#### Pump Casing Removal

##### (Figure C-3)

Support the pump casing using a suitable hoist and sling.



**Use lifting and moving equipment in good repair and with adequate capacity to prevent injuries to personnel or damage to equipment. If slings or chains are used to move the pump or components, make sure that the load is balanced; otherwise serious personal injury or death could result. Suction and discharge hoses and piping must be removed from the pump before lifting.**

#### NOTE

*When removing the pump casing, use a wire to secure the assembled bottle oiler (60) and bracket (63) above the level of the oil in the seal cavity. This will prevent oil from leaking out of the oiler during disassembly.*

If the impeller (2) is to be removed, the impeller screw (41) should be loosened before removing the pump casing. Immobilize the impeller by inserting a wood block through the pump discharge and into the impeller vanes. Remove the impeller screw and washer (40). Remove the wood block from the pump discharge.

Remove the hardware (11, 12, 58 and 59) securing the pump casing and bottle oiler bracket (63) to the pedestal.

Pull the pump casing straight away from the pedestal to prevent binding on the impeller. Remove

the casing gasket (9) and clean the contacting surfaces.

### Impeller Removal

#### (Figure C-3)

Before removing the impeller, loosen the hose clamp (66) and remove the hose (65) from the connector (64). Remove the bottle oiler (60) and bracket assembly and drain the seal cavity. This will prevent oil from escaping when the impeller is removed.

With the impeller screw and washer (40 and 41) removed as described in **Pump Casing Removal**, insert a pair of wedges 180° apart between the impeller and the seal plate. Tap the wedges alternately to force the impeller off the shaft. Retain the impeller key (42).

Inspect the wear ring (4) for excessive wear or scoring.



Proper wear ring replacement requires machining and dynamic balancing the impeller assembly after the wear ring is welded to the impeller. Failure to properly install the wear ring and machine and balance the impeller assembly can result in premature shaft, seal or bearing failure, or other damage to the pump.

To replace the wear ring, grind off the three weld spots securing the wear ring to the impeller. **Use caution** not to damage the impeller. Pry or carefully grind the wear ring off the impeller.

### Seal Removal

#### (Figures C-3 and C-9)

This pump is designed with two seals; a primary mechanical seal (5) located directly behind the impeller and a secondary oil seal (36) located in the seal plate cover (51). If the liquid being pumped leaks past the oil seal, both seals should be replaced immediately.

Remove the impeller shims (6). Tie and tag the shims for ease of reassembly. Remove the seal spring. Slide the rotating portion of the seal (consisting of the shaft sleeve and O-ring, bellows and retainer, and rotating element) off the shaft as a unit.

Remove the rotating element. Apply oil to the sleeve and work it up under the rubber bellows. Slide the bellows and retainer off the sleeve. Remove the sleeve O-ring.

Remove the air vent and piping (54, 55 and 56) and slide the seal plate and remaining seal components off the shaft. Disengage the hardware (52 and 53) and separate the seal plate cover and O-ring (51) from the seal plate.

Use a suitably sized dowel to press the stationary portion of the seal out of the seal plate. Press the oil seal out of the seal plate cover.

If no further disassembly is required, refer to **Seal Installation**.

### Pedestal Assembly Removal

#### (Figure C-3)

Disassembly of the pedestal requires separation of the pump and driver. If the pump is flex-coupled to a variable speed motor loosen, then separate, the halves of the coupling before removal of the pump.

If the pump is V-belt driven, loosen and remove the pump drive belt(s) and sheave.

If the pump is engine driven, loosen the engine and air compressor tensioners and use pry bars to move the engine assembly and air compressor enough to remove the compressor and pump drive belts.

Remove the hardware securing the pedestal to the base. Use a suitable hoist and sling to remove the pedestal assembly.

### Shaft and Bearing Removal and Disassembly

Remove any remaining drive components from the drive end of the shaft. If the pump is engine driven, the sprocket and hub are supplied from the factory and may be removed as follows.

**(Figure C-7)**

Remove the screws securing the sprocket to the hub, then reinstall the screws in the tapped holes in the sprocket. Tighten the screws in an alternating sequence to press against the hub shoulder and “jack” the sprocket off the hub.

With the sprocket removed, the hub can be pulled or pried off the shaft. Remove the shaft key.

**(Figure C-3)**

When the pump is properly operated and maintained, the pedestal should not require disassembly. Disassemble the shaft and bearings **only** when there is evidence of wear or damage.



Shaft and bearing disassembly in the field is not recommended. These operations should be performed only in a properly equipped shop by qualified personnel.

Before disassembling the pedestal, remove the pedestal drain plug (30) and drain the oil from the pedestal. Clean and reinstall the pipe plug.

Disengage the capscrews (26) and and remove the outboard bearing cap (25), O-ring (23) and oil seal (29). Remove the bearing shims (27). Press the oil seal from the bearing cap.

Straighten the tab on the washer (22) securing the bearing lock nut (24). Use a spanner wrench to remove the lock nut. Remove the tab washer.

Disengage the capscrews (15) and remove the inboard bearing cap (16) and oil seal (33). Remove the bearing cap gasket (17) and clean the mating surfaces. Press the oil seal from the bearing cap.

Place a block of wood against the impeller end of the shaft (20) and tap the shaft and assembled bearings (18 and 21) out of the pedestal.

After removing the shaft and bearings, clean and inspect the bearings **in place** as described in **Bearing Cleaning And Inspection**.

The bearing tolerances provide a tight press fit onto the shaft and a snug slip fit into the pedestal. Replace the bearings, shaft, or pedestal if the proper bearing fit is not achieved.

If bearing replacement is required, remove the retaining ring (32) and use a bearing puller to remove the inboard and outboard bearings from the shaft.

**Engine Drive Disassembly****(Figure C-5)**

Factory-built engine driven units are equipped with a jackshaft type drive assembly as shown in Figure C-5.

To remove the sprocket (13), remove the capscrews securing the taperlock bushing (12) to the sprocket. Reinstall the capscrews in the tapped holes in the bushing, and use a suitable puller to pull the bushing and sprocket off the output shaft (10). Retain the key (11).

Further disassembly requires separating the remaining drive components from the engine. Remove the hardware (not shown, supplied with the engine) securing the bearing housing (14) to the engine. Pull the shaft and bearing housing straight away from the engine. The rubber drive element of the coupling (3) will separate from the drive ring secured to the engine flywheel with the hardware (1 and 2). Disengage the hardware to remove the drive ring from the flywheel.

To remove the flexible portion of the coupling from the output shaft, unscrew the two allen head setscrews (5) from the bushing (4). Screw one of the setscrews into the hole on the circumference of the bushing to separate the coupling and bushing. When the parts separate, remove the bushing, and slide the coupling off the shaft. Remove the key (15).

When properly operated and maintained, the output shaft and bearings should not require disassembly. Disassemble the shaft and bearings **only** when there is evidence of wear or damage.



Shaft and bearing disassembly in the field



is not recommended. These operations should be performed only in a properly equipped shop by qualified personnel.

To remove the shaft and bearings (6 and 8), use snap ring pliers to remove the retaining ring (9). Use a wood block to tap the shaft and bearings out of the bearing housing from the driven end.

After removing the shaft and bearings, clean and inspect the bearings **in place** as described in **Bearing Cleaning And Inspection**.



To prevent damage during removal from the shaft, it is recommended that bearings be cleaned and inspected **in place**. It is **strongly** recommended that the bearings be replaced **any** time the shaft and bearings are removed.

The bearing tolerances provide a tight press fit onto the shaft and a snug slip fit into the bearing housing. Replace the bearings, shaft, or bearing housing if the proper bearing fit is not achieved.

If bearing replacement is required, remove the outboard retaining rings (7) and use a bearing puller to remove the inboard (6) and outboard (8) bearings from the shaft.

It is not necessary to remove the inboard bearing retaining rings unless replacement is required. Use snap ring pliers to remove the retaining rings as required.

### Bearing Cleaning And Inspection

Clean the bearing housing, shaft and all component parts (except the bearings) with a soft cloth soaked in cleaning solvent. Inspect the parts for wear or damage and replace as necessary.



**Most cleaning solvents are toxic and flammable. Use them only in a well ventilated area free from excessive heat,**

**sparks, and flame. Read and follow all precautions printed on solvent containers.**

Clean the bearings thoroughly in **fresh** cleaning solvent. Dry the bearings with filtered compressed air and coat with light oil.

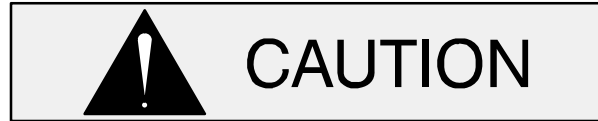

Bearings must be kept free of all dirt and foreign material. Failure to do so will greatly shorten bearing life. **Do not** spin dry bearings. This may scratch the balls or races and cause premature bearing failure.

Rotate the bearings by hand to check for roughness or binding. Inspect the bearing balls (or rollers) on open-type bearings. If rotation is rough or the balls or rollers on open bearings appear discolored, replace the bearings.

### Engine Drive Reassembly

#### (Figure C-5)

Inspect the output shaft for distortion, nicks, scratches, damaged keyways or galling on the bearing seating surfaces. Dress small nicks and burrs with a fine file or emery cloth. Replace the shaft if defective.

If removed, install the inboard bearing retaining rings (7) on the output shaft (10).



To prevent damage during removal from the shaft, it is recommended that bearings be cleaned and inspected **in place**. It is **strongly** recommended that the bearings be replaced **any** time the shaft and bearings are removed.

The bearings may be heated to ease installation. An induction heater, hot oil bath, electric oven, or hot plate may be used to heat the bearings. Bearings should **never** be heated with a direct flame or directly on a hot plate.

**NOTE**

If a hot oil bath is used to heat the bearings, both the oil and the container must be **absolutely** clean. If the oil has been previously used, it must be **thoroughly** filtered.

Heat the bearings to a uniform temperature **no higher than 250°F (120°C)**, and slide the bearings onto the shaft, one at a time, until they are fully seated. This should be done quickly, in one continuous motion, to prevent the bearings from cooling and sticking on the shaft.

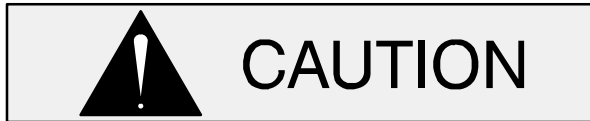

Use caution when handling hot bearings to prevent burns.

After the bearings have been installed and allowed to cool, check to ensure that they have not moved in shrinking. If movement has occurred, use a suitably sized sleeve and a press to reposition the bearings.

If heating the bearings is not practical, use a suitably sized sleeve and an arbor (or hydraulic) press to install the bearings on the shaft.

Slide the shaft and assembled bearings into the bearing housing until the outboard bearing is fully seated against the bearing housing.

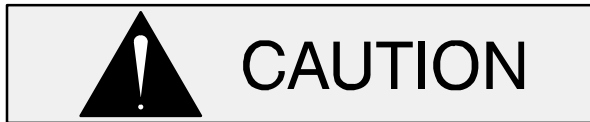

When installing the shaft and bearings into the bearing bore, push against the outer race. **Never** hit the balls or ball cage.

Secure the shaft and bearings in the bearing housing with the bearing retaining ring (9).

Install the key (15) in the output shaft keyway. Position the flexible portion of the coupling assembly (3) on the shaft as shown in Figure C-5.

**NOTE**

The flexible portion of the coupling must be properly positioned on the shaft. The heads of the capscrews in the center of the coupling **must be posi-**

**tioned toward the pump end of the shaft.**

Align the keyway in the bushing (4) with the shaft key, and slide the bushing onto the shaft. Rotate the flexible portion of the coupling until the tapped holes for the two setscrews align with those in the bushing and install the setscrews. Position the coupling to the dimension shown in Figure C-5.



Make certain that the flexible portion of the coupling is mounted as shown in Figure C-5. **This is critical.** If the coupling is not properly positioned on the shaft, the coupling parts may not fully engage, or a pre-load condition can cause premature bearing failure.

With the flexible portion of the coupling and the bushing properly positioned on the shaft, tighten the two setscrews in an alternating sequence until the bushing and coupling are fully secured. Torque the setscrews to 14.6 ft. lbs. (175 in. lbs. or 2 m. kg.) maximum.

If the complete coupling assembly is being replaced, apply 'Loctite Retaining Compound No. 242' or equivalent compound to the threads of the hardware (1 and 2), and secure the outer ring of the coupling to the engine flywheel by torquing the hardware to 45 ft. lbs. (540 in. lbs. or 6,2 m. kg.).

Position the assembled coupling, bearing housing, shaft and bearings so the flexible portion of the coupling seats inside the drive ring attached to the engine flywheel.

**NOTE**

To ease installation, **lightly** lubricate the rubber portion of the coupling with a **non-petroleum based lubricant** such as vegetable oil or glycerin, or a silicon-based lubricant such as "WD40" or equivalent. **Do not** use petroleum-based lubricants, or any other substance which may soften or otherwise damage the rubber.

Position the key (11) in the shaft keyway. Position the drive sprocket over the shaft and bearing housing. Align the keyway in the taperlock bushing (12)

with the shaft key and slide the bushing onto the shaft. Align the holes in the bushing with those in the sprocket, and install the bushing capscrews.

Position the sprocket on the shaft to the dimension shown in Figure C-5 and tighten the bushing capscrews in an alternating sequence until the bushing and coupling are fully secured. Torque the setscrews to 60 ft. lbs. (720 in. lbs. or 8.3 m. kg.).

### Shaft and Bearing Reassembly and Installation

#### (Figure C-3)

Inspect the shaft for distortion, nicks or scratches, or damaged keyways. Dress small nicks and burrs with a fine file or emery cloth. Replace the shaft if defective.



To prevent damage during removal from the shaft, it is recommended that bearings be cleaned and inspected **in place**. It is **strongly** recommended that the bearings be replaced **any** time the shaft and bearings are removed.

The bearings may be heated to ease installation. An induction heater, hot oil bath, electric oven, or hot plate may be used to heat the bearings. Bearings should **never** be heated with a direct flame or directly on a hot plate.



Use caution when handling hot bearings to prevent burns.

#### NOTE

*If a hot oil bath is used to heat the bearings, both the oil and the container must be **absolutely** clean. If the oil has been previously used, it must be **thoroughly** filtered.*

Heat the bearings to a uniform temperature **no higher than** 250°F (120°C). Slide the roller bear-

ing (18) onto the shaft until fully seated against the shaft shoulder. This should be done quickly, in one continuous motion, to prevent the bearing from cooling and sticking on the shaft.

Secure the roller bearing on the shaft with the bearing retaining ring (32).

After the bearing has been installed and allowed to cool, check to ensure that it has not moved away from the shaft shoulder in shrinking. If movement has occurred, use a suitably sized sleeve and a press to reposition the bearing against the shaft shoulder.

Slide the heated outboard bearings (21) onto the shaft, one at a time, with the larger inner races of each bearing positioned away from each other as shown in Figure C-3.

If heating the bearings is not practical, use a suitably sized sleeve, and an arbor (or hydraulic) press to install the bearings on the shaft.

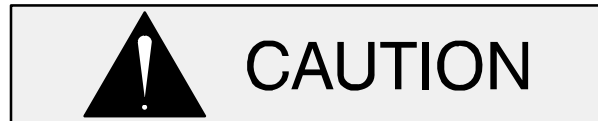

When installing the bearings onto the shaft, **never** press or hit against the outer race, balls, or ball cage. Press **only** on the inner race.

Secure the assembled shaft and bearings by clamping on the surface between the bearings. Use caution not to scratch or mar the part number etched into the shaft in this area. Install the tab washer (22) and bearing lock nut (24). Torque the lock nut to 150 ft. lbs. (1800 in. lbs. or 20,7 m. kg.). Locate the tab on the lockwasher that aligns with a slot in the lock nut, and bend the tab over into the slot.

Slide the shaft and assembled bearings into the pedestal until the shoulder on the inboard ball bearing (21) seats against the pedestal.



When installing the shaft and bearings into the bearing bore, push against the outer race. **Never** hit the balls or ball cage.

Press the oil seal (29) into the bearing cap (16) with the lip positioned as shown in Figure C-3. Lubricate and install a new bearing cap O-ring (23) and secure the bearing cap with the capscrews (26). Use caution not to cut or roll the lip of the oil seal (29) when installing the bearing cap.

Press the oil seal (33) into the bearing cap (16) with the lip positioned as shown in Figure C-3. Replace the bearing cap gasket (17). Install the same thickness of bearing adjusting shims (27) as previously removed and secure the bearing cap with the capscrews (15). Use caution not to cut or roll the lip of the oil seal when installing the bearing cap.

### NOTE

Shaft endplay should be between .001 and .004 inch (0,02 and 0,10 mm). Add or remove adjusting shims to establish the correct endplay.

Lubricate the pedestal as indicated in **LUBRICATION**.

Install any remaining drive components to the drive end of the shaft. If the pump is engine driven, install the sprocket and hub supplied from the factory as follows.

### (Figure C-7)

Install the key (28, Figure C-3) in the shaft keyway. Align the keyway in the hub with the shaft key, and slide the hub onto the shaft with the shoulder positioned toward the pedestal.

Slide the sprocket over the hub, align the mounting screw holes and install the mounting screws.

Position the hub and sprocket to the dimensions shown in Figure C-7 and torque the mounting capscrews to 75 ft. lbs. (900 in. lbs. or 10.4 m. kg.)

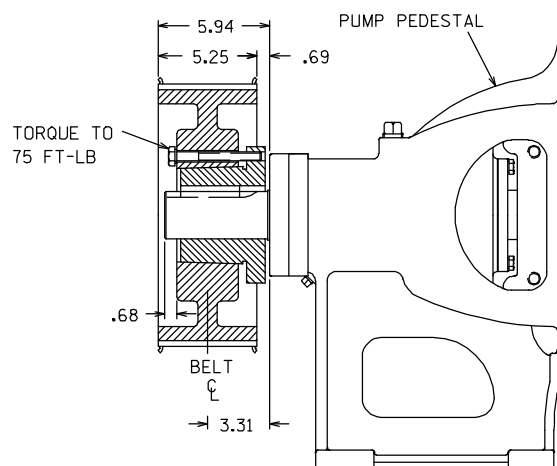

Figure C-7. Hub and Sprocket Installation



Make certain that the hub and sprocket are mounted as shown in Figure C-7. **This is critical.** If the sprocket is not properly positioned on the shaft, the pump drive belt will not be properly aligned, which can cause premature belt or bearing failure.

### Pedestal Assembly Installation

If the pump was flex-coupled to a variable speed motor, install the coupling half on the drive end of the impeller shaft.

If the pump was V-belt driven, install the sheave on the drive end of the impeller shaft.

Use a suitable hoist and sling to position the pedestal assembly on the base. Secure the pedestal to the base using the previously removed hardware.

For a flex-coupled drive, reconnect and align the coupling halves as described in the separate **Installation And Operation Manual**. For a V-belt drive, align the belt(s) and use the motor tensioners to tighten the belts as described in the separate **Installation And Operation Manual**.

If the pump is engine driven, install the compressor and pump drive belts after assembling the remaining pump components. See Figure C-8 and use the compressor tensioners to tighten the compressor belts as indicated in the manual accompanying the air compressor.

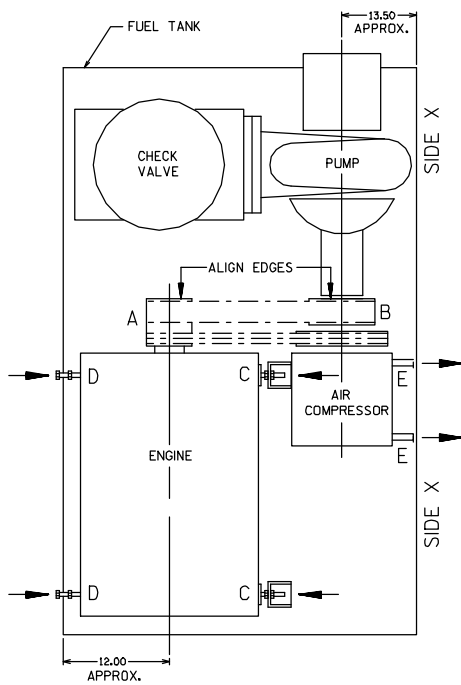

**Figure C-8. Belt Adjustment**

To adjust the drive belt tension, find the center of the belt span between the pump and engine. Use a belt deflection gauge to measure deflection **across the width of the belt** at this point. See Figure C-8 and use the engine tensioners to adjust belt tension to 3/8 inch (9,5 mm) of deflection at 30 lbs. (13,6 kg.) of pressure. **Do not** over-tighten the drive belt.



The inner edge of the pump pulley must be aligned with the outer edge of the drive pulley as shown in Figure C-8 in order to prevent side wear of the cog belt.

**Do not** over-tighten the drive belt. Over-tightening will cause premature belt and/or bearing failure.

### Seal Reassembly and Installation

(Figures C-3 and C-9)

Clean the bore of the seal plate (13), the seal plate cover (51) and the shaft (28) with a cloth soaked in fresh cleaning solvent.



**Most cleaning solvents are toxic and flammable. Use them only in a well ventilated area free from excessive heat, sparks, and flame. Read and follow all precautions printed on solvent containers.**

Lay the seal plate cover on a flat surface with the inner side facing up. Press the oil seal (33) into the seal plate cover with the lip positioned as shown in Figure C-3.

Install a new O-ring (50) in the groove in the seal plate (13) and secure the seal plate cover to the seal plate with the hardware (52 and 53).

Since the mechanical seal is the primary seal in the pump, special consideration should be given to ensure proper installation.

The seal is not normally reused because wear patterns on the finished faces cannot be realigned during reassembly. This could result in premature failure. If necessary to reuse an old seal in an emergency, **carefully** wash all metallic parts in fresh cleaning solvent and allow to dry thoroughly.

Handle the seal parts with extreme care to prevent damage. Be careful not to contaminate precision finished faces; even fingerprints on the faces can shorten seal life. If necessary, clean the faces with a non-oil based solvent and a clean, lint-free tissue. Wipe **lightly** in a concentric pattern to avoid scratching the faces.

Inspect the seal components for wear, scoring, grooves, and other damage that might cause leakage. Clean and polish the shaft sleeve, or replace it if there are nicks or cuts on either end. If any components are worn, replace the complete seal; **never mix old and new seal parts.**

If a replacement seal is being used, remove it from the container and inspect the precision finished faces to ensure that they are free of any foreign matter.

To ease installation of the seal, lubricate the bellows and stationary seat O-rings with water or a very **small** amount of oil, and apply a drop of light

lubricating oil on the finished faces. Assemble the seal as follows, (see Figure C-9).

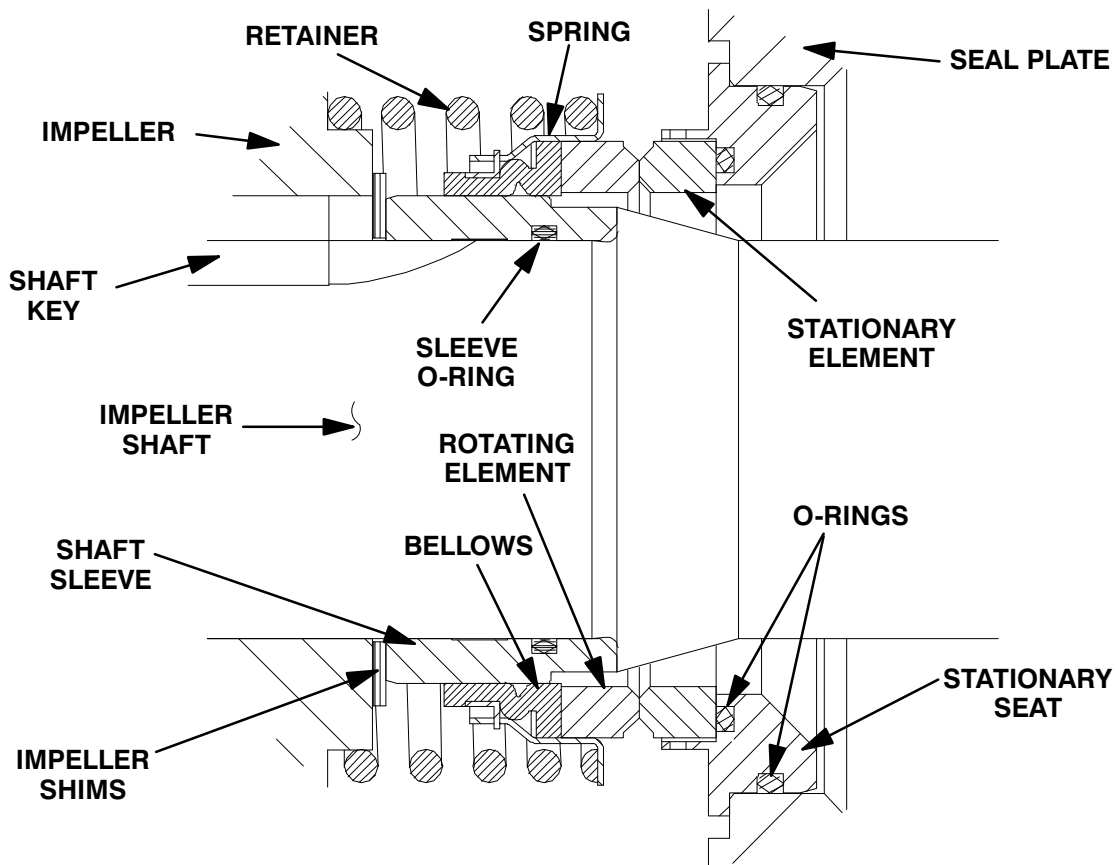
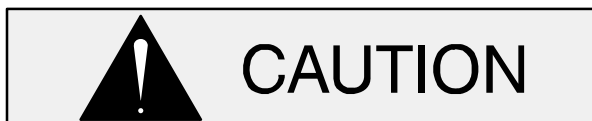

Figure C-9. Seal Assembly



The standard seal is not designed for operation at temperatures above 160°F (71°C). Do not use at higher operating temperatures.

Lubricate the stationary seat O-rings with water or light oil, and install them in the stationary seat. Install the stationary seal element in the stationary seat. Position the seal plate on a flat surface with the impeller side up and press this stationary sub-assembly into the front of the seal plate until it seats squarely against the bore shoulder.

Position the assembled seal plate and stationary seat over the shaft, and temporarily secure it to the pedestal with three 1/2-inch x 2-inch long capscrews and nuts (not supplied). **Be careful** not to

damage the stationary element or roll or cut the lip of the oil seal (36) on the shaft keyway.

Lubricate the seal sleeve O-ring with a **small** amount of light oil and install it in the groove in the I.D. of the sleeve.

Lubricate the seal sleeve with a **small** amount of light oil and slide the rotating subassembly (consisting of rotating element, bellows and retainer), onto the sleeve until the rotating element is **just flush** with the **turned** end of the sleeve.

Slide the sleeve and subassembled seal onto the shaft until the seal faces contact and the sleeve seats against the shaft shoulder.

Install the seal spring. Lubricate the seal as indicated in **LUBRICATION** after the impeller, remaining pump components, bottle oiler and piping are installed.

## Impeller Installation

(Figure C-3)



Proper wear ring replacement requires machining and dynamic balancing the impeller assembly after the wear ring is welded to the impeller. Failure to properly install the wear ring and machine and balance the impeller assembly can result in premature shaft, seal or bearing failure, or other damage to the pump.

Inspect the impeller, and replace it if cracked or badly worn. If the wear ring (4) was removed, chill the impeller by refrigeration and use an induction heater or oven to heat the new wear ring. Slide the wear ring onto the impeller until fully seated against the shoulder and allow it to cool.

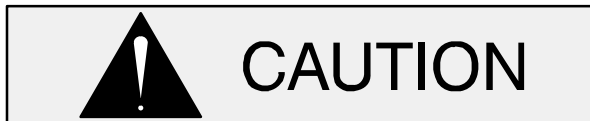

The wear ring **must** seat squarely on the impeller; otherwise binding and/or excessive wear will occur. Use caution when handling hot parts to prevent burns.

Spot weld the wear ring to the impeller at three places, equally spaced at the vanes. After welding, machine the wear ring as shown in Figure C-6.

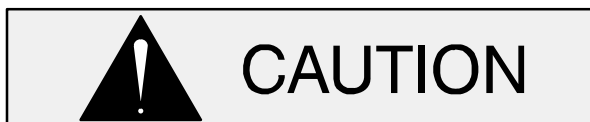

The impeller assembly must be machined and balanced as shown in Figure C-6. Otherwise, premature shaft, seal or bearing failure, or other damage to the pump may occur.

After machining, dynamically balance the impeller assembly per plane 1.05 oz./in. (11.7 g/cm).

Install the same thickness of impeller adjusting shims (6) as previously removed. Install the shaft key (42) and press the impeller assembly onto the shaft until fully seated.

A clearance of approximately .015 inch (0,38 mm) between the impeller and the seal plate is recommended for maximum pump efficiency. Measure this clearance, and add or remove impeller adjusting shims as required.

After the impeller clearance has been set, align the pin in the impeller washer (40) with the hole in the impeller and install the washer. Apply “Never-Seez” or equivalent compound on the threads of the impeller capscrew (41). Immobilize the shaft and secure the the impeller by torquing the capscrew to 225 ft. lbs. (2700 in. lbs. or 31 m. kg.).

## Pump Casing Installation

(Figure C-3)

Install the casing gasket (9) over the pump casing studs (10). Remove the hardware temporarily securing the seal plate to the pedestal. Use a suitable hoist and sling to position the volute over the impeller and slide the studs through the seal plate and pedestal mounting holes.

Install the bottle oiler bracket (63) over the volute studs. Secure the bracket and volute casing with the hardware (11, 12, 35, 58 and 59). Reconnect the hose (65) to the connector (64) in the seal plate and secure it with the hose clamp (66).

Reinstall the air vent and piping (54, 55 and 56) in the seal plate.

## Suction Head Installation

(Figure C-3)

If the wear ring (38) was removed, chill the wear ring by refrigeration and heat the suction head. Slide the wear ring into the suction head until fully seated and allow it to cool.

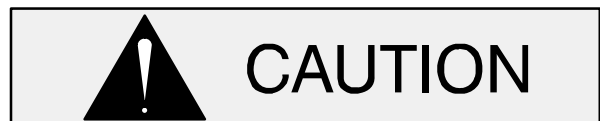

The wear ring **must** seat squarely in the suction head; otherwise binding and/or excessive wear will occur. Use caution when handling hot parts to prevent burns.

The wear ring is secured to the suction head with the spiral pins (39). Drill three evenly spaced 3/16-inch diameter x 3/4-inch deep holes through

the wear ring and into the suction head. Tap the spiral pins into the holes until fully seated.

Install the suction head gasket (48). Position the suction head over the studs (45) and secure it with the hardware (46 and 47).

Turn the impeller shaft by hand and check for any scraping or binding and correct it before putting the pump into service.

### Discharge Check Valve Assembly and Installation

#### (Figure C-2)

The flapper and gasket are the only serviceable parts of the check valve. If the flapper requires replacement, remove the hardware securing the cover and gasket. Separate the valve cap and replace the flapper.

Install the valve cap gasket and secure the cap with the previously removed hardware.

Support the discharge check valve assembly (7) using a sling and a suitable lifting device. Secure the discharge check valve assembly and gasket (8) to the pump assembly (1) using the hardware (9, 10 and 11)

### Priming Chamber Assembly And Installation

#### (Figure C-4)

If the priming chamber lid (8) was removed, install the linear O-ring (9) using “3M Scotchgrip No.847” or equivalent compound in the groove. Secure the priming chamber lid and gasket with the hardware (6 and 7).

#### NOTE

*Cut the lap joint where the two ends of the gasket strip meet at a 45° angle.*

Clean and inspect the components of the priming valve (1). Inspect the linkage and ensure the orifice button (2) squarely engages the valve seat. Replace the button if required.

Adjust the seating if necessary by loosening the locknut and screwing the orifice button into or out

of the linkage. Tighten the locknut when adjustment is complete.

Install the priming valve gasket (5). Install the strainer (11).

Lower the float into the priming chamber (10) and secure the valve with the previously removed hardware (3 and 4).

#### (Figure C-2)

Install the baffle (21) and gasket (20) and use a sling and suitable lifting device to position the priming chamber assembly against the pump suction spool (19). Secure the priming chamber assembly with the hardware (22 and 23).

Reconnect the air discharge tubing to the priming chamber assembly.

## LUBRICATION

### Seal Assembly

#### (Figure C-3)

Fill the bottle oiler (60) and seal cavity with approximately 85 ounces (2,5 liter) SAE No. 30 non-detergent oil. Check the oil level regularly and refill as required.

### Bearings

#### (Figure C-3)

The pedestal was fully lubricated when shipped from the factory. Check the oil level regularly through the sight gauges (31) and maintain it at the midpoint of the gauges. When lubrication is required, remove the vented plug (19) and add SAE No. 30 non-detergent oil through the opening. Clean and reinstall the vented plug. **Do not** over-lubricate. Over-lubrication can cause the bearings to over-heat, resulting in premature bearing failure.

#### NOTE

*The white reflector in the sight gauge must be positioned horizontally to provide proper drainage.*

Under normal conditions, drain the bearing housing once each year and refill with approximately 14 ounces (0,4 liter) of clean oil. Change the oil more frequently if the pump is operated continuously or



installed in an environment with rapid temperature change.

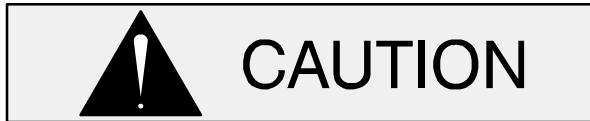

Monitor the condition of the bearing lubricant regularly for evidence of rust or moisture condensation. This is especially important in areas where variable hot and cold temperatures are common.

For cold weather operation, consult the factory or a lubricant supplier for the recommended grade of oil.

### **Power Unit**

Consult the literature supplied with the power unit, or contact your local power unit representative.

**For U.S. and International Warranty Information,  
Please Visit [www.grpumps.com/warranty](http://www.grpumps.com/warranty)  
or call:  
U.S.: 419-755-1280  
International: +1-419-755-1352**

**For Canadian Warranty Information,  
Please Visit [www.grcanada.com/warranty](http://www.grcanada.com/warranty)  
or call:  
519-631-2870**