

**INSTALLATION, OPERATION,
AND MAINTENANCE MANUAL**
WITH PARTS LIST



80 SERIES PUMP

MODEL
83B2-B

GORMAN-RUPP PUMPS

www.grpumps.com

Register your new
Gorman-Rupp pump online at
www.grpumps.com

Valid serial number and e-mail address required.

RECORD YOUR PUMP MODEL AND SERIAL NUMBER

Please record your pump model and serial number in the spaces provided below. Your Gorman-Rupp distributor needs this information when you require parts or service.

Pump Model: _____

Serial Number: _____

TABLE OF CONTENTS

INTRODUCTION	PAGE I – 1
SAFETY - SECTION A	PAGE A – 1
INSTALLATION – SECTION B	PAGE B – 1
Pump Dimensions	PAGE B – 1
PREINSTALLATION INSPECTION	PAGE B – 1
POSITIONING PUMP	PAGE B – 2
Lifting	PAGE B – 2
Mounting	PAGE B – 2
SUCTION AND DISCHARGE PIPING	PAGE B – 2
Materials	PAGE B – 2
Line Configuration	PAGE B – 2
Connections to Pump	PAGE B – 2
Gauges	PAGE B – 3
SUCTION LINES	PAGE B – 3
Fittings	PAGE B – 3
Strainers	PAGE B – 3
Sealing	PAGE B – 3
Suction Lines In Sumps	PAGE B – 3
Suction Line Positioning	PAGE B – 3
DISCHARGE LINES	PAGE B – 4
Siphoning	PAGE B – 4
Valves	PAGE B – 4
Bypass Lines	PAGE B – 4
ALIGNMENT	PAGE B – 4
Coupled Drives	PAGE B – 5
V-Belt Drives	PAGE B – 5
OPERATION – SECTION C	PAGE C – 1
PRIMING	PAGE C – 1
STARTING	PAGE C – 1
Rotation	PAGE C – 1
OPERATION	PAGE C – 2
Lines With a Bypass	PAGE C – 2
Lines Without a Bypass	PAGE C – 2
Leakage	PAGE C – 2
Liquid Temperature And Overheating	PAGE C – 2
Strainer Check	PAGE C – 2
Pump Vacuum Check	PAGE C – 3
STOPPING	PAGE C – 3
Cold Weather Preservation	PAGE C – 3
BEARING TEMPERATURE CHECK	PAGE C – 3
TROUBLESHOOTING – SECTION D	PAGE D – 1
PUMP MAINTENANCE AND REPAIR - SECTION E	PAGE E – 1
STANDARD PERFORMANCE CURVE	PAGE E – 1

TABLE OF CONTENTS
(continued)

PARTS LIST:

Pump Model	PAGE E – 3
PUMP AND SEAL DISASSEMBLY AND REASSEMBLY	PAGE E – 4
Suction Check Valve Disassembly	PAGE E – 4
Pump Casing Removal	PAGE E – 4
Impeller Removal	PAGE E – 5
Seal Removal	PAGE E – 5
Shaft And Bearing Removal And Disassembly	PAGE E – 5
Shaft And Bearing Reassembly And Installation	PAGE E – 6
Seal Reassembly and Installation	PAGE E – 7
Impeller Installation	PAGE E – 9
Pump Casing Installation	PAGE E – 9
Suction Check Valve Installation	PAGE E – 9
Final Pump Assembly	PAGE E – 10
LUBRICATION	PAGE E – 10
Seal Assembly	PAGE E – 10
Bearings	PAGE E – 10
Power Source	PAGE E – 11

INTRODUCTION

Thank You for purchasing a Gorman-Rupp pump. **Read this manual** carefully to learn how to safely install and operate your pump. Failure to do so could result in personal injury or damage to the pump.

Because pump installations are seldom identical, this manual cannot possibly provide detailed instructions and precautions for every aspect of each specific application. Therefore, it is the responsibility of the owner/installer of the pump to ensure that applications not addressed in this manual are performed **only** after establishing that neither operator safety nor pump integrity are compromised by the installation. Pumps and related equipment **must** be installed and operated according to all national, local and industry standards.

If there are any questions regarding the pump or its application which are not covered in this manual or in other literature accompanying this unit, please contact your Gorman-Rupp distributor, or The Gorman-Rupp Company:

The Gorman-Rupp Company
P.O. Box 1217
Mansfield, Ohio 44901—1217
Phone: (419) 755—1011
 or:
Gorman-Rupp of Canada Limited
70 Burwell Road
St. Thomas, Ontario N5P 3R7
Phone: (519) 631—2870

For information or technical assistance on the power source, contact the power source manufacturer's local dealer or representative.

HAZARD AND INSTRUCTION DEFINITIONS

The following are used to alert maintenance personnel to procedures which require special attention, to those which could damage equipment, and to those which could be dangerous to personnel:



Immediate hazards which WILL result in severe personal injury or death. These instructions describe the procedure required and the injury which will result from failure to follow the procedure.



Hazards or unsafe practices which COULD result in severe personal injury or death. These instructions describe the procedure required and the injury which could result from failure to follow the procedure.



Hazards or unsafe practices which COULD result in minor personal injury or product or property damage. These instructions describe the requirements and the possible damage which could result from failure to follow the procedure.

NOTE

Instructions to aid in installation, operation, and maintenance or which clarify a procedure.

SAFETY - SECTION A

This information applies to 80 Series basic pumps. Gorman-Rupp has no control over or particular knowledge of the power source which will be used. Refer to the manual accompanying the power source before attempting to begin operation.

Because pump installations are seldom identical, this manual cannot possibly provide detailed instructions and precautions for each specific application. Therefore, it is the owner/installer's responsibility to ensure that applications not addressed in this manual are performed only after establishing that neither operator safety nor pump integrity are compromised by the installation.



Before attempting to open or service the pump:

1. Familiarize yourself with this manual.
2. Lock out or disconnect the power source to ensure that the pump will remain inoperative.
3. Allow the pump to completely cool if overheated.
4. Check the temperature before opening any covers, plates, or plugs.
5. Close the suction and discharge valves.
6. Vent the pump slowly and cautiously.
7. Drain the pump.



This pump is designed to handle most

non-volatile, non-flammable liquids containing specified entrained solids. Do not attempt to pump liquids for which the pump, driver and/or controls have not been approved, or which may damage the pump or endanger personnel as a result of pump failure.



Death or serious personal injury and damage to the pump or components can occur if proper lifting procedures are not observed. Make certain that hoists, chains, slings or cables are in good working condition and of sufficient capacity and that they are positioned so that loads will be balanced and the pump or components will not be damaged when lifting. Suction and discharge hoses and piping must be removed from the pump before lifting. Lift the pump or component only as high as necessary and keep personnel away from suspended objects.



After the pump has been installed, make certain that the pump and all piping or hose connections are tight, properly supported and secure before operation.



Do not operate the pump without the shields and/or guards in place over the drive shaft, belts, and/or couplings, or other rotating parts. Exposed rotating parts can catch clothing, fingers, or tools, causing severe injury to personnel.

**WARNING!**

Do not operate the pump against a closed discharge valve for long periods of time. If operated against a closed discharge valve, pump components will deteriorate, and the liquid could come to a boil, build pressure, and cause the pump casing to rupture or explode.

**WARNING!**

Overheated pumps can cause severe burns and injuries. If overheating of the pump occurs:

1. Stop the pump immediately.
2. Ventilate the area.
3. Allow the pump to completely cool.
4. Check the temperature before opening any covers, plates, gauges, or plugs.
5. Vent the pump slowly and cautiously.

6. Refer to instructions in this manual before restarting the pump.

**WARNING!**

Do not remove plates, covers, gauges, pipe plugs, or fittings from an overheated pump. Vapor pressure within the pump can cause parts being disengaged to be ejected with great force. Allow the pump to completely cool before servicing.

**WARNING!**

Never run this pump backwards. Be certain that rotation is correct before fully engaging the pump.

**CAUTION**

Pumps and related equipment must be installed and operated according to all national, local and industry standards.

INSTALLATION – SECTION B

Review all SAFETY information in Section A.

Since pump installations are seldom identical, this section offers only general recommendations and practices required to inspect, position, and arrange the pump and piping.

Most of the information pertains to a standard **static lift** application where the pump is positioned above the free level of liquid to be pumped.

If installed in a **flooded suction application** where the liquid is supplied to the pump under pressure, some of the information such as mounting, line

configuration, and priming must be tailored to the specific application. This pump is equipped with a Gorman-Rupp double grease lubricated seal, therefore the maximum incoming pressure must be limited to 10 p.s.i.

For further assistance, contact your Gorman-Rupp distributor or the Gorman-Rupp Company.

Pump Dimensions

See Figure 1 for the approximate physical dimensions of this pump.

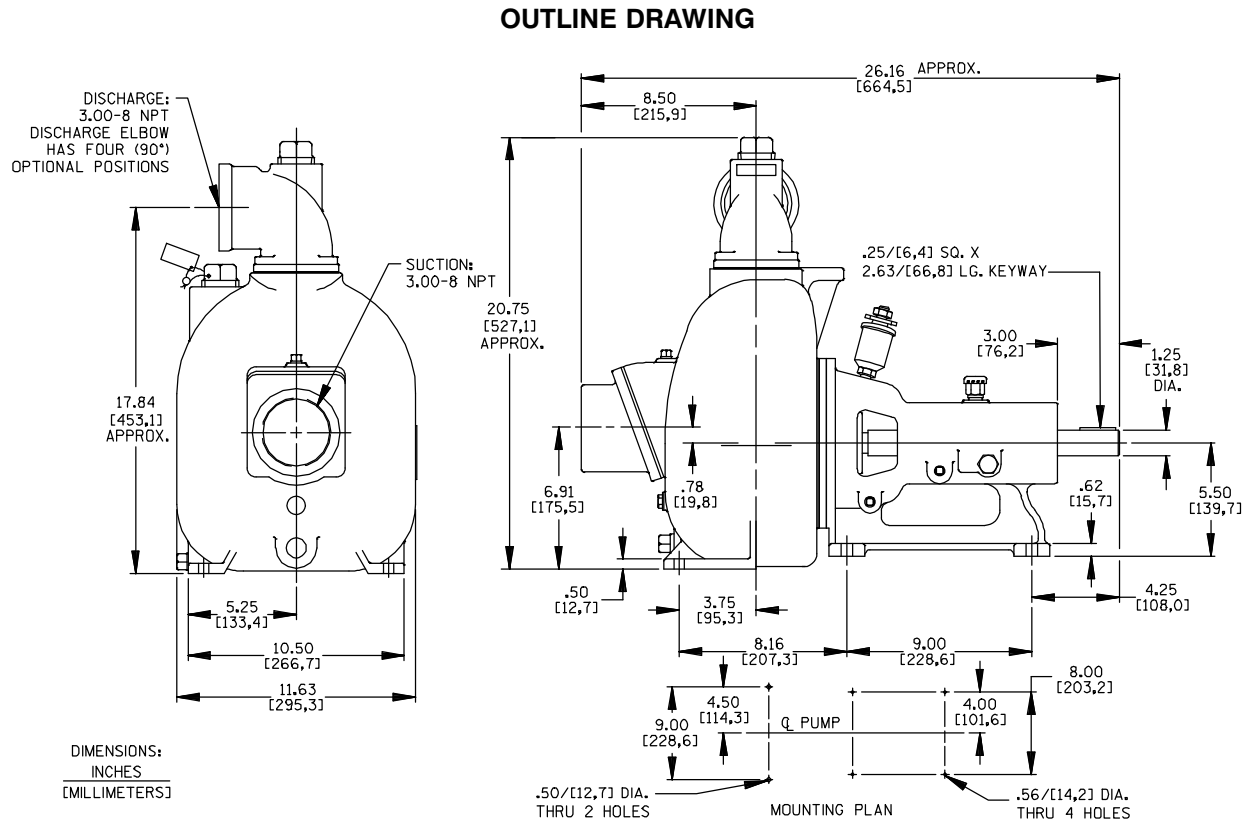

PREINSTALLATION INSPECTION

The pump assembly was inspected and tested before shipment from the factory. Before installation, inspect the pump for damage which may have occurred during shipment. Check as follows:

- a. Inspect the pump for cracks, dents, damaged threads, and other obvious damage.

- b. Check for and tighten loose attaching hardware. Since gaskets tend to shrink after drying, check for loose hardware at mating surfaces.
- c. Carefully read all tags, decals, and markings on the pump assembly, and perform all duties indicated.



Only operate this pump in the direction indicated by the arrow on the pump body and on the accompanying decal. Otherwise, the impeller could become loosened from the shaft and seriously damage the pump. Refer to **Rotation** in **OPERATION**, Section C.

- d. Check levels and lubricate as necessary. Refer to **LUBRICATION** in the **MAINTENANCE AND REPAIR** section of this manual and perform duties as instructed.
- e. If the pump has been stored for more than 12 months, some of the components or lubricants may have exceeded their maximum shelf life. These **must be inspected or replaced** to ensure maximum pump service.

If the maximum shelf life has been exceeded, or if anything appears to be abnormal, contact your Gorman-Rupp distributor or the factory to determine the repair or updating policy. **Do not** put the pump into service until appropriate action has been taken.

POSITIONING PUMP



Death or serious personal injury and damage to the pump or components can occur if proper lifting procedures are not observed. Make certain that hoists, chains, slings or cables are in good working condition and of sufficient capacity and that they are positioned so that loads will be balanced and the pump or components will not be damaged when lifting. Suction and discharge hoses and piping must be removed from the pump before lifting. Lift the pump or component only as high as necessary and keep personnel away from suspended objects.

Lifting

Pump unit weights will vary depending on the mounting and drive provided. Check the shipping tag on the unit packaging for the actual weight, and use lifting equipment with appropriate capacity. Drain the pump and remove all customer-installed equipment such as suction and discharge hoses or piping before attempting to lift existing, installed units.

Mounting

Locate the pump in an accessible place as close as practical to the liquid being pumped. Level mounting is essential for proper operation.

The pump may have to be supported or shimmed to provide for level operation or to eliminate vibration.

SUCTION AND DISCHARGE PIPING

Pump performance is adversely effected by increased suction lift, discharge elevation, and friction losses. See the performance curve on Page E-1 to be sure your overall application allows pump to operate within the safe operation range.

Materials

Either pipe or hose maybe used for suction and discharge lines; however, the materials must be compatible with the liquid being pumped. If hose is used in suction lines, it must be the rigid-wall, reinforced type to prevent collapse under suction. Using piping couplings in suction lines is not recommended.

Line Configuration

Keep suction and discharge lines as straight as possible to minimize friction losses. Make minimum use of elbows and fittings, which substantially increase friction loss. If elbows are necessary, use the long-radius type to minimize friction loss.

Connections to Pump

Before tightening a connecting flange, align it exactly with the pump port. Never pull a pipe line into

place by tightening the flange bolts and/or couplings.

Lines near the pump must be independently supported to avoid strain on the pump which could cause excessive vibration, decreased bearing life, and increased shaft and seal wear. If hose-type lines are used, they should have adequate support to secure them when filled with liquid and under pressure.

Gauges

Most pumps are drilled and tapped for installing discharge pressure and vacuum suction gauges. If these gauges are desired for pumps that are not tapped, drill and tap the suction and discharge lines not less than 18 inches (457,2 mm) from the suction and discharge ports and install the lines. Installation closer to the pump may result in erratic readings.

SUCTION LINES

To avoid air pockets which could affect pump priming, the suction line must be as short and direct as possible. When operation involves a suction lift, the line must always slope upward to the pump from the source of the liquid being pumped; if the line slopes down to the pump at any point along the suction run, air pockets will be created.

Fittings

Suction lines should be the same size as the pump inlet. If reducers are used in suction lines, they should be the eccentric type, and should be installed with the flat part of the reducers uppermost to avoid creating air pockets. Valves are not normally used in suction lines, but if a valve is used, install it with the stem horizontal to avoid air pockets.

Strainers

If a strainer is furnished with the pump, be certain to use it; any spherical solids which pass through a strainer furnished with the pump will also pass through the pump itself.

If a strainer is not furnished with the pump, but is installed by the pump user, make certain that the

total area of the openings in the strainer is at least three or four times the cross section of the suction line, and that the openings will not permit passage of solids larger than the solids handling capability of the pump.

This pump is designed to handle up to 13/16-inch (20,6 mm) diameter spherical solids.

Sealing

Since even a slight leak will affect priming, head, and capacity, especially when operating with a high suction lift, all connections in the suction line should be sealed with pipe dope to ensure an air-tight seal. Follow the sealant manufacturer's recommendations when selecting and applying the pipe dope. The pipe dope should be compatible with the liquid being pumped.

Suction Lines In Sumps

If a single suction line is installed in a sump, it should be positioned away from the wall of the sump at a distance equal to 1-1/2 times the diameter of the suction line.

If there is a liquid flow from an open pipe into the sump, the flow should be kept away from the suction inlet because the inflow will carry air down into the sump, and air entering the suction line will reduce pump efficiency.

If it is necessary to position inflow close to the suction inlet, install a baffle between the inflow and the suction inlet at a distance 1-1/2 times the diameter of the suction pipe. The baffle will allow entrained air to escape from the liquid before it is drawn into the suction inlet.

If two suction lines are installed in a single sump, the flow paths may interact, reducing the efficiency of one or both pumps. To avoid this, position the suction inlets so that they are separated by a distance equal to at least 3 times the diameter of the suction pipe.

Suction Line Positioning

The depth of submergence of the suction line is critical to efficient pump operation. Figure 2 shows recommended minimum submergence vs. velocity.

NOTE

The pipe submergence required may be reduced by installing a standard pipe increaser fitting at the end of the suction line. The larger opening size will

reduce the inlet velocity. Calculate the required submergence using the following formula based on the increased opening size (area or diameter).

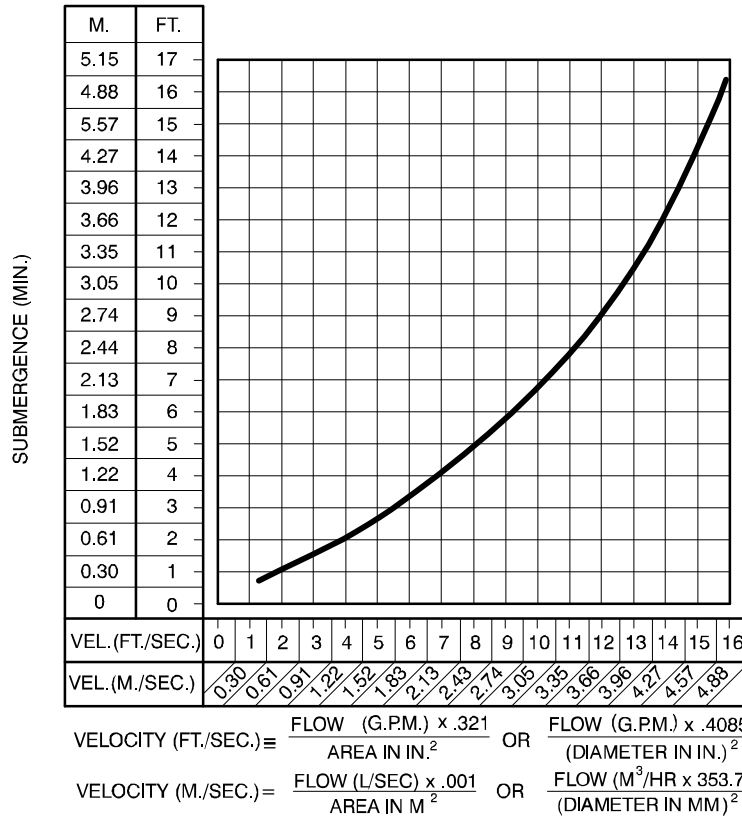

Figure 2. Recommended Minimum Suction Line Submergence vs. Velocity

DISCHARGE LINES

Siphoning

Do not terminate the discharge line at a level lower than that of the liquid being pumped unless a siphon breaker is used in the line. Otherwise, a siphoning action causing damage to the pump could result.

Valves

If a throttling valve is desired in the discharge line, use a valve as large as the largest pipe to minimize friction losses. Never install a throttling valve in a suction line.

With high discharge heads, it is recommended that a throttling valve and a system check valve be installed in the discharge line to protect the pump

from excessive shock pressure and reverse rotation when it is stopped.



If the application involves a high discharge head, gradually close the discharge throttling valve before stopping the pump.

Bypass Lines

If a system check valve is used due to high discharge head, it may be necessary to vent trapped air from the top of the pump during the priming process. This may be accomplished by installing a bypass line from the top of the pump, back to the source of liquid. The end of the bypass line must be submerged. The line must be large enough to prevent clogging, but not so large as to affect pump discharge capacity.

ALIGNMENT

The alignment of the pump and its power source is critical for trouble-free mechanical operation. In either a flexible coupling or V-belt driven system, the driver and pump must be mounted so that their shafts are aligned with and parallel to each other. It is imperative that alignment be checked after the pump and piping are installed, and before operation.

NOTE

Check **Rotation**, Section C, before final alignment of the pump.

When mounted at the Gorman-Rupp factory, driver and pump are aligned before shipment. Misalignment will occur in transit and handling. Pumps **must** be checked and realigned before operation. Before checking alignment, tighten the foundation bolts. The pump casing feet and/or pedestal feet, and the driver mounting bolts should also be tightly secured.



When checking alignment, disconnect the power source to ensure that the pump will remain inoperative.



Adjusting the alignment in one direction may alter the alignment in another direction. Check each procedure after altering alignment.

Coupled Drives

When using couplings, the axis of the power source must be aligned to the axis of the pump shaft in both the horizontal and vertical planes. Most couplings require a specific gap or clearance between the driving and the driven shafts. Refer to the coupling manufacturer's service literature.

Align spider insert type couplings by using calipers to measure the dimensions on the circumference

of the outer ends of the coupling hub every 90 degrees. The coupling is in alignment when the hub ends are the same distance apart at all points (see Figure 3A).

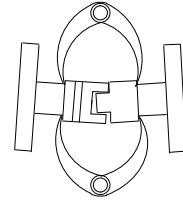

Figure 3A. Aligning Spider Type Couplings

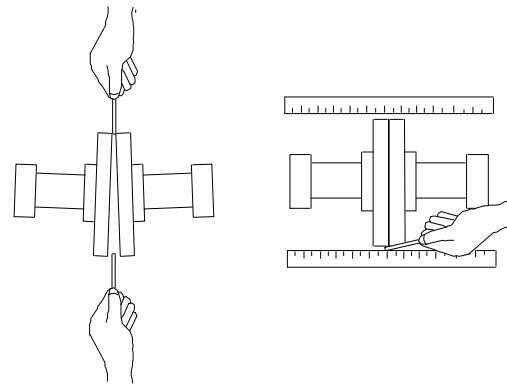

Figure 3B. Aligning Non-Spider Type Couplings

Align non-spider type couplings by using a feeler gauge or taper gauge between the coupling halves every 90 degrees. The coupling is in alignment when the hubs are the same distance apart at all points (see Figure 3B).

Check parallel adjustment by laying a straightedge across both coupling rims at the top, bottom, and side. When the straightedge rests evenly on both halves of the coupling, the coupling is in horizontal parallel alignment. If the coupling is misaligned, use a feeler gauge between the coupling and the straightedge to measure the amount of misalignment.

V-Belt Drives

When using V-belt drives, the power source and the pump must be parallel. Use a straightedge along the sides of the pulleys to ensure that the pulleys are properly aligned (see Figure 3C). In drive systems using two or more belts, make certain that

the belts are a matched set; unmatched sets will cause accelerated belt wear.

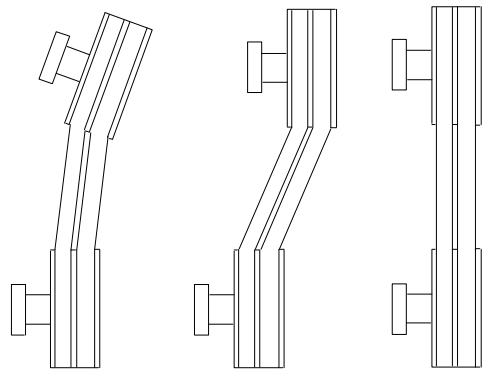

MISALIGNED: SHAFTS NOT PARALLEL **MISALIGNED: SHAFTS NOT IN LINE** **ALIGNED: SHAFTS PARALLEL AND SHEAVES IN LINE**
Figure 3C. Alignment of V-Belt Driven Pumps

Tighten the belts in accordance with the belt manufacturer’s instructions. If the belts are too loose, they will slip; if the belts are too tight, there will be excessive power loss and possible bearing failure. Select pulleys that will match the proper speed ratio; overspeeding the pump may damage both pump and power source.



WARNING!

Do not operate the pump without the shields and/or guards in place over the drive shaft, belts, and/or couplings, or other rotating parts. Exposed rotating parts can catch clothing, fingers, or tools, causing severe injury to personnel.

V-BELT TENSIONING

General Rules of Tensioning

For new v-belts, check the tension after 5, 20 and 50 hours of operation and re-tension as required (see the following procedure for measuring belt tension). Thereafter, check and re-tension if required monthly or at 500 hour intervals, whichever comes first.

Ideal v-belt tension is the **lowest** tension at which the belt will not slip under peak load conditions. Do not over-tension v-belts. Over-tensioning will short-

en both v-belt and bearing life. Under-tensioning will cause belt slippage. Always keep belts free from dirt, grease, oil and other foreign material which may cause slippage.

Tension Measurement

Correct v-belt tension can be achieved using a v-belt tension tester and Table 1 or 2. Use the tables to find the v-belt size (cross-section), the smallest sheave diameter, the belt type for your application. The corresponding deflection force required for new or used belts is shown opposite the RPM range of the pump.

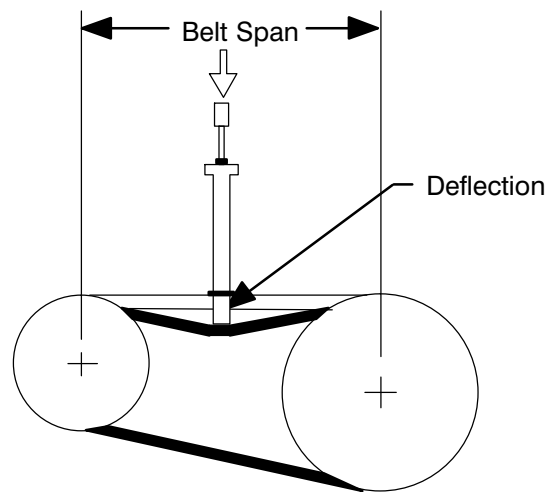

Figure 4. Belt Tension Measurement

The ratio of deflection to belt span is 1:64 for both ASA and metric units. Therefore, a belt with a span of 64 inches would require a deflection of 1 inch at the force shown on the Tables for your particular application.

For example, if the span as measured in Figure 4 is 32 inches (813 mm), the v-belt cross-section is C, the smallest sheave diameter is 8 inches, the pump speed is 1250 RPM, and the belts are uncogged Yy-T type, then 11.5 lbs. of force on the tensioner should show 1/2-inch (12,7 mm) of deflection.

A tension tester is available as an option from Gorman-Rupp (P/N 29513—001). Other tension testers are available from your local belt/sheave distributor, and work on a similar principal.

To use the Gorman-Rupp tensioner, measure the belt span as shown in Figure 4. Position the bottom of the large O-ring on the span scale of the tension-

er at the measured belt span. Set the small O-ring on the deflection force scale to zero.

Place the tension tester squarely on the belt at the center of the belt span. Apply force on the plunger, perpendicular to the belt span, until the bottom of the large O-ring is even with the top of the next belt, or with the bottom of a straight edge laid across the sheaves.

Read the force applied from the bottom of the small O-ring on the deflection force scale. Compare this force with the value shown in Table 1 or 2 and adjust the tension accordingly. Note that the **tension for new belts is higher than that for used belts** to allow for expected belt stretching. **Do not** over-tension used belts to the higher deflection forces shown for new belts.

**Table 1. Sheave Diameter (Inches)
Deflection Force (Lbs.)**

Cross Section	Smallest Sheave Diameter Range	R.P.M. Range	Belt Deflection Force			
			Uncogged Hy-T Belts & Uncogged Hy-T Torque Team		Cogged Torque-Flex & Machined Edge torque Team Belts	
			Used Belt	New Belt	Used Belt	New Belt
A,AX	3.0 - 3.6	1000-2500 2501-4000	3.7 2.8	5.5 4.2	4.1 3.4	6.1 5.0
	3.8 - 4.8	1000-2500 2501-4000	4.5 3.8	6.8 5.7	5.0 4.3	7.4 6.4
	5.0 - 7.0	1000-2500 2501-4000	5.4 4.7	8.0 7.0	5.7 5.1	9.4 7.4
B,BX	3.4 - 4.2	860-2500 2501-4000			4.9 4.2	7.2 6.2
	4.4 - 5.6	860-2500 2501-4000	5.3 4.5	7.9 6.7	7.1 7.1	10.5 9.1
	5.8 - 8.6	860-2500 2501-4000	6.3 6.0	9.4 8.9	8.5 7.3	12.6 10.9
C,CX	7.0 - 9.0	500-1740 1741-3000	11.5 9.4	17.0 13.8	14.7 11.9	21.8 17.5
	9.5 - 16.0	500-1740 1741-3000	14.1 12.5	21.0 18.5	15.9 14.6	23.5 21.6
D	12.0 - 16.0	200-850 851-1500	11.5 9.4	17.0 13.8	14.7 11.9	21.8 17.5
	18.0 - 20.0	200-850 851-1500	30.4 25.6	45.2 38.0		
3V, 3VX	2.2 - 2.4	1000-2500 2501-4000			3.3 2.9	4.9 4.3
	2.65 - 3.65	1000-2500 2501-4000	3.6 3.0	5.1 4.4	4.2 3.8	6.2 5.6
	4.12 - 6.90	1000-2500 2501-4000	4.9 4.4	7.3 6.6	5.3 4.9	7.9 7.3
5V, 5VX	4.4 - 6.7	500-1749 1750-3000 3001-4000			10.2 8.8 5.6	15.2 13.2 8.5
	7.1 - 10.9	500-1740 1741-3000	12.7 11.2	18.9 16.7	14.8 13.7	22.1 20.1
	11.8 - 16.0	500-1740 1741-3000	15.5 14.6	23.4 21.8	17.1 16.8	25.5 25.0
8V	12.5 - 17.0	200-850 851-1500	33.0 26.8	49.3 39.9		
	18.0 - 22.4	200-850 851-1500	39.6 35.3	59.2 52.7		

**Table 2. Sheave Diameter (Millimeters)
Deflection Force (KG.)**

Cross Section	Smallest Sheave Diameter Range	R.P.M. Range	Belt Deflection Force			
			Uncogged Hy-T Belts & Uncogged Hy-T Torque Team		Cogged Torque-Flex & Machined Edge torque Team Belts	
			Used Belt	New Belt	Used Belt	New Belt
A,AX	75 - 90	1000-2500 2501-4000	1.7 1.3	2.5 1.9	1.9 1.5	2.8 2.3
	91 - 120	1000-2500 2501-4000	2.0 1.7	3.1 2.6	2.3 2.0	3.4 2.9
	125 - 175	1000-2500 2501-4000	2.4 2.1	3.6 3.2	2.6 2.3	4.3 3.4
B,BX	85 - 105	860-2500 2501-4000			2.2 1.9	3.3 2.8
	106 - 140	860-2500 2501-4000	2.4 2.0	3.6 3.0	3.2 3.2	4.8 4.1
	141 - 220	860-2500 2501-4000	2.9 2.7	4.3 4.0	3.9 3.3	5.7 4.9
C,CX	175 - 230	500-1740 1741-3000	5.2 4.3	7.7 6.3	6.7 5.4	9.9 7.9
	231 - 400	500-1740 1741-3000	6.4 5.7	9.5 8.4	7.2 6.6	10.7 9.8
D	305 - 400	200-850 851-1500	11.3 9.6	16.8 14.2		
	401 - 510	200-850 851-1500	13.8 11.6	20.5 17.2		
3V, 3VX	55 - 60	1000-2500 2501-4000			1.5 1.3	2.2 2.0
	61 - 90	1000-2500 2501-4000	1.6 1.4	2.3 2.0	1.9 1.7	2.8 2.5
	91 - 175	1000-2500 2501-4000	2.2 2.0	3.3 3.0	2.4 2.2	3.6 3.3
5V, 5VX	110 - 170	500-1749 1750-3000 3001-4000			4.6 4.0 2.5	6.9 6.0 3.9
	171 - 1275	500-1740 1741-3000	5.8 5.1	8.6 7.6	6.7 6.2	10.0 9.1
	276 - 400	500-1740 1741-3000	7.0 6.6	10.6 9.9	7.8 7.6	11.6 11.3
8V	315 - 430	200-850 851-1500	15.0 12.2	22.4 18.1		
	431 - 570	200-850 851-1500	18.0 16.0	26.8 23.9		

OPERATION – SECTION C

Review all **SAFETY** information in Section A.

Follow the instructions on all tags, labels and decals attached to the pump.



This pump is designed to handle most non-volatile, non-flammable liquids containing specified entrained solids. Do not attempt to pump liquids for which the pump, driver and/or controls have not been approved, or which may damage the pump or endanger personnel as a result of pump failure.



Pump speed and operating condition points must be within the continuous performance range shown on the curve (see Section E, Page 1).

PRIMING

Install the pump and piping as described in **INSTALLATION**. Make sure that the piping connections are tight, and that the pump is securely mounted. Check that the pump is properly lubricated (see **LUBRICATION** in **MAINTENANCE AND REPAIR**).

This pump is self-priming, but the pump should never be operated unless there is liquid in the pump casing.

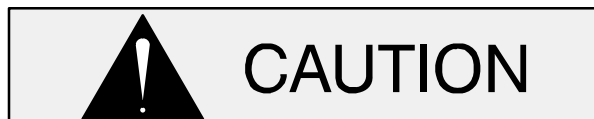

Never operate this pump unless there is liquid in the pump casing. The pump will not prime when dry. Extended operation of a dry pump will destroy the seal assembly.

Add liquid to the pump casing when:

1. The pump is being put into service for the first time.
2. The pump has not been used for a considerable length of time.
3. The liquid in the pump casing has evaporated.

Once the pump casing has been filled, the pump will prime and reprime as necessary.



After filling the pump casing, reinstall and tighten the fill plug. Do not attempt to operate the pump unless all connecting piping is securely installed. Otherwise, liquid in the pump forced out under pressure could cause injury to personnel.

To fill the pump, remove the pump casing fill cover or fill plug in the top of the casing, and add clean liquid until the casing is filled. Replace the fill cover or fill plug before operating the pump.

STARTING

Consult the operations manual furnished with the power source.

Rotation

The correct direction of pump rotation is counter-clockwise when facing the impeller. If the pump is operated in the wrong direction, the impeller could become loosened from the shaft and seriously damage the pump.



Only operate this pump in the direction indicated by the arrow on the pump body and on the accompanying decal. Otherwise, the impeller could become loosened

from the shaft and seriously damage the pump.

Consult the operating manual furnished with the power source before attempting to start the power source.

If an electric motor is used to drive the pump, remove V-belts, couplings, or otherwise disconnect the pump from the motor before checking motor rotation. Operate the motor independently while observing the direction of the motor shaft, or cooling fan.

If rotation is incorrect on a three-phase motor, have a qualified electrician interchange any two of the three phase wires to change direction. If rotation is incorrect on a single-phase motor, consult the literature supplied with the motor for specific instructions.

OPERATION

Lines With a Bypass

Close the discharge throttling valve (if so equipped) so that the pump will not have to prime against the weight of the liquid in the discharge line. Air from the suction line will be discharged through the bypass line back to the wet well during the priming cycle. When the pump is fully primed and liquid is flowing steadily from the bypass line, open the discharge throttling valve. Liquid will then continue to circulate through the bypass line while the pump is in operation.

Lines Without a Bypass

Open all valves in the discharge line and start the engine. Priming is indicated by a positive reading on the discharge pressure gauge or by a quieter operation. The pump may not prime immediately because the suction line must first fill with liquid. If the pump fails to prime within five minutes, stop it and check the suction line for leaks.

After the pump has been primed, partially close the discharge line throttling valve in order to fill the line slowly and guard against excessive shock pressure which could damage pipe ends, gaskets,

sprinkler heads, and any other fixtures connected to the line. When the discharge line is completely filled, adjust the throttling valve to the required flow rate.

Leakage

No leakage should be visible at pump mating surfaces, or at pump connections or fittings. Keep all line connections and fittings tight to maintain maximum pump efficiency.

Liquid Temperature And Overheating

The **maximum** liquid temperature for this pump is 160° F (71° C). Do not apply it at a higher operating temperature.

Overheating can occur if operated with the valves in the suction or discharge lines closed. Operating against closed valves could bring the liquid to a boil, build pressure, and cause the pump to rupture or explode. If overheating occurs, stop the pump and allow it to completely cool before servicing it. Refill the pump casing with cool liquid.



Do not remove plates, covers, gauges, pipe plugs, or fittings from an overheated pump. Vapor pressure within the pump can cause parts being disengaged to be ejected with great force. Allow the pump to completely cool before servicing.

Strainer Check

If a suction strainer has been shipped with the pump or installed by the user, check the strainer regularly, and clean it as necessary. The strainer should also be checked if pump flow rate begins to drop. If a vacuum suction gauge has been installed, monitor and record the readings regularly to detect strainer blockage.

Never introduce air or steam pressure into the pump casing or piping to remove a blockage. This could result in personal injury or damage to the

equipment. If backflushing is absolutely necessary, **liquid pressure** must be limited to 50% of the maximum permissible operating pressure shown on the pump performance curve (see Section E, Page 1).

Pump Vacuum Check

With the pump inoperative, install a vacuum gauge in the system, using pipe dope on the threads. Block the suction line and start the pump. At operating speed the pump should pull a vacuum of 20 inches (508,0 mm) or more of mercury. If it does not, check for air leaks in the seal, gasket, or discharge valve.

Open the suction line, and read the vacuum gauge with the pump primed and at operation speed. Shut off the pump. The vacuum gauge reading will immediately drop proportionate to static suction lift, and should then stabilize. If the vacuum reading falls off rapidly after stabilization, an air leak exists. Before checking for the source of the leak, check the point of installation of the vacuum gauge.

STOPPING

Never halt the flow of liquid suddenly. If the liquid being pumped is stopped abruptly, damaging shock waves can be transmitted to the pump and piping system. Close all connecting valves slowly.



If the application involves a high discharge head, gradually close the discharge throttling valve before stopping the pump.

After stopping the pump, lock out or disconnect the power source to ensure that the pump will remain inoperative.

Cold Weather Preservation

In below freezing conditions, drain the pump to prevent damage from freezing. Also, clean out any solids by flushing with a hose. Operate the pump for approximately one minute; this will remove any remaining liquid that could freeze the pump rotating parts. If the pump will be idle for more than a few hours, or if it has been pumping liquids containing a large amount of solids, drain the pump, and flush it thoroughly with clean water. To prevent large solids from clogging the drain port and preventing the pump from completely draining, insert a rod or stiff wire in the drain port, and agitate the liquid during the draining process. Clean out any remaining solids by flushing with a hose.

BEARING TEMPERATURE CHECK

Bearings normally run at higher than ambient temperatures because of heat generated by friction. Temperatures up to 160°F (71°C) are considered normal for bearings, and they can operate safely to at least 180°F (82°C).

Checking bearing temperatures by hand is inaccurate. Bearing temperatures can be measured accurately by placing a contact-type thermometer against the housing. Record this temperature for future reference.

A sudden increase in bearing temperatures is a warning that the bearings are at the point of failing to operate properly. Make certain that the bearing lubricant is of the proper viscosity and at the correct level (see **LUBRICATION** in Section E). Bearing overheating can also be caused by shaft misalignment and/or excessive vibration.

When pumps are first started, the bearings may seem to run at temperatures above normal. Continued operation should bring the temperatures down to normal levels.

TROUBLESHOOTING – SECTION D

Review all SAFETY information in Section A.



Before attempting to open or service the pump:

1. Familiarize yourself with this manual.
2. Lock out or disconnect the power source to ensure that the pump will remain inoperative.
3. Allow the pump to completely cool if overheated.
4. Check the temperature before opening any covers, plates, or plugs.
5. Close the suction and discharge valves.
6. Vent the pump slowly and cautiously.
7. Drain the pump.

TROUBLE	POSSIBLE CAUSE	PROBABLE REMEDY
PUMP FAILS TO PRIME	Not enough liquid in casing. Suction check valve contaminated or damaged. Air leak in suction line. Lining of suction hose collapsed. Leaking or worn seal or pump gasket. Suction lift or discharge head too high. Strainer clogged.	Add liquid to casing. See PRIMING . Clean or replace check valve. Correct leak. Replace suction hose. Check pump vacuum. Replace leaking or worn seal or gasket. Check piping installation and install bypass line if needed. See INSTALLATION . Check strainer and clean if necessary.
PUMP STOPS OR FAILS TO DELIVER RATED FLOW OR PRESSURE	Air leak in suction line. Lining of suction hose collapsed. Leaking or worn seal or pump gasket. Strainer clogged. Suction intake not submerged at proper level or sump too small.	Correct leak. Replace suction hose. Check pump vacuum. Replace leaking or worn seal or gasket. Check strainer and clean if necessary. Check installation and correct submergence as needed.

TROUBLE	POSSIBLE CAUSE	PROBABLE REMEDY
PUMP STOPS OR FAILS TO DELIVER RATED FLOW OR PRESSURE (cont.)	<p>Impeller or other wearing parts worn or damaged.</p> <p>Impeller clogged.</p> <p>Pump speed too slow.</p> <p>Discharge head too high.</p> <p>Suction lift too high.</p>	<p>Replace worn or damaged parts. Check that impeller is properly centered and rotates freely.</p> <p>Free impeller of debris.</p> <p>Check driver output; check belts or couplings for slippage.</p> <p>Install bypass line.</p> <p>Measure lift w/vacuum gauge. Reduce lift and/or friction losses in suction line.</p>
PUMP REQUIRES TOO MUCH POWER	<p>Pump speed too high.</p> <p>Discharge head too low.</p> <p>Liquid solution too thick.</p> <p>Bearing(s) frozen.</p>	<p>Check driver output; check that sheaves or couplings are correctly sized.</p> <p>Adjust discharge valve.</p> <p>Dilute if possible.</p> <p>Disassemble pump and check bearing(s).</p>
PUMP CLOGS FREQUENTLY	<p>Liquid solution too thick.</p> <p>Discharge flow too slow.</p> <p>Suction check valve or foot valve clogged or binding.</p>	<p>Dilute if possible.</p> <p>Open discharge valve fully to increase flow rate, and run power source at maximum governed speed.</p> <p>Clean valve.</p>
EXCESSIVE NOISE	<p>Cavitation in pump.</p> <p>Pumping entrained air.</p> <p>Pump or drive not securely mounted.</p> <p>Impeller clogged or damaged.</p>	<p>Reduce suction lift and/or friction losses in suction line. Record vacuum and pressure gauge readings and consult local representative or factory.</p> <p>Locate and eliminate source of air bubble.</p> <p>Secure mounting hardware.</p> <p>Clean out debris; replace damaged parts.</p>
BEARINGS RUN TOO HOT	<p>Bearing temperature is high, but within limits.</p> <p>Low or incorrect lubricant.</p> <p>Suction and discharge lines not properly supported.</p> <p>Drive misaligned.</p>	<p>Check bearing temperature regularly to monitor any increase.</p> <p>Check for proper type and level of lubricant.</p> <p>Check piping installation for proper support.</p> <p>Align drive properly.</p>

PREVENTIVE MAINTENANCE

Since pump applications are seldom identical, and pump wear is directly affected by such things as the abrasive qualities, pressure and temperature of the liquid being pumped, this section is intended only to provide general recommendations and practices for preventive maintenance. Regardless of the application however, following a routine preventive maintenance schedule will help assure trouble-free performance and long life from your Gorman-Rupp pump. For specific questions concerning your application, contact your Gorman-Rupp distributor or the Gorman-Rupp Company.

Record keeping is an essential component of a good preventive maintenance program. Changes in suction and discharge gauge readings (if so

equipped) between regularly scheduled inspections can indicate problems that can be corrected before system damage or catastrophic failure occurs. The appearance of wearing parts should also be documented at each inspection for comparison as well. Also, if records indicate that a certain part (such as the seal) fails at approximately the same duty cycle, the part can be checked and replaced before failure occurs, reducing unscheduled down time.

For new applications, a first inspection of wearing parts at 250 hours will give insight into the wear rate for your particular application. Subsequent inspections should be performed at the intervals shown on the chart below. Critical applications should be inspected more frequently.

Preventive Maintenance Schedule					
Item	Service Interval*				
	Daily	Weekly	Monthly	Semi-Annually	Annually
General Condition (Temperature, Unusual Noises or Vibrations, Cracks, Leaks, Loose Hardware, Etc.)	I				
Pump Performance (Gauges, Speed, Flow)	I				
Bearing Lubrication		I			R
Seal Lubrication (And Packing Adjustment, If So Equipped)		I			R
V-Belts (If So Equipped)			I		
Air Release Valve Plunger Rod (If So Equipped)			I	C	
Front Impeller Clearance (Wear Plate)				I	
Rear Impeller Clearance (Seal Plate)				I	
Check Valve					I
Pressure Relief Valve (If So Equipped)					C
Pump and Driver Alignment					I
Shaft Deflection					I
Bearings					I
Bearing Housing					I
Piping					I
Driver Lubrication – See Mfgr’s Literature					I

Legend:
 I = Inspect, Clean, Adjust, Repair or Replace as Necessary
 C = Clean
 R = Replace

* Service interval based on an intermittent duty cycle equal to approximately 4000 hours annually. Adjust schedule as required for lower or higher duty cycles or extreme operating conditions.

PUMP MAINTENANCE AND REPAIR – SECTION E

MAINTENANCE AND REPAIR OF THE WEARING PARTS OF THE PUMP WILL MAINTAIN PEAK OPERATING PERFORMANCE.

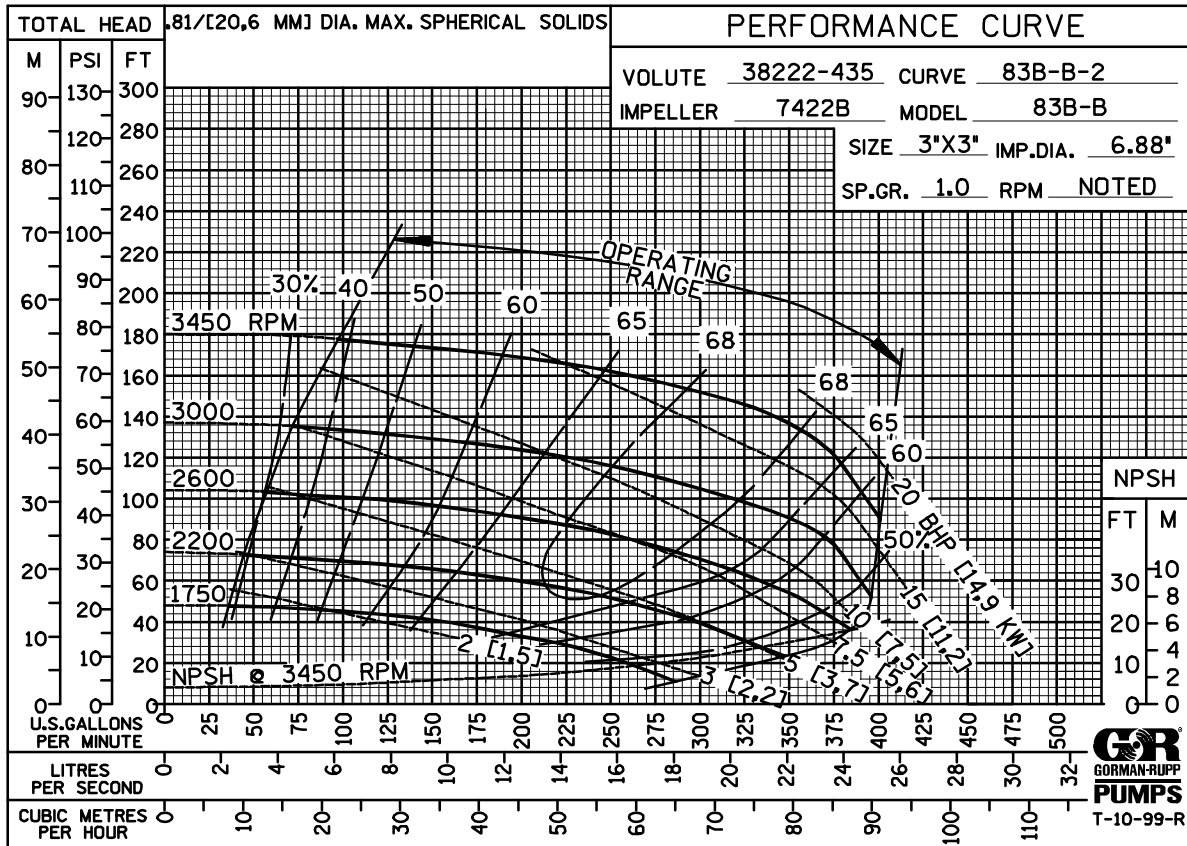

* STANDARD PERFORMANCE FOR PUMP MODEL 83B2-B

* Based on 70° F (21° C) clear water at sea level with minimum suction lift. Since pump installations are seldom identical, your performance may be difference due to such factors as viscosity, specific gravity, elevation, temperature, and impeller trim.

Contact the Gorman-Rupp Company to verify performance or part numbers.

If your pump serial number is followed by an "N", your pump is **NOT** a standard production model.



Pump speed and operating condition points must be within the continuous performance range shown on the curve.

SECTION DRAWING

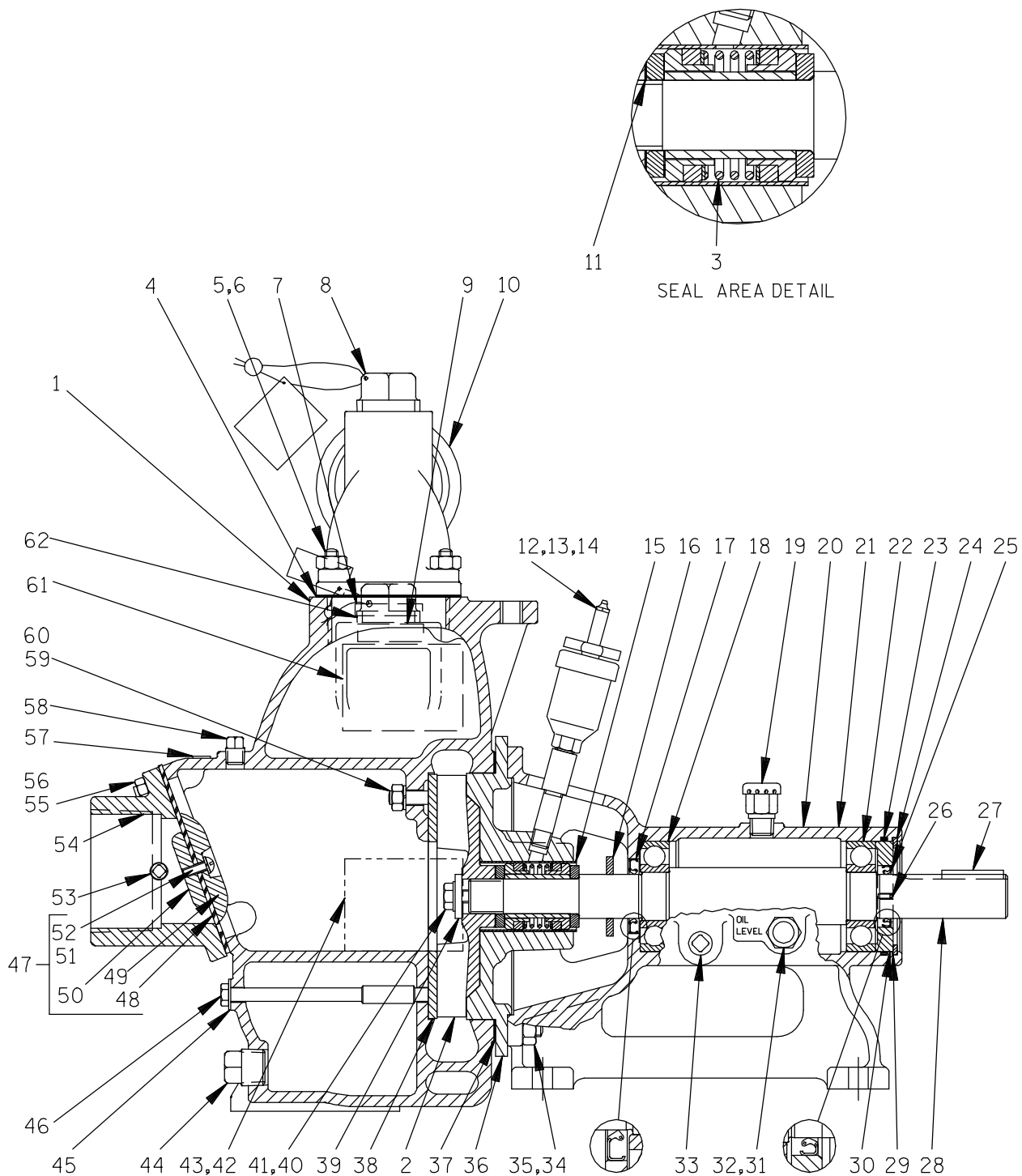

Figure 1. Pump Model 83B2-B

PARTS LIST
Pump Model 83B2-B
 (From S/N 1063841 Up)

If your pump serial number is followed by an "N", your pump is **NOT** a standard production model. Contact the Gorman-Rupp Company to verify part numbers.

ITEM NO.	PART NAME	PART NUMBER	MAT'L CODE	QTY	ITEM NO.	PART NAME	PART NUMBER	MAT'L CODE	QTY
1	PUMP CASING	38222-435	10000	1	36	SEAL PLATE ASSY	392A	10010	1
2 *	IMPELLER	7422B	10010	1	37 *	CASING GASKET SET	3G	18000	1
3 *	SEAL ASSY	GS1000	----	1	38 *	WEAR PLATE ASSY	2899A	15990	1
4 *	DISCH FLANGE GSKT	543G	18000	1	39	WASHER	3118	15990	1
5	STUD	C0607	15991	4	40	HEX HD CAPSCREW	B0604	15991	1
6	HEX NUT	D06	15991	4	41	T-TYPE LOCKWASHER	AK06	15991	1
7	DISCH STICKER	6588BJ	----	1	42	NAME PLATE	38818-022	13990	1
8	FILL PLUG ASSY	48271-066	----	1	43	DRIVE SCREW	BM#04-03	17000	4
9	PRIMING STICKER	6588AH	----	1	44	CASING DRAIN PLUG	P12	15079	1
10	DISCH FLANGE	543	10010	1	45 *	FIBER WASHER	KF06	18040	1
11 *	IMPELLER ADJ SHIM SET	2X	17090	REF	46	HEX HD CAPSCREW	B0618	15991	1
12	GREASE CUP	S36	----	1	47	FLAP VALVE ASSY	544A	----	1
13	PIPE COUPLING	AE04	15079	1	48 *	-FLAP VALVE GASKET	544G	19070	1
14	PIPE NIPPLE	T0408	15079	1	49	-LG VALVE WEIGHT	1364	10010	1
15 *	SEAL LINER	83	14080	REF	50	-SM VALVE WEIGHT	18	10010	1
16	SLINGER RING	3272	19120	1	51	-RD HD MACH SCREW	X0403	17090	1
17 *	INBOARD OIL SEAL	25227-311	----	1	52	-LOCKWASHER	J04	17090	1
18 *	INBOARD BALL BRG	23275-008	----	1	53	ACCESSORY PLUG	P04	15079	1
19	AIR VENT	S1703	----	1	54	SUCTION FLANGE	2946	10010	1
20	PEDESTAL	3114B	10010	1	55	STUD	C0606	15991	4
21	ROTATION DECAL	2613M	----	1	56	HEX NUT	D06	15991	4
22 *	OUTBOARD BALL BRG	23275-008	----	1	57	SUCTION STICKER	6588AG	----	1
23 *	BRG RETAINER O-RING	25152-235	----	1	58	ACCESSORY PLUG	P04	15079	1
24	RETAINING RING	S247	----	1	59	HEX NUT	D06	15991	1
25 *	BRG RET OIL SEAL	25227-303	----	1	60	LOCKWASHER	J06	15991	1
26	ALLEN HEAD SETSCREW	GA#10-01S	15990	2	61	GREASE CUP INST SHT	6588BD	----	1
27 *	SHAFT KEY	N0407	15990	1	62	FILL PLUG ASSY	48271-066	----	1
28 *	IMPELLER SHAFT	38514-549	15010	1	NOT SHOWN:				
29	BEARING SHIM SET	48261-009	----	1		LUBRICATION DECAL	38816-079	----	1
30	BEARING RETAINER	38322-521	26000	1		INSTRUCTION TAG	38817-011	----	1
31	SIGHT GAUGE	26714-011	----	1		INSTRUCTION TAG	38817-028	----	1
32	PIPE PLUG	P06	15079	1	OPTIONAL:				
33	PEDESTAL DRAIN PLUG	P06	15079	1		METRIC FLANGE KIT	48213-074	----	1
34	STUD	C0608	15991	8		-SUCTION FLANGE	38642-212	10000	1
35	HEX NUT	D06	15991	8		-DISCHAGE FLANGE	38647-401	10000	1

* INDICATES PARTS RECOMMENDED FOR STOCK

PUMP AND SEAL DISASSEMBLY AND REASSEMBLY

Review all SAFETY information in Section A.

Follow the instructions on all tags, label and decals attached to the pump.

This pump requires little service due to its rugged, minimum-maintenance design. However, if it becomes necessary to inspect or replace the wearing parts, follow these instructions which are keyed to Figure 1 and the accompanying parts list.

Before attempting to service the pump, lock out or disconnect the power source to ensure that it will remain inoperative. Close all valves in the suction and discharge lines.

For power source disassembly and repair, consult the literature supplied with the power source, or contact your local power source representative.



Before attempting to open or service the pump:

1. Familiarize yourself with this manual.
2. Lock out or disconnect the power source to ensure that the pump will remain inoperative.
3. Allow the pump to completely cool if overheated.
4. Check the temperature before opening any covers, plates, or plugs.
5. Close the suction and discharge valves.
6. Vent the pump slowly and cautiously.
7. Drain the pump.



Death or serious personal injury and damage to the pump or components can occur if proper lifting procedures are not observed. Make certain that hoists, chains, slings or cables are in

good working condition and of sufficient capacity and that they are positioned so that loads will be balanced and the pump or components will not be damaged when lifting. Suction and discharge hoses and piping must be removed from the pump before lifting. Lift the pump or component only as high as necessary and keep personnel away from suspended objects.

Suction Check Valve Disassembly

Before attempting to service the pump, remove the pump casing drain plug (44) and drain the pump. Clean and reinstall the drain plug.

To service the suction check valve, remove the suction piping. Remove the nuts (56) securing the suction flange (54) and the check valve assembly (47) to the pump casing (1). Pull the check valve assembly from the suction port.

Inspect the check valve parts for wear or damage. If replacement is required, remove the hardware (51 and 52) and separate the check valve gasket (48) and weights (49 and 50).

If no further disassembly is required, see **Suction Check Valve Installation**.

Pump Casing Removal

To service the impeller (2), wear plate assembly (38) or seal assembly (3), disconnect the discharge piping. Remove the hardware securing the pump casing (1) to the base.

Remove the nuts (35) securing the pump casing and gasket set (37) to the pedestal (20) and seal plate (36). Install a standard 5/8-11 UNC lifting eye in the tapped hole in the top of the pump casing. **Be sure** to screw the eye into the casing until fully engaged. Use a hoist and sling of suitable capacity to separate the casing from the seal plate and pedestal.



Do not attempt to lift the complete pump unit using the lifting eye. It is designed to facilitate removal or installation of in-

dividual components only. Additional weight may result in damage to the pump or failure of the eye bolt.

Remove the gasket set from the pedestal and seal plate. Tie and tag the gaskets, or measure and record their thickness for ease of reassembly. Tie and tag any leveling shims used under the casing mounting feet to ease reassembly.

Inspect the wear plate assembly and replace it if badly scored or worn. To remove the wear plate assembly, remove the capscrew (46) and fiber washer (45) just below the suction port. Reach through the suction port and disengage the hardware (59 and 60) from the wear plate stud. Tap the wear plate assembly free of the casing.

Impeller Removal

Immobilize the impeller by wedging a block wood between the vanes. Remove the hardware (39, 40 and 41) securing the impeller to the shaft. If removed, install the shaft key (27). Install a lathe dog on the drive end of the shaft (28) with the “V” notch positioned over the shaft keyway.

With the impeller rotation still blocked, strike the lathe dog sharply in a counterclockwise direction (when facing the drive end of the shaft). The impeller may also be loosened by using a long piece of heavy bar stock to pry against the arm of the lathe dog in a counterclockwise direction (when facing the drive end of the shaft) as shown in Figure 2. **Use caution** not to damage the shaft or keyway. When the impeller breaks loose, remove the lathe dog and wood block and unscrew the impeller from the shaft.

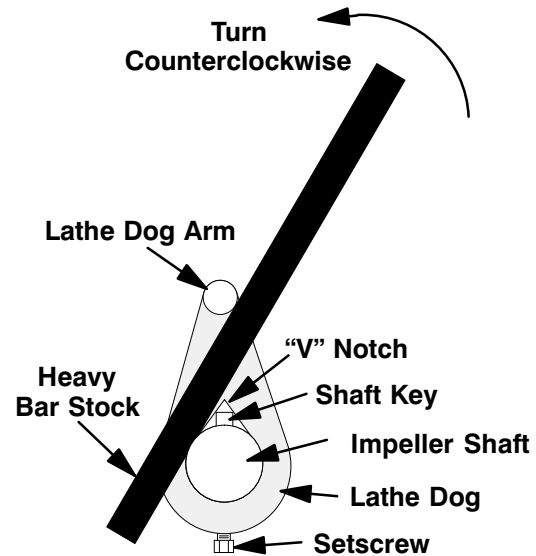

Figure 2. Loosening Impeller

Unscrew the impeller from the shaft. Use caution when removing the impeller; tension on the seal spring will be released as the impeller is unscrewed.

Inspect the impeller and replace it if cracked or badly worn. Slide the impeller adjusting shims (11) off the impeller shaft. Tie and tag the shims, or measure and record their thickness for ease of reassembly.

Seal Removal (Figures 1 and 3)

Make certain that the cross arm on the grease cup has been turned down against the cover before removing the seal assembly.

For ease of disassembly, the seal and seal plate (36) may be removed as a single unit. Before attempting to remove the seal plate, remove the seal cavity grease cup and piping (12, 13 and 14).

Slide the seal plate and seal parts off the shaft as a unit. **Be careful** not to drop or damage any seal parts.

Carefully remove the stationary and rotating seal elements, packing rings, seal spring, and spacer sleeve from the seal plate. Use a stiff wire with a hooked end if necessary.

Inspect the seal liner (15) for wear or grooves that could cause leakage or damage to the seal packing rings. The seal liner is a press fit in the seal plate

(36) and does not normally require replacement. If replacement is required, see **Seal Installation**.

Shaft And Bearing Removal And Disassembly

When the pump is properly operated and maintained, the pedestal should not require disassembly. Disassemble the shaft and bearings **only** when there is evidence of wear or damage.

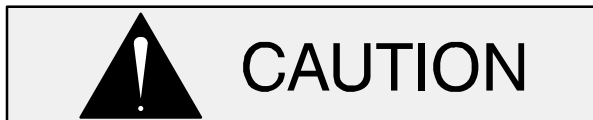

Shaft and bearing disassembly in the field is not recommended. These operations should be performed only in a properly equipped shop by qualified personnel.

Remove the pedestal drain plug (33) and drain the pedestal. Clean and reinstall the plug.

Remove the slinger ring (16) from the shaft. Remove the pedestal mounting hardware from the base. Tie and tag any shims used under the mounting feet for leveling.

Use snap ring pliers to remove the bearing retaining ring (24) from the pedestal bore. Remove the bearing shim set (29); tie and tag the shims, or measure and record their thickness for ease of reassembly.

Remove the setscrews (26) from the bearing retainer (30) and install two machine screws (#10–32 X 1–inch long, not supplied). Pry the retainer from the pedestal bore using a pair of screwdrivers against the heads of the machine screws. **Do not** use the machine screws to jack against the ball bearing. Remove the machine screws and reinstall the setscrews.

Press the oil seal (25) from the bearing retainer, and remove the O-ring (23) from the pedestal bore.

Place a block of wood against the impeller end of the shaft and tap the shaft and assembled bearings (18 and 22) out of the pedestal.

Press the oil seal (17) from the pedestal bore.

After removing the shaft and bearings, clean and inspect the bearings **in place** as follows.



To prevent damage during removal from the shaft, it is recommended that bearings be cleaned and inspected **in place**. It is **strongly** recommended that the bearings be replaced **any** time the shaft and bearings are removed.

Clean the pedestal, shaft and all component parts (except the bearings) with a soft cloth soaked in cleaning solvent. Inspect the parts for wear or damage and replace as necessary.



Most cleaning solvents are toxic and flammable. Use them only in a well-ventilated area free from excessive heat, sparks, and flame. Read and follow all precautions printed on solvent containers.

Inspect the shaft for distortion, nicks or scratches, or thread damage on the impeller end. Dress small nicks and burrs with a fine file or emery cloth. Replace the shaft if defective.

Clean the bearings thoroughly in **fresh** cleaning solvent. Dry the bearings with filtered compressed air and coat with light oil.



Bearings must be kept free of all dirt and foreign material. Failure to do so will greatly shorten bearing life. **Do not** spin dry bearings. This may scratch the balls or races and cause premature bearing failure.

Rotate the bearings by hand to check for roughness or binding and inspect the bearing balls. If rotation is rough or the bearing balls are discolored, replace the bearings.

The bearing tolerances provide a tight press fit onto the shaft and a snug slip fit into the pedestal. Replace the bearings, shaft, or pedestal if the proper bearing fit is not achieved.

If bearing replacement is required, use a bearing puller to remove the inboard and outboard bearings from the impeller shaft.

Shaft And Bearing Reassembly And Installation

Clean and inspect the bearings (18 and 22) as indicated in **Shaft and Bearing Removal and Disassembly**.

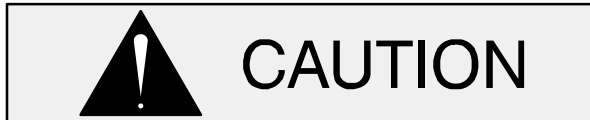

To prevent damage during removal from the shaft, it is recommended that bearings be cleaned and inspected **in place**. It is **strongly** recommended that the bearings be replaced **any** time the shaft and bearings are removed.

The bearings may be heated to ease installation. An induction heater, hot oil bath, electric oven, or hot plate may be used to heat the bearings. Bearings should **never** be heated with a direct flame or directly on a hot plate.

NOTE

*If a hot oil bath is used to heat the bearings, both the oil and the container must be **absolutely** clean. If the oil has been previously used, it must be **thoroughly** filtered.*

Heat the bearings to a uniform temperature **no higher than** 250°F (120°C), and slide the bearings onto the shaft (28), one at a time, until they are fully seated. This should be done quickly, in one continuous motion, to prevent the bearings from cooling and sticking on the shaft.



Use caution when handling hot bearings to prevent burns.

After the bearings have been installed and allowed to cool, check to ensure that they have not moved out of position in shrinking. If movement has occurred, use a suitable sized sleeve and a press to reposition the bearings.

If heating the bearings is not practical, use a suitable sized sleeve and an arbor (or hydraulic) press to install the bearings on the shaft.



When installing the bearings onto the shaft, **never** press or hit against the outer race, balls, or ball cage. Press **only** on the inner race.

Slide the shaft and assembled bearings into the pedestal until the inboard bearing is fully seated against the bore shoulder.



When installing the shaft and bearings into the bearing bore, push against the outer race. **Never** hit the balls or ball cage.

Press the oil seal (17) into the pedestal bore until fully seated with the lip positioned as shown in Figure 1.

Press the oil seal (25) into the bearing retainer (30) with the lip positioned as shown in Figure 1. Replace the bearing retainer O-ring (23) in the pedestal, and lubricate it with grease. Press the bearing retainer into the pedestal until it seats against the bearing. Be careful not to cut the oil seal lip on the shaft keyway. **Be sure** the setscrews (26) in the bearing retainer are positioned horizontally inline.

Install the same thickness of bearing adjusting shims (29) as previously removed. Reinstall the retaining ring (24) and check shaft endplay.

NOTE

Shaft endplay should be .002 to .010 inch (0,05 to 0,25 mm). Add or remove bearing adjusting shims to obtain this endplay.

Install the slinger ring (16) and shaft key (27). Install any leveling shims used under the pedestal feet. Secure the pedestal to the base using the mounting hardware.

Seal Reassembly and Installation

(Figures 1 and 3)

Clean the seal cavity and shaft with a cloth soaked in fresh cleaning solvent.



WARNING!

Most cleaning solvents are toxic and flammable. Use them only in a well-ventilated area free from excessive heat, sparks, and flame. Read and follow all precautions printed on solvent containers.

The seal is not normally reused because wear patterns on the finished faces cannot be realigned during reassembly. This could result in premature failure. If necessary to reuse an old seal in an emergency, **carefully** wash all metallic parts in fresh cleaning solvent and allow to dry thoroughly.

Handle the seal parts with extreme care to prevent damage. Be careful not to contaminate precision finished faces; even fingerprints on the faces can shorten seal life. If necessary, clean the faces with a non-oil based solvent and a clean, lint-free tissue. Wipe **lightly** in a concentric pattern to avoid scratching the faces.

Inspect the seal components for wear, scoring, grooves, and other damage that might cause leakage. Clean and polish the shaft sleeve, or replace it if there are nicks or cuts on either end. If any components are worn, replace the complete seal; **never mix old and new seal parts.**

If a replacement seal is being used, remove it from the container and inspect the precision finished faces to ensure that they are free of any foreign matter.

To ease installation of the seal, lubricate the shaft sleeve, packing rings and seal liner with water or a very **small** amount of oil, and apply a drop of light lubricating oil on the finished faces. Assemble the seal as follows, (see Figure 3).

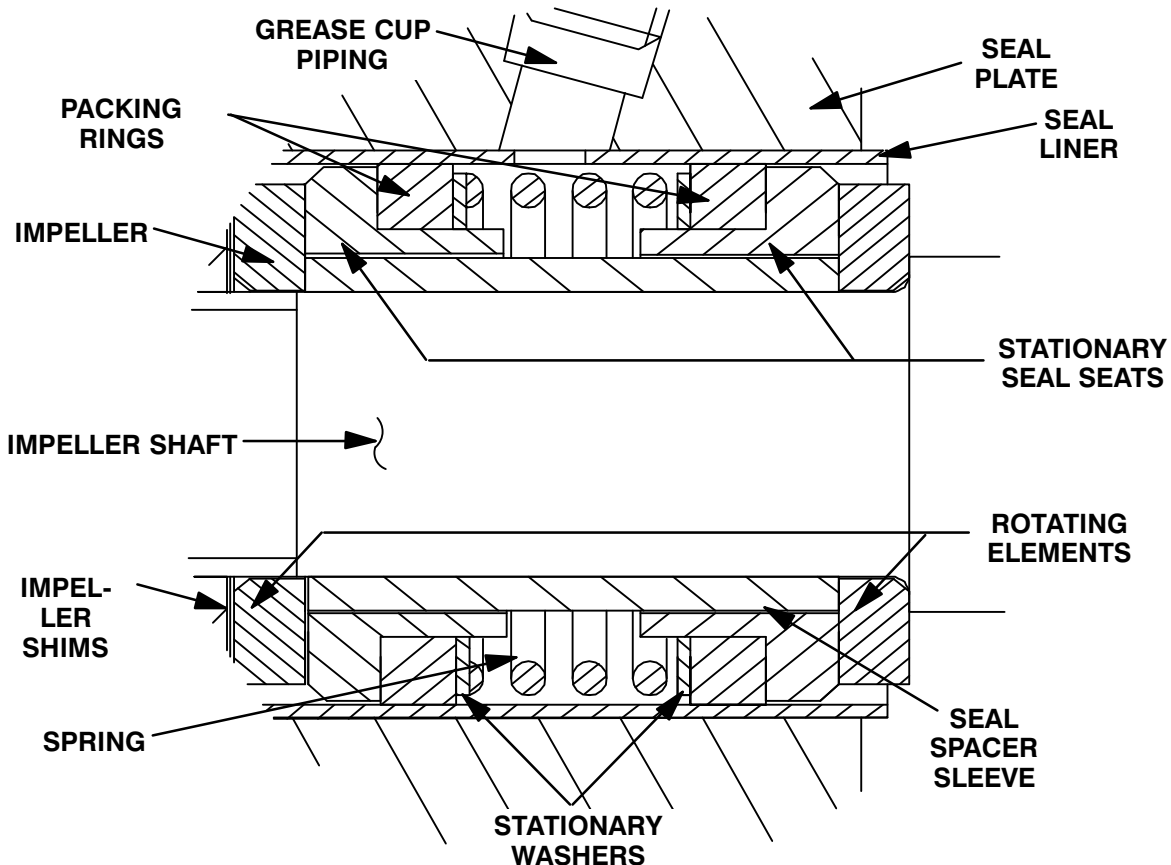

Figure 3. 25284-951 Seal Assembly



This seal is not designed for operation at temperatures above 110°F (43°C). Do not use at higher operating temperatures.

Inspect the seal plate (36), seal liner (15) and the impeller shaft for burrs or sharp corners, and remove any that exist. Replace the seal liner if wear or grooves exist which could cause leakage or damage to the seal packing rings. To replace the seal liner, position the seal plate on the bed of an arbor (or hydraulic) press, and use a new sleeve to force the old one out. After the new liner is properly installed, a 1/4-inch (6,4 mm) diameter hole must be drilled through it to permit the flow of lubricant to the seal assembly. **Be careful** to center the drill in the threaded grease pipe hole and not damage the threads. Deburr the hole from the inside of the seal liner after drilling.

Slide the seal plate and gasket (37) onto the shaft until fully seated against the pedestal (20). Align the threaded seal lubricant hole with the pedestal opening, and temporarily secure the seal plate to the pedestal with three capscrews (3/8—16 UNC x 1—1/2 inch long, not supplied) and nuts.

Position the inboard rotating element on the shaft with the chamfered side facing away from the impeller end of the shaft, and slide it onto the shaft until fully seated against the shaft shoulder.

Subassemble the inboard stationary seat, packing ring and spring washer. Press this subassembly into the lubricated seal liner. A push tube cut from a length of plastic pipe would aid this installation. The O.D. of the pipe should be approximately the same diameter as the O.D. of the seal spring.

Install the spacer sleeve and spring.

Subassemble the outboard stationary seat, packing ring and spring washer. Press this subassembly into the lubricated seal liner. Install the outboard rotating element with the chamfered side facing the impeller.

Reinstall the automatic grease cup and piping (12, 13 and 14) in the seal plate. Lubricate the seal as

indicated in **LUBRICATION**, after the impeller has been installed.

Impeller Installation

Inspect the impeller, and replace it if cracked or badly worn. Install the same thickness of impeller shims (11) as previously removed, and screw the impeller onto the shaft until tight.

A clearance of .010 to .020 inch (0,25 to 0,51 mm) between the impeller and the seal plate is necessary for maximum pump efficiency. Measure this clearance and add or remove impeller shims until this clearance is reached.

NOTE

Be sure the seal plate is tight against the pedestal while measuring this clearance.

After the back clearance is set, secure the impeller with the hardware (39, 40 and 41).

Pump Casing Installation

If the wear plate assembly (38) was removed, position the replacement wear plate assembly squarely against the casing shoulder and secure it with the mounting hardware (45, 46, 59 and 60). Replace the fiber washer (45) if badly worn or compressed.

Remove the hardware temporarily securing the seal plate to the pedestal. Install the same thickness of pump casing gaskets (37) as previously removed. Secure the pump casing (1) to the seal plate and pedestal with the nuts (35).

A clearance of .008 to .015 inch (0,20 to 0,38 mm) between the impeller and the wear plate is also recommended for maximum pump efficiency. Set this clearance by adding or removing gaskets in the pump casing gasket set (37) until the impeller scrapes against the wear plate when the shaft is turned by hand. After the impeller scrapes, add approximately .008 inch (0,20 mm) of gaskets.

Secure the pump casing to the base with the previously removed hardware. Be sure to reinstall any leveling shims used under the mounting feet of the pump casing.

If a lifting eye was used to move the pump casing, **be sure** to remove the lifting eye from the pump casing.



Do not attempt to lift the complete pump unit using the lifting eye. It is designed to facilitate removal or installation of individual components only. Additional weight may result in damage to the pump or failure of the eye bolt.

Suction Check Valve Installation

Inspect components of the check valve assembly (47) and replace as required. If separated at disassembly, assemble the check valve weights (49 and 50) to the check valve gasket (48) with the hardware (51 and 52).

Position the check valve assembly in the suction port with the large weight (49) facing toward the inside of the pump casing. Install the suction flange (54) and secure with the nuts (56). Check the operation of the check valve to ensure proper seating and free movement.

Final Pump Assembly

Be sure the pump and power source are securely mounted to the base. Reconnect the power source to the pump.

Install the suction and discharge lines and open all valves. Make certain that all piping connections are tight, properly supported and secure.

If a lifting eye was used to move the pump casing, **be sure** to remove the lifting eye from the pump casing.

Be sure the pump and power source have been properly lubricated, see **LUBRICATION**.

Remove one of the fill plugs (8 or 62) and fill the pump casing with clean liquid. Reinstall the fill plug and tighten it.

Refer to **OPERATION**, Section C, before putting the pump back into service.

LUBRICATION

Seal Assembly

Fill the grease cup (12) through the grease fitting with No. 2 lithium base grease until grease escapes from the relief hole. Turn the grease cup arm counterclockwise until it is at the top of the stem; this will release the spring to apply grease to the seal (see Figure 4).

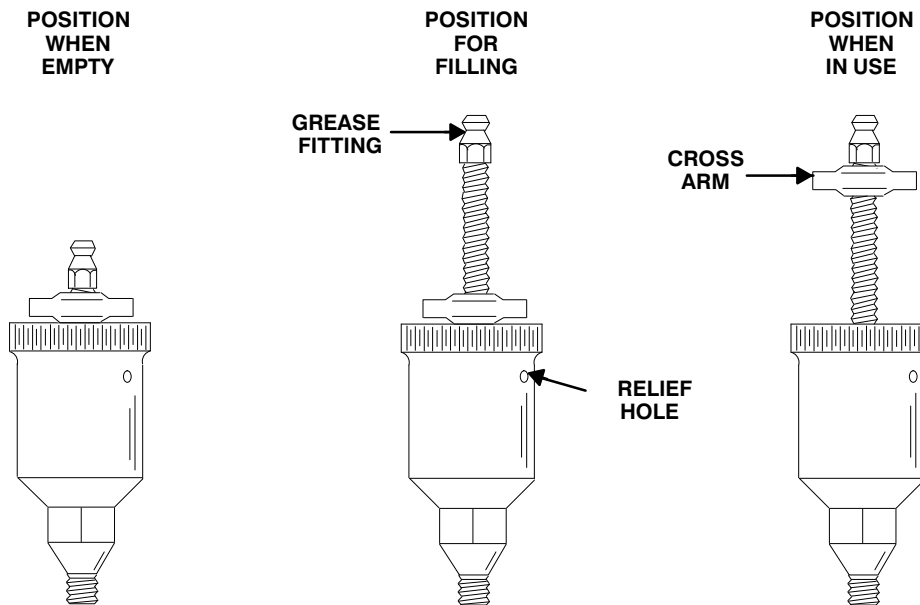
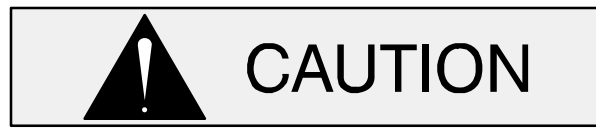

Figure 4. Automatic Lubricating Grease Cup

Bearings

The pedestal was fully lubricated when shipped from the factory. Check the oil level regularly through the sight gauge (31) and maintain it at the middle of the gauge. When lubrication is required, add SAE No. 30 non-detergent oil through the hole for the air vent (19). **Do not** over-lubricate. Over-lubrication can cause the bearings to over-heat, resulting in premature bearing failure.

Under normal conditions, change the oil each 5000 hours or once each year, more frequently if the pump is operated continuously or installed in an environment with rapid temperature change.



Monitor the condition of the bearing lubricant regularly for evidence of rust or moisture condensation. This is especially important in areas where variable hot and cold temperatures are common.

For cold weather operation, consult the factory or a lubricant supplier for the recommended grade of oil.

Power Source

Consult the literature supplied with the power source, or contact your local power source representative.

**For U.S. and International Warranty Information,
Please Visit www.grpumps.com/warranty
or call:**

**U.S.: 419-755-1280
International: +1-419-755-1352**

**For Canadian Warranty Information,
Please Visit www.grcanada.com/warranty
or call:**

519-631-2870