

**INSTALLATION, OPERATION,
AND MAINTENANCE MANUAL**
WITH PARTS LIST



60 SERIES PUMP

MODEL
612L20-B

GORMAN-RUPP PUMPS

www.grpumps.com

Register your new
Gorman-Rupp pump online at
www.grpumps.com

Valid serial number and e-mail address required.

RECORD YOUR PUMP MODEL AND SERIAL NUMBER

Please record your pump model and serial number in the spaces provided below. Your Gorman-Rupp distributor needs this information when you require parts or service.

Pump Model: _____

Serial Number: _____

TABLE OF CONTENTS

INTRODUCTION	PAGE I – 1
SAFETY - SECTION A	PAGE A – 1
INSTALLATION – SECTION B	PAGE B – 1
Pump Dimensions	PAGE B – 1
PREINSTALLATION INSPECTION	PAGE B – 1
POSITIONING PUMP	PAGE B – 2
Lifting	PAGE B – 2
Mounting	PAGE B – 2
SUCTION AND DISCHARGE PIPING	PAGE B – 2
Materials	PAGE B – 2
Line Configuration	PAGE B – 3
Connections to Pump	PAGE B – 3
Gauges	PAGE B – 3
SUCTION LINES	PAGE B – 3
Fittings	PAGE B – 3
Strainers	PAGE B – 3
Sealing	PAGE B – 3
Suction Lines In Sumps	PAGE B – 3
Suction Line Positioning	PAGE B – 4
DISCHARGE LINES	PAGE B – 4
Siphoning	PAGE B – 4
Valves	PAGE B – 4
ALIGNMENT	PAGE B – 5
Coupled Drives	PAGE B – 5
V-Belt Drives	PAGE B – 6
V-Belt Jack Shaft Drives	PAGE B – 6
OPERATION – SECTION C	PAGE C – 1
PRIMING	PAGE C – 1
Hand-Operated Priming Pump	PAGE C – 1
STARTING	PAGE C – 2
Rotation	PAGE C – 2
OPERATION	PAGE C – 2
Leakage	PAGE C – 2
Liquid Temperature And Overheating	PAGE C – 2
Strainer Check	PAGE C – 2
Pump Vacuum Check	PAGE C – 3
STOPPING	PAGE C – 3
Cold Weather Preservation	PAGE C – 3
BEARING TEMPERATURE CHECK	PAGE C – 3
TROUBLESHOOTING – SECTION D	PAGE D – 1
PREVENTIVE MAINTENANCE	PAGE D – 3

TABLE OF CONTENTS
(continued)

PUMP MAINTENANCE AND REPAIR - SECTION E	PAGE E – 1
STANDARD PERFORMANCE CURVE	PAGE E – 1
PARTS LIST:	
Pump Model	PAGE E – 3
PUMP AND SEAL DISASSEMBLY AND REASSEMBLY	PAGE E – 4
Suction Head And Wear Ring Removal	PAGE E – 4
Pump Casing Removal	PAGE E – 5
Impeller Removal	PAGE E – 5
Seal Removal	PAGE E – 6
Shaft and Bearing Removal and Disassembly	PAGE E – 6
Shaft and Bearing Reassembly and Installation	PAGE E – 7
Seal Reassembly and Installation	PAGE E – 8
Impeller Installation	PAGE E – 10
Pump Casing Installation	PAGE E – 10
Suction Head And Wear Ring Installation	PAGE E – 10
LUBRICATION	PAGE E – 10
Seal Assembly	PAGE E – 10
Bearings	PAGE E – 10
Power Source	PAGE E – 11

INTRODUCTION

Thank You for purchasing a Gorman-Rupp pump. **Read this manual** carefully to learn how to safely install and operate your pump. Failure to do so could result in personal injury or damage to the pump.

This pump is a 60 Series, enclosed impeller, centrifugal model with straight-in suction, without a suction check valve. The pump is designed for handling wastewater, mud or slurries containing specified entrained solids. The basic material of construction for wetted parts is gray iron, with ductile impeller, brass wear rings and a stainless steel impeller shaft.

This manual will alert personnel to known procedures which require special attention, to those which could damage equipment, and to those which could be dangerous to personnel. However, this manual cannot possibly anticipate and provide detailed precautions for every situation that might occur during maintenance of the unit. Therefore, it is the responsibility of the owner/maintenance personnel to ensure that **only** safe, established maintenance procedures are used, and that any procedures not addressed in this manual are performed **only** after establishing that neither personal safety nor pump integrity are compromised by such practices.

For information or technical assistance on the power source, contact the power source manufacturer's local dealer or representative.

If there are any questions regarding the pump or its application which are not covered in this manual or in other literature accompanying this unit, please contact your Gorman-Rupp distributor, or:

The Gorman-Rupp Company
P.O. Box 1217
Mansfield, Ohio 44901-1217
Phone: (419) 755-1011
 or:
Gorman-Rupp of Canada Limited
70 Burwell Road
St. Thomas, Ontario N5P 3R7
Phone: (519) 631-2870

The following are used to alert maintenance personnel to procedures which require special attention, to those which could damage equipment, and to those which could be dangerous to personnel:



Immediate hazards which WILL result in severe personal injury or death. These instructions describe the procedure required and the injury which will result from failure to follow the procedure.



Hazards or unsafe practices which COULD result in severe personal injury or death. These instructions describe the procedure required and the injury which could result from failure to follow the procedure.



Hazards or unsafe practices which COULD result in minor personal injury or product or property damage. These instructions describe the requirements and the possible damage which could result from failure to follow the procedure.

NOTE

Instructions to aid in installation, operation, and maintenance or which clarify a procedure.

SAFETY - SECTION A

This information applies to 60 Series basic pumps. Gorman-Rupp has no control over or particular knowledge of the power source which will be used. Refer to the manual accompanying the power source before attempting to begin operation.

Because pump installations are seldom identical, this manual cannot possibly provide detailed instructions and precautions for each specific application. Therefore, it is the owner/installer's responsibility to ensure that applications not addressed in this manual are performed only after establishing that neither operator safety nor pump integrity are compromised by the installation.



Before attempting to open or service the pump:

1. Familiarize yourself with this manual.
2. Disconnect or lock out the power source to ensure that the pump will remain inoperative.
3. Allow the pump to completely cool if overheated.
4. Check the temperature before opening any covers, plates, or plugs.
5. Close the suction and discharge valves.
6. Vent the pump slowly and cautiously.
7. Drain the pump.



This pump is designed to handle wastewater, mud or slurries containing specified entrained solids. Do not attempt to pump volatile, corrosive or flammable

liquids which may damage the pump or endanger personnel as a result of pump failure.



Death or serious personal injury and damage to the pump or components can occur if proper lifting procedures are not observed. Make certain that hoists, chains, slings or cables are in good working condition and of sufficient capacity and that they are positioned so that loads will be balanced and the pump or components will not be damaged when lifting. Suction and discharge hoses and piping must be removed from the pump before lifting. Lift the pump or component only as high as necessary and keep personnel away from suspended objects.



After the pump has been positioned, make certain that the pump and all piping or hose connections are tight, properly supported and secure before operation.



Do not operate the pump against a closed discharge valve for long periods of time. If operated against a closed discharge valve, pump components will deteriorate, and the liquid could come to a boil, build pressure, and cause the pump casing to rupture or explode.



Do not remove plates, covers, gauges, pipe plugs, or fittings from an over-

heated pump. Vapor pressure within the pump can cause parts being disengaged to be ejected with great force. Allow the pump to cool before servicing.



Do not operate the pump without shields and/or guards in place over the drive shafts, belts, and/or couplings, or

other rotating parts. Exposed rotating parts can catch clothing, fingers, or tools, causing severe injury to personnel.



Pumps and related equipment must be installed and operated according to all national, local and industry standards.

INSTALLATION – SECTION B

Review all SAFETY information in Section A.

Since pump installations are seldom identical, this section offers only general recommendations and practices required to inspect, position, and arrange the pump and piping.

Most of the information pertains to a standard **static lift** application where the pump is positioned above the free level of liquid to be pumped.

If installed in a **flooded suction application** where the liquid is supplied to the pump under pressure, some of the information such as mounting, line configuration, and priming must be tailored to the

specific application. Since the pressure supplied to the pump is critical to performance and safety, **be sure** to limit the incoming pressure to 50% of the maximum permissible operating pressure as shown on the pump performance curve (see Section E, Page 1).

For further assistance, contact your Gorman-Rupp distributor or the Gorman-Rupp Company.

Pump Dimensions

See Figure B-1 for the approximate physical dimensions of this pump.

OUTLINE DRAWING

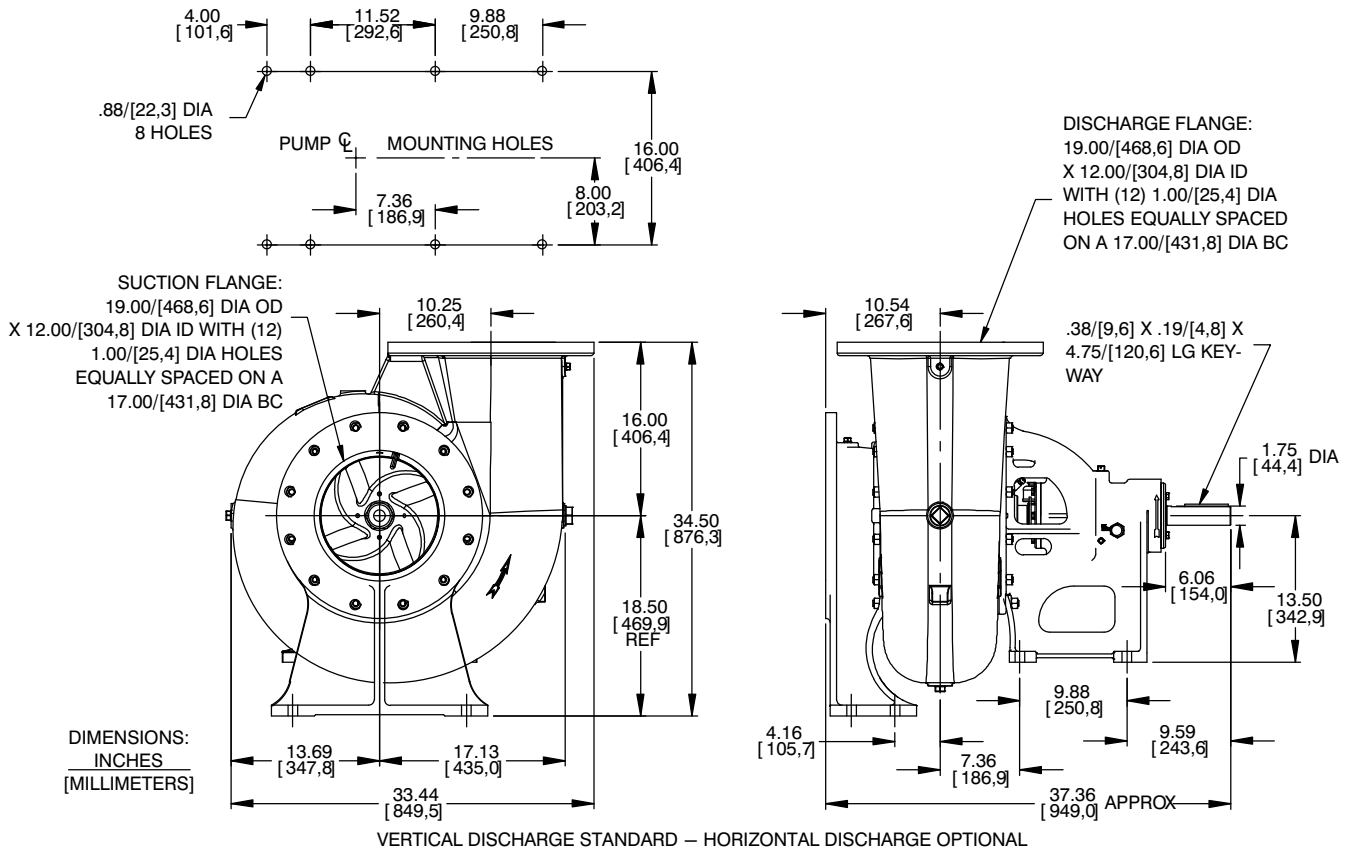

Figure B-1. Pump Model 612L20-B

PREINSTALLATION INSPECTION

The pump assembly was inspected and tested before shipment from the factory. Before installation, inspect the pump for damage which may have occurred during shipment. Check as follows:

- a. Inspect the pump for cracks, dents, damaged threads, and other obvious damage.
- b. Check for and tighten loose attaching hardware. Since gaskets tend to shrink after dry-

ing, check for loose hardware at mating surfaces.

- c. Carefully read all tags, decals, and markings on the pump assembly, and perform all duties indicated. Note that the pump shaft rotates in the required direction.



Only operate this pump in the direction indicated by the arrow on the pump body and on the accompanying decal. Otherwise, the impeller could become loosened from the shaft and seriously damage the pump.

- d. Check levels and lubricate as necessary. Refer to **LUBRICATION** in the **MAINTENANCE AND REPAIR** section of this manual and perform duties as instructed.
- e. If the pump has been stored for more than 12 months, some of the components or lubricants may have exceeded their maximum shelf life. These **must be inspected or replaced** to ensure maximum pump service.

If the maximum shelf life has been exceeded, or if anything appears to be abnormal, contact your Gorman-Rupp distributor or the factory to determine the repair or updating policy. **Do not** put the pump into service until appropriate action has been taken.

POSITIONING PUMP

Lifting



Death or serious personal injury and damage to the pump or components can occur if proper lifting procedures are not observed. Make certain that hoists, chains, slings or cables are in good working condition and of sufficient capacity and that they are posi-

tioned so that loads will be balanced and the pump or components will not be damaged when lifting. Suction and discharge hoses and piping must be removed from the pump before lifting. Lift the pump or component only as high as necessary and keep personnel away from suspended objects.

Pump unit weights will vary depending on the mounting and drive provided. Check the shipping tag on the unit packaging for the actual weight, and use lifting equipment with appropriate capacity. Drain the pump and remove all customer-installed equipment such as suction and discharge hoses or piping before attempting to lift existing, installed units.



The pump assembly can be seriously damaged if the chains or cables used to lift and move the unit are improperly wrapped around the pump.

Mounting

Locate the pump in an accessible place as close as practical to the liquid being pumped. Level mounting is essential for proper operation.

The pump may have to be supported or shimmed to provide for level operation or to eliminate vibration.

SUCTION AND DISCHARGE PIPING

Pump performance is adversely effected by increased suction lift, discharge elevation, and friction losses. See the performance curve on Page E-1 to be sure your overall application allows pump to operate within the safe operation range.

Materials

Either pipe or hose maybe used for suction and discharge lines; however, the materials must be compatible with the liquid being pumped. If hose is used in suction lines, it must be the rigid-wall, reinforced type to prevent collapse under suction. Using piping couplings in suction lines is not recommended.

Line Configuration

Keep suction and discharge lines as straight as possible to minimize friction losses. Make minimum use of elbows and fittings, which substantially increase friction loss. If elbows are necessary, use the long-radius type to minimize friction loss.

Connections to Pump

Before tightening a connecting flange, align it exactly with the pump port. Never pull a pipe line into place by tightening the flange bolts and/or couplings.

Lines near the pump must be independently supported to avoid strain on the pump which could cause excessive vibration, decreased bearing life, and increased shaft and seal wear. If hose-type lines are used, they should have adequate support to secure them when filled with liquid and under pressure.

Gauges

Most pumps are drilled and tapped for installing discharge pressure and vacuum suction gauges. If these gauges are desired for pumps that are not tapped, drill and tap the suction and discharge lines not less than 18 inches (457,2 mm) from the suction and discharge ports and install the lines. Installation closer to the pump may result in erratic readings.

SUCTION LINES

To avoid air pockets which could affect pump priming, the suction line must be as short and direct as possible. When operation involves a suction lift, the line must always slope upward to the pump from the source of the liquid being pumped; if the line slopes down to the pump at any point along the suction run, air pockets will be created.

The **maximum** vertical suction lift for this pump is 15 feet. It is not designed to be operated at a higher lift.

Fittings

Suction lines should be the same size as the pump inlet. If reducers are used in suction lines, they should be the eccentric type, and should be installed with the flat part of the reducers uppermost to avoid creating air pockets. Valves are not normally used in suction lines, but if a valve is used, install it with the stem horizontal to avoid air pockets.

Strainers

A strainer or other device should be used to filter solids larger than the pump's capacity to avoid damage or decreased performance. Information about solids size handling can be found on the performance curve for your specific pump. When selecting or installing a strainer, make certain that the total area of the openings in the strainer is at least three or four times the cross section of the suction line, and the openings will not permit passage of solids larger than the solids handling capability of the pump.

Sealing

Since even a slight leak will affect priming, head, and capacity, especially when operating with a high suction lift, all connections in the suction line should be sealed with pipe dope to ensure an airtight seal. Follow the sealant manufacturer's recommendations when selecting and applying the pipe dope. The pipe dope should be compatible with the liquid being pumped.

Suction Lines In Sumps

If a single suction line is installed in a sump, it should be positioned away from the wall of the sump at a distance equal to 1–1/2 times the diameter of the suction line.

If there is a liquid flow from an open pipe into the sump, the flow should be kept away from the suction inlet because the inflow will carry air down into the sump, and air entering the suction line will reduce pump efficiency.

If it is necessary to position inflow close to the suction inlet, install a baffle between the inflow and the suction inlet at a distance 1–1/2 times the diame-

ter of the suction pipe. The baffle will allow entrained air to escape from the liquid before it is drawn into the suction inlet.

If two suction lines are installed in a single sump, the flow paths may interact, reducing the efficiency of one or both pumps. To avoid this, position the suction inlets so that they are separated by a distance equal to at least 3 times the diameter of the suction pipe.

Suction Line Positioning

The depth of submergence of the suction line is critical to efficient pump operation. Figure B-2

shows recommended minimum submergence vs. velocity.

NOTE

The pipe submergence required may be reduced by installing a standard pipe increaser fitting at the end of the suction line. The larger opening size will reduce the inlet velocity. Calculate the required submergence using the following formula based on the increased opening size (area or diameter).

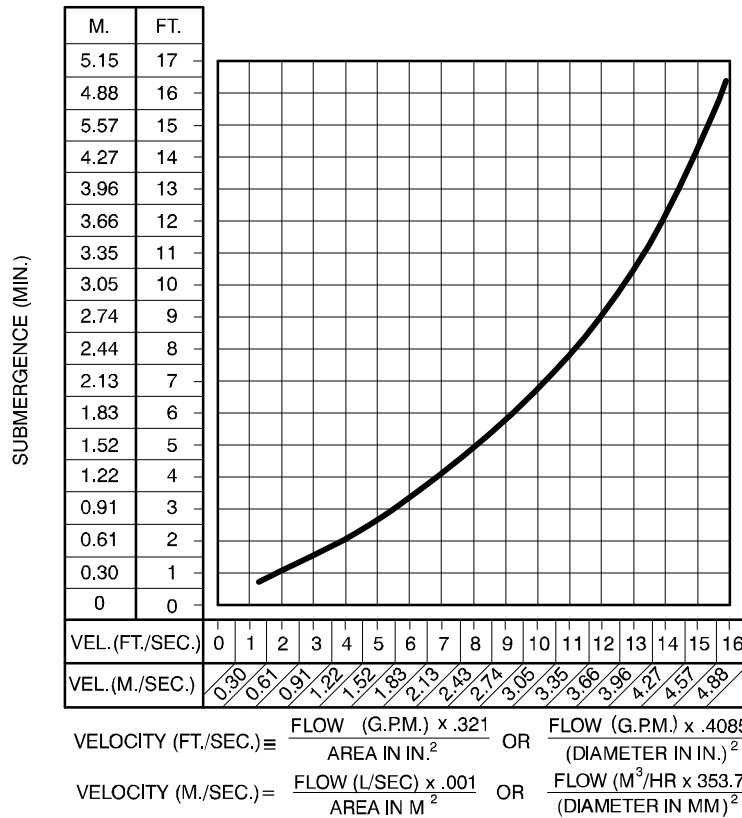

Figure B-2. Recommended Minimum Suction Line Submergence vs. Velocity

DISCHARGE LINES

Siphoning

Do not terminate the discharge line at a level lower than that of the liquid being pumped unless a siphon breaker is used in the line. Otherwise, a siphoning action causing damage to the pump could result.

Valves

If a throttling valve is desired in the discharge line, use a valve as large as the largest pipe to minimize friction losses. Never install a throttling valve in a suction line.

A check valve in the discharge line is normally recommended, but it is not necessary in low discharge head applications.

With high discharge heads, it is recommended that a throttling valve and a system check valve be installed in the discharge line to protect the pump from excessive shock pressure and reverse rotation when it is stopped.

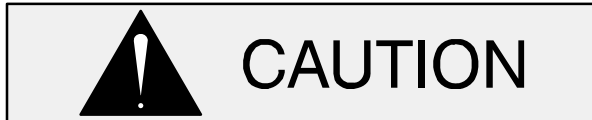

If the application involves a high discharge head, gradually close the discharge throttling valve before stopping the pump.

ALIGNMENT

The alignment of the pump and its power source is critical for trouble-free mechanical operation. In either a flexible coupling or V-belt driven system, the driver and pump must be mounted so that their shafts are aligned with and parallel to each other. It is imperative that alignment be checked after the pump and piping are installed, and before operation.

NOTE

Check **Rotation**, Section C, before final alignment of the pump.

When mounted at the Gorman-Rupp factory, driver and pump are aligned before shipment. Misalignment will occur in transit and handling. Pumps **must** be checked and realigned before operation. Before checking alignment, tighten the foundation bolts. The pump casing feet and/or pedestal feet, and the driver mounting bolts should also be tightly secured.



When checking alignment, disconnect the power source to ensure that the pump will remain inoperative.



Adjusting the alignment in one direction may alter the alignment in another direction. Check each procedure after altering alignment.

Coupled Drives

When using couplings, the axis of the power source must be aligned to the axis of the pump shaft in both the horizontal and vertical planes. Most couplings require a specific gap or clearance between the driving and the driven shafts. Refer to the coupling manufacturer's service literature.

Align spider insert type couplings by using calipers to measure the dimensions on the circumference of the outer ends of the coupling hub every 90°. The coupling is in alignment when the hub ends are the same distance apart at all points (see Figure B—3).

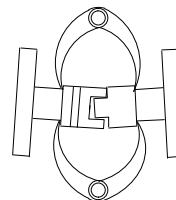

Figure B—3. Aligning Spider-Type Couplings

Align non-spider type couplings by using a feeler gauge or taper gauge between the coupling halves every 90°. The coupling is in alignment when the hubs are the same distance apart at all points (see Figure B—4).

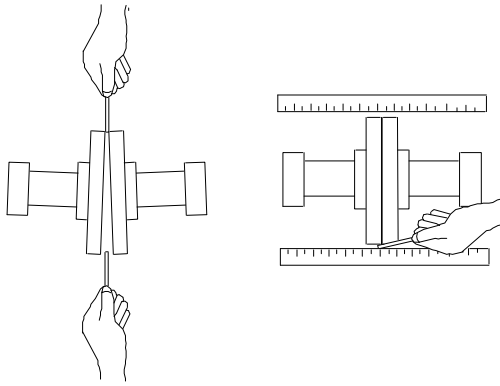
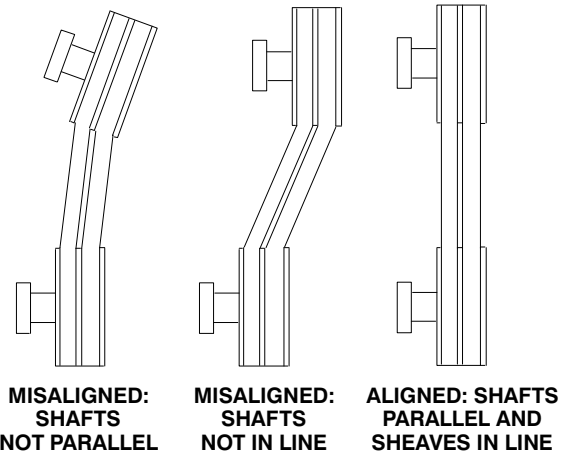

Figure B—4. Aligning Non-Spider-Type Couplings

Check parallel adjustment by laying a straightedge across both coupling rims at the top, bottom, and side. When the straightedge rests evenly on both halves of the coupling, the coupling is in horizontal parallel alignment. If the coupling is misaligned, use a feeler gauge between the coupling and the straightedge to measure the amount of misalignment.

Belt Drives

When using belt drives, the power source and the pump must be parallel. Use a straightedge along the sides of the pulleys to ensure that the pulleys are properly aligned (see Figure B—5). In drive systems using two or more belts, make certain that the belts are a matched set; unmatched sets will cause accelerated belt wear.



MISALIGNED: SHAFTS NOT PARALLEL MISALIGNED: SHAFTS NOT IN LINE ALIGNED: SHAFTS PARALLEL AND SHEAVES IN LINE

Figure B—5. Alignment of V-Belt Driven Pumps

Tighten the belts in accordance with the belt manufacturer’s instructions. If the belts are too loose, they will slip; if the belts are too tight, there will be excessive power loss and possible bearing failure. Select pulleys that will match the proper speed ratio; overspeeding the pump may damage both pump and power source.



WARNING!

Do not operate the pump without the guard in place over the rotating parts. Exposed rotating parts can catch clothing, fingers, or tools, causing severe injury to personnel.

V-Belt Jack Shaft Drives

If the pump is to be driven at speeds exceeding 1050 rpm, the V-belts must operate through a jack shaft arrangement to protect the shaft bearings from excessive stress. Failure to use a jack shaft on high speed applications will result in premature shaft bearing failure.

OPERATION – SECTION C

Review all **SAFETY** information in Section A.

Follow the instructions on all tags, labels and decals attached to the pump.



This pump is designed to handle wastewater, mud or slurries containing specified entrained solids. Do not attempt to pump volatile, corrosive or flammable liquids which may damage the pump or endanger personnel as a result of pump failure.

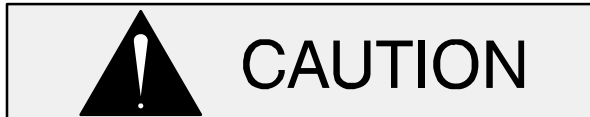

Pump speed and operating condition points must be within the continuous performance range shown on the curve (see Section E, Page 1).

PRIMING

Install the pump and piping as described in **INSTALLATION**. Make sure that the piping connections are tight, and that the pump is securely mounted. Check that the pump is properly lubricated (see **LUBRICATION** in **MAINTENANCE AND REPAIR**).

This pump should never be operated unless there is liquid in the pump casing.



Never operate this pump unless there is liquid in the pump casing. The pump will not prime when dry. extended operation of a dry pump will destroy the seal assembly.

Add liquid to the pump casing when:

1. The pump is being put into service for the first time.

2. The pump has not been used for a considerable length of time.
3. The liquid in the pump casing has evaporated.

Once the pump casing has been filled, the pump will prime and reprime as necessary.



After filling the pump casing, reinstall and tighten the fill plug. Do not attempt to operate the pump unless all connecting piping is securely installed. Otherwise, liquid in the pump forced out under pressure could cause injury to personnel.

Hand-Operated Priming Pump

The hand-operated priming pump (see Figure 1) is designed to draw air out of the suction line and the pump casing.

The hand-operated priming pump can be used while the pump is either stopped or operating.

Close the discharge line check valve (if so equipped) before engaging the priming device.

To prime the pump, open the cock in the bottom of the priming pump. Operate the handle of the pump until all of the air is expelled from the line and a small amount of liquid flows from the drain cock.

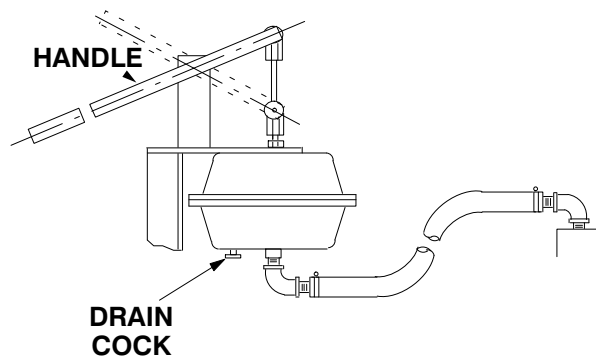

Figure C—1. Hand Primer Assembly

Once the pump is fully primed, close the cock, open the discharge line throttling valve and start the pump.

STARTING

Consult the operations manual furnished with the power source.

Starting procedures will vary slightly depending on the pump application, type of priming device, and type of drive.

Rotation

The correct direction of pump rotation is counter-clockwise when facing the impeller. If the pump is operated in the wrong direction, the impeller could become loosened from the shaft and seriously damage the pump.



The pump must operate in the direction indicated by the arrow on the pump, or accompanying decals.

Consult the operating manual furnished with the pump power source before attempting to start the power source.

If an electric motor is used to drive the pump, remove V-belts, couplings, or otherwise disconnect the pump from the motor before checking motor rotation. Operate the motor independently while observing the direction of the motor shaft, or cooling fan.

If rotation is incorrect on a three-phase motor, have a qualified electrician interchange any two of the three phase wires to change direction. If rotation is incorrect on a single-phase motor, consult the literature supplied with the motor for specific instructions.

OPERATION

Leakage

No leakage should be visible at pump mating surfaces, or at pump connections or fittings. Keep all line connections and fittings tight to maintain maximum pump efficiency.

Liquid Temperature And Overheating

The **maximum** liquid temperature for this pump is 160° F (71° C). Do not apply it at a higher operating temperature.

Overheating can occur if operated with the valves in the suction or discharge lines closed. Operating against closed valves could bring the liquid to a boil, build pressure, and cause the pump to rupture or explode. If overheating occurs, stop the pump and allow it to cool before servicing it. Refill the pump casing with cool liquid.



Allow an over-heated pump to cool before servicing. Do not remove plates, covers, gauges, or fittings from an over-heated pump. Liquid within the pump can reach boiling temperatures, and vapor pressure within the pump can cause parts being disengaged to be ejected with great force. After the pump cools, drain the liquid from the pump by removing the casing drain plug. Use caution when removing the plug to prevent injury to personnel from hot liquid.

Strainer Check

If a suction strainer has been shipped with the pump or installed by the user, check the strainer regularly, and clean it as necessary. The strainer should also be checked if pump flow rate begins to drop. If a vacuum suction gauge has been installed, monitor and record the readings regularly to detect strainer blockage.

Never introduce air or steam pressure into the pump casing or piping to remove a blockage. This could result in personal injury or damage to the equipment. If backflushing is absolutely necessary, **liquid pressure** must be limited to 50% of the maximum permissible operating pressure shown on the pump performance curve (see Section E, Page 1).

Pump Vacuum Check

Since this pump does not have a suction check valve, the discharge line must be fitted with a check valve if a pump vacuum reading is to be taken.

With the pump inoperative, install a vacuum gauge in the system, using pipe dope on the threads. Block the suction line and start the pump. At operating speed the pump should pull a vacuum of 20 inches (508 mm) or more of mercury. If it does not, check for air leaks in the seal, gasket, or discharge valve.

Open the suction line, and read the vacuum gauge with the pump primed and at operating speed. Shut off the pump. The vacuum gauge reading will immediately drop proportionate to static suction lift, and should then stabilize. If the vacuum reading falls off rapidly after stabilization, an air leak exists. Before checking for the source of the leak, check the point of installation of the vacuum gauge.

STOPPING

Never halt the flow of liquid suddenly. If the liquid being pumped is stopped abruptly, damaging shock waves can be transmitted to the pump and piping system. Close all connecting valves slowly.



If the application involves a high discharge head, gradually close the discharge throttling valve before stopping the pump.

After stopping the pump, disconnect the power source or lock it out to ensure that the pump will remain inoperative.

Cold Weather Preservation

In below freezing conditions, drain the pump to prevent damage from freezing. Also, clean out any solids by flushing with a hose. Operate the pump for approximately one minute; this will remove any remaining liquid that could freeze the pump rotating parts. If the pump will be idle for more than a few hours, or if it has been pumping liquids containing a large amount of solids, drain the pump, and flush it thoroughly with clean water. To prevent large solids from clogging the drain port and preventing the pump from completely draining, insert a rod or stiff wire in the drain port, and agitate the liquid during the draining process. Clean out any remaining solids by flushing with a hose.

BEARING TEMPERATURE CHECK

Bearings normally run at higher than ambient temperatures because of heat generated by friction. Temperatures up to 160°F (71°C) are considered normal for bearings, and they can operate safely to at least 180°F (82°C).

Checking bearing temperatures by hand is inaccurate. Bearing temperatures can be measured accurately by placing a contact-type thermometer against the housing. Record this temperature for future reference.

A sudden increase in bearing temperatures is a warning that the bearings are at the point of failing to operate properly. Make certain that the bearing lubricant is of the proper viscosity and at the correct level (see **LUBRICATION** in Section E). Bearing overheating can also be caused by shaft misalignment and/or excessive vibration.

When pumps are first started, the bearings may seem to run at temperatures above normal. Continued operation should bring the temperatures down to normal levels.

TROUBLESHOOTING – SECTION D

Review all SAFETY information in Section A.



Before attempting to open or service the pump:

1. Familiarize yourself with this manual.
2. Lock out or disconnect the power source to ensure that the pump will remain inoperative.
3. Allow the pump to completely cool if overheated.
4. Check the temperature before opening any covers, plates, or plugs.
5. Close the suction and discharge valves.
6. Vent the pump slowly and cautiously.
7. Drain the pump.

TROUBLE	POSSIBLE CAUSE	PROBABLE REMEDY
PUMP FAILS TO PRIME	Air leak in suction line. Lining of suction hose collapsed. Leaking or worn seal or pump gasket. Auxiliary priming device faulty or improperly installed. Suction lift or discharge head too high. Strainer clogged.	Correct leak. Replace suction hose. Check pump vacuum. Replace leaking or worn seal or gasket. Check for and replace defective unit. Check piping installation and install bypass line if needed. See INSTALLATION . Check strainer and clean if necessary.
PUMP STOPS OR FAILS TO DELIVER RATED FLOW OR PRESSURE	Air leak in suction line. Lining of suction hose collapsed. Suction intake not submerged at proper level or sump too small.	Correct leak. Replace suction hose. Check installation and correct submergence as needed.

TROUBLE	POSSIBLE CAUSE	PROBABLE REMEDY
PUMP STOPS OR FAILS TO DELIVER RATED FLOW OR PRESSURE (cont.)	<p>Impeller or other wearing parts worn or damaged.</p> <p>Strainer clogged.</p> <p>Impeller clogged.</p> <p>Discharge head too high.</p> <p>Suction lift too high.</p> <p>Leaking or worn seal or pump gasket.</p> <p>Pump speed too slow.</p>	<p>Replace worn or damaged parts. Check that impeller is properly centered and rotates freely.</p> <p>Check strainer and clean if necessary.</p> <p>Free impeller of debris.</p> <p>Install bypass line.</p> <p>Measure lift w/vacuum gauge. Reduce lift and/or friction losses in suction line.</p> <p>Check pump vacuum. Replace leaking or worn seal or gasket.</p> <p>Check driver output; check belts or couplings for slippage.</p>
PUMP REQUIRES TOO MUCH POWER	<p>Pump speed too high.</p> <p>Discharge head too low.</p> <p>Liquid solution too thick.</p>	<p>Check driver output; check that sheaves or couplings are correctly sized.</p> <p>Adjust discharge valve.</p> <p>Dilute if possible.</p>
PUMP CLOGS FREQUENTLY	<p>Discharge flow too slow.</p> <p>Suction check valve or foot valve clogged or binding.</p>	<p>Open discharge valve fully to increase flow rate, and run engine at maximum governed speed.</p> <p>Clean valve.</p>
EXCESSIVE NOISE	<p>Cavitation in pump.</p> <p>Pumping entrained air.</p> <p>Pump or drive not securely mounted.</p> <p>Impeller clogged or damaged.</p>	<p>Reduce suction lift and/or friction losses in suction line. Record vacuum and pressure gauge readings and consult local representative or factory.</p> <p>Locate and eliminate source of air bubble.</p> <p>Secure mounting hardware.</p> <p>Clean out debris; replace damaged parts.</p>
BEARINGS RUN TOO HOT	<p>Bearing temperature is high, but within limits.</p> <p>Low or incorrect lubricant.</p> <p>Suction and discharge lines not properly supported.</p> <p>Drive misaligned.</p>	<p>Check bearing temperature regularly to monitor any increase.</p> <p>Check for proper type and level of lubricant.</p> <p>Check piping installation for proper support.</p> <p>Align drive properly.</p>

PREVENTIVE MAINTENANCE

Since pump applications are seldom identical, and pump wear is directly affected by such things as the abrasive qualities, pressure and temperature of the liquid being pumped, this section is intended only to provide general recommendations and practices for preventive maintenance. Regardless of the application however, following a routine preventive maintenance schedule will help assure trouble-free performance and long life from your Gorman-Rupp pump. For specific questions concerning your application, contact your Gorman-Rupp distributor or the Gorman-Rupp Company.

Record keeping is an essential component of a good preventive maintenance program. Changes in suction and discharge gauge readings (if so

equipped) between regularly scheduled inspections can indicate problems that can be corrected before system damage or catastrophic failure occurs. The appearance of wearing parts should also be documented at each inspection for comparison as well. Also, if records indicate that a certain part (such as the seal) fails at approximately the same duty cycle, the part can be checked and replaced before failure occurs, reducing unscheduled down time.

For new applications, a first inspection of wearing parts at 250 hours will give insight into the wear rate for your particular application. Subsequent inspections should be performed at the intervals shown on the chart below. Critical applications should be inspected more frequently.

Preventive Maintenance Schedule					
Item	Service Interval*				
	Daily	Weekly	Monthly	Semi-Annually	Annually
General Condition (Temperature, Unusual Noises or Vibrations, Cracks, Leaks, Loose Hardware, Etc.)	I				
Pump Performance (Gauges, Speed, Flow)	I				
Bearing Lubrication		I			R
Seal Lubrication (And Packing Adjustment, If So Equipped)		I			R
V-Belts (If So Equipped)			I		
Air Release Valve Plunger Rod (If So Equipped)			I	C	
Front Impeller Clearance (Wear Plate)				I	
Rear Impeller Clearance (Seal Plate)				I	
Check Valve					I
Pressure Relief Valve (If So Equipped)					C
Pump and Driver Alignment					I
Shaft Deflection					I
Bearings					I
Bearing Housing					I
Piping					I
Driver Lubrication – See Mfgr's Literature					I
Legend: I = Inspect, Clean, Adjust, Repair or Replace as Necessary C = Clean R = Replace * Service interval based on an intermittent duty cycle equal to approximately 4000 hours annually. Adjust schedule as required for lower or higher duty cycles or extreme operating conditions.					

PUMP MAINTENANCE AND REPAIR - SECTION E

MAINTENANCE AND REPAIR OF THE WEARING PARTS OF THE PUMP WILL MAINTAIN PEAK OPERATING PERFORMANCE.

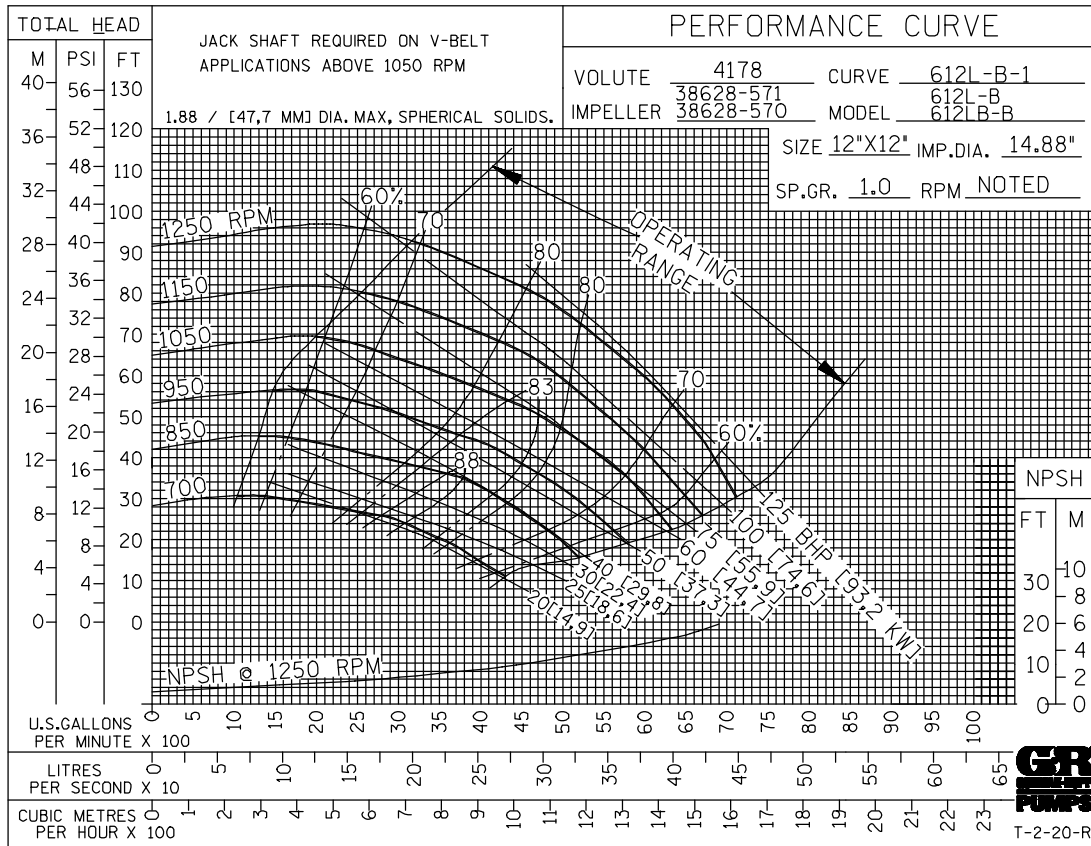

*** STANDARD PERFORMANCE FOR PUMP MODEL 612L20-B**

* Based on 70° F (21° C) clear water at sea level with minimum suction lift. Since pump installations are seldom identical, your performance may be different due to such factors as viscosity, specific gravity, elevation, temperature, and impeller trim.

Contact the Gorman-Rupp Company to verify performance or part numbers.

If your pump serial number is followed by an "N", your pump is **NOT** a standard production model.

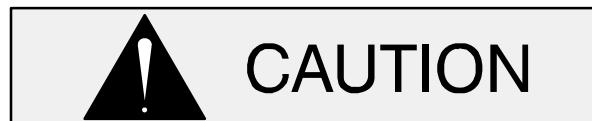

CAUTION
Pump speed and operating condition points must be within the continuous performance range shown on the curve.

ILLUSTRATION

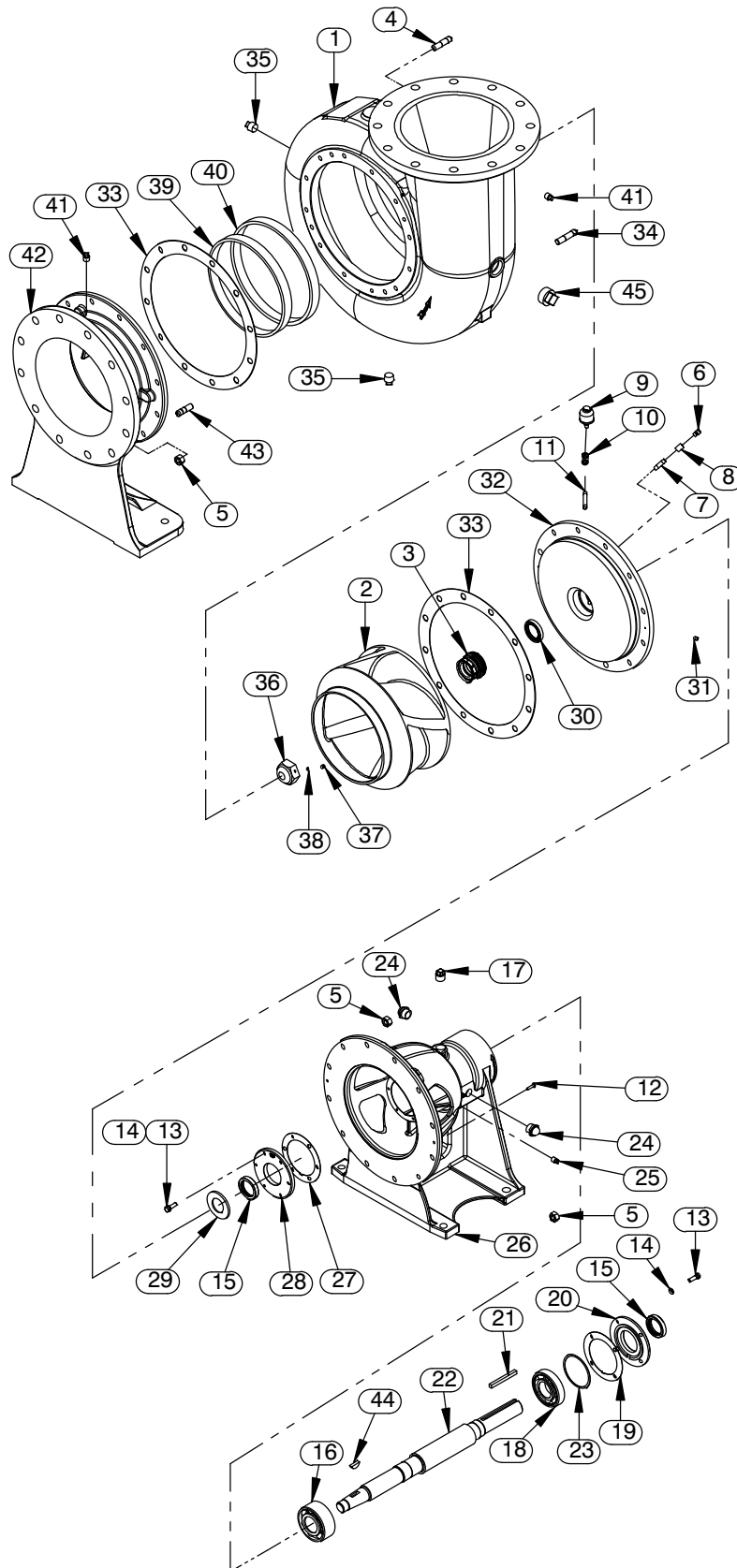

Figure 1. Pump Model 612L20-B

PARTS LIST
Pump Model 612L20-B
 (From S/N 1742090 up)

If your pump serial number is followed by an "N", your pump is **NOT** a standard production model. Contact the Gorman-Rupp Company to verify part numbers.

ITEM NO.	PART NAME	PART NUMBER	QTY	ITEM NO.	PART NAME	PART NUMBER	QTY
1	REPAIR PUMP CASING	SEE NOTE BELOW	1	27 *	BEARING CAP GASKET	4184G 18000	1
2 *	IMPELLER	38628-571 11030	1	28	BEARING CAP	4184A 10010	1
3 *	SEAL ASSEMBLY	12590B	1	29 *	SLINGER RING	5053 19120	1
4	STUD	C1011 15991	10	30 *	OIL SEAL	25217-601	1
5	HEX NUT	D10 15991	24	31	PIPE PLUG	P02 15079	1
6	AIR VENT FITTING	S2162	1	32	SEAL PLATE	4179F 10010	1
7	PIPE NIPPLE	T0206 15079	1	33 *	GASKET	4180G 18000	2
8	PIPE CPLG 1/8	AE02 15079	1	34	STUD	C1012 15991	2
9	BOTTLE OILER	S1933	1	35	PIPE PLUG	P12 15079	2
10	PIPE ELBOW	R02 11999	1	36	SHAFT NUT	4190B 11010	1
11	PIPE NIPPLE	T0212 15079	1	37	A HD SET SCREW	GA0601-1/2 17090	2
12	RD HD MACH SCREW	X0404 15991	2	38	INSERT	31111-003 23050	2
13	HEX HEAD CAP SCREW	B0605 15991	10	39 *	WEAR RING	4182A 14000	1
14	LOCK WASHER	J06 15991	10	40 *	WEAR RING	4181A 14000	1
15 *	OIL SEAL	25227-629	2	41	PIPE PLUG	P06 15079	2
16 *	BALL BEARING	23421-461	1	42	SUCTION HEAD	4180 10010	1
17	VENTED PIPE PLUG	38649-009 15079	1	43	STUD	C1009 15991	12
18 *	BALL BEARING	S1077	1	44	WDF KEY	AV1210 15990	1
19 *	GASKET	5413G 18000	1	45	PIPE PLUG	P24 10009	1
20	BEARING CAP	4185A 10010	1	NOT SHOWN			
21 *	KEY	N0616 15990	1		DRIVE SCREW	BM#04-03 17000	4
22	IMPELLER SHAFT	38516-202 1706H	1		ROTATION DECAL	2613M	1
23	BEARING SHIM SET	8546 15990	1		WARNING DECAL	2613FE	1
24	SIGHT GAUGE	S1471	2		STRAINER	4990	1
25	PIPE PLUG	P04 15079	1				
26	PEDESTAL	3233D 10010	1				

* INDICATES PARTS RECOMMENDED FOR STOCK

☞ INCLUDED WITH REPAIR 46474-306 1
 PUMP CASING ASSY

PUMP AND SEAL DISASSEMBLY AND REASSEMBLY

Review all SAFETY information in Section A.

Follow the instructions on all tags, label and decals attached to the pump.

This pump requires little service due to its rugged, minimum-maintenance design. However, if it becomes necessary to inspect or replace the wearing parts, follow these instructions which are keyed to Figure 1 and the accompanying parts list.

This manual will alert personnel to known procedures which require special attention, to those which could damage equipment, and to those which could be dangerous to personnel. However, this manual cannot possibly anticipate and provide detailed precautions for every situation that might occur during maintenance of the unit. Therefore, it is the responsibility of the owner/maintenance personnel to ensure that **only** safe, established maintenance procedures are used, and that any procedures not addressed in this manual are performed **only** after establishing that neither personal safety nor pump integrity are compromised by such practices.

Before attempting to service the pump, disconnect or lock out the power source to ensure that the pump will remain inoperative. Close all valves in the suction and discharge lines.

For power source disassembly and repair, consult the literature supplied with the power source, or contact your local power source representative.



Before attempting to open or service the pump:

1. **Familiarize yourself with this manual.**
2. **Disconnect or lock out the power source to ensure that the pump will remain inoperative.**
3. **Allow the pump to completely cool if overheated.**

4. **Check the temperature before opening any covers, plates, or plugs.**
5. **Close the suction and discharge valves.**
6. **Vent the pump slowly and cautiously.**
7. **Drain the pump.**



Use **Only Genuine Gorman—Rupp** replacement parts. Failure to do so may create a hazard and damage the pump or diminish optimal pump performance. Any such hazard, damage or diminished performance is not covered by the warranty.

NOTE

When appropriate recycling facilities are available, the user should recycle components and fluids when doing any routine maintenance / repairs and also at the end of the pump's useful life. All other components and fluids shall be disposed of according to all applicable codes and regulations.

Suction Head And Wear Ring Removal

Before attempting to service the pump, remove the casing drain plug (35) and drain the pump. Clean and re-install the drain plug.

Disconnect the suction and discharge piping. Remove the hardware securing the suction head (42) to the base. Support the suction head using a suitable hoist and sling. Disengage the hardware (43) and separate the suction head and wear ring (44) from the pump casing. Remove the suction head gasket (33) and clean the mating surfaces.

Inspect the wear ring for excessive wear or scoring. The wear ring is a press fit into the suction head. If replacement is required, use a small bit to drill three holes horizontally, 180° apart, through the wear ring between each of the spiral pins. Use a chisel or other suitable tool to complete the cuts through the wear ring. **Use caution** not to damage the suction head bore. Remove the wear ring sections from the suction head.

If no further disassembly is required, see **Suction Head and Wear Ring Installation**.

Pump Casing Removal



Death or serious personal injury and damage to the pump or components can occur if proper lifting procedures are not observed. Make certain that hoists, chains, slings or cables are in good working condition and of sufficient capacity and that they are positioned so that loads will be balanced and the pump or components will not be damaged when lifting. Suction and discharge hoses and piping **must** be removed from the pump before lifting. Lift the pump or component only as high as necessary and keep personnel away from suspended objects.

Support the pump casing using a suitable hoist and sling.

Remove the hardware (5 and 34) securing the pump casing to the pedestal.

Pull the pump casing straight away from the pedestal to prevent binding on the impeller. Remove the casing gasket (33) and clean the contacting surfaces.

Impeller Removal

Before removing the impeller, remove the bottle oiler (9) and piping (10 and 11). Remove the seal cavity drain plug (25) and drain the seal cavity oil. This will prevent oil from escaping when the impeller is removed.

To loosen the impeller nut, the impeller shaft must first be disconnected from the power source. With the power source disengaged, install the key (21) in shaft keyway. Install a lathe dog on the drive end of the shaft with the "V" notch positioned over the shaft key.

Use a long piece of heavy bar stock and the lathe dog as shown in Figure E–2 to block shaft rotation. Use **caution** not to damage the shaft or keyway.

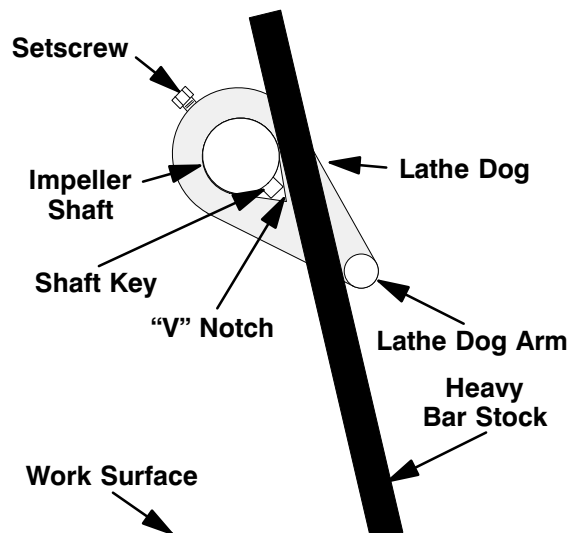

Figure E–2. Blocking Shaft Rotation

Loosen the two setscrews (37) and remove the impeller nut (36).

NOTE

If necessary, heat the impeller with a torch to aid in the removal.



The impeller is very heavy and could be damaged and/or could injure personnel if it is dropped. Use extreme caution when performing the following procedure to prevent dropping the impeller when it breaks loose from the shaft.

The impeller is secured to the shaft by the woodruff key (44) and a taper fit. To remove the impeller, install two 3/8-16 UNC capscrews (not supplied) in the tapped holes in the impeller. Use a gear puller to preload the impeller. Strike the gear puller shaft with a hammer to break the impeller loose. Remove the impeller and woodruff key.

NOTE

An alternate method of removing the impeller is to install two wedges 180° apart between the impeller and the seal plate. Tap the wedges alternately until the impeller breaks loose. If necessary, position a

piece of round bar stock against the end of the impeller shaft and strike the bar stock with a hammer to loosen the taper fit between the impeller and the shaft.

The wear ring (39) is a shrink fit on the impeller. Heat the wear ring to remove it from the impeller. **Use caution** not to damage the impeller. Pry or carefully grind the wear ring off the impeller.

Seal Removal

This pump is designed with two seals; a primary mechanical seal (3) located directly behind the impeller and a secondary oil seal (30) located at the back of the seal plate (32). If the liquid being pumped leaks past the oil seal, both seals should be replaced immediately.

Remove the air vent and piping (6, 7 and 8) from the seal plate (32).

Remove the seal spring. Apply oil to the shaft in the area of the mechanical seal bellows. Slide the rotating portion of the seal off the shaft.

Remove the machine screws (37) and slide the seal plate, remaining stationary mechanical seal components, and oil seal off the shaft as a unit. **Be careful** not to drop or damage the seal components when removing the seal plate.

Use a dowel or other suitable tool to press the stationary element, seat and O-rings out of the seal plate from the back side.

Use a screwdriver or other suitable tool to press or pry the oil seal (30) out of the seal plate. Be careful not to scratch or damage the seal plate bore.

If no further disassembly is required, refer to **Seal Installation**.

Shaft and Bearing Removal and Disassembly

When the pump is properly operated and maintained, the pedestal should not require disassembly. Disassemble the shaft and bearings **only** when there is evidence of wear or damage.



Shaft and bearing disassembly in the field is not recommended. These operations should be performed only in a properly equipped shop by qualified personnel.

Remove the pedestal drain plug (25) and drain the oil from the pedestal. Clean and reinstall the pipe plug.

Remove the hardware securing the pedestal (26) to the base. Remove the shaft key (21).

Remove the hardware (13 and 14) and slide the outboard bearing cap and oil seal (20 and 15) off the shaft as a unit. Remove the bearing cap gasket (19) and bearing adjusting shims (23). Tie and tag the shims or measure and record their thickness for ease of reassembly.

Press the oil seal out of the bearing cap.

Remove the hardware (13 and 14) and slide the inboard bearing cap and oil seal (15 and 28) off the shaft as a unit. Remove the bearing cap gasket (27).

Press the oil seal out of the bearing cap.

Place a block of wood against the impeller end of the shaft and tap the shaft and assembled bearings (16 and 18) from the pedestal bore. **Be careful** not to damage the shaft.

After removing the shaft and bearings, clean and inspect the bearings **in place** as follows.



To prevent damage during removal from the shaft, it is recommended that bearings be cleaned and inspected **in place**. It is **strongly** recommended that the bearings be replaced **any** time the shaft and bearings are removed.

Clean the pedestal, shaft and all component parts (except the bearings) with a soft cloth soaked in cleaning solvent. Inspect the parts for wear or damage and replace as necessary.



Most cleaning solvents are toxic and flammable. Use them only in a well ventilated area free from excessive heat, sparks, and flame. Read and follow all precautions printed on solvent containers.

Clean the bearings thoroughly in **fresh** cleaning solvent. Dry the bearings with filtered compressed air and coat with light oil.

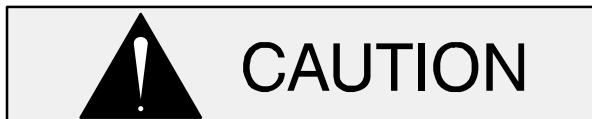

Bearings must be kept free of all dirt and foreign material. Failure to do so will greatly shorten bearing life. **Do not** spin dry bearings. This may scratch the balls or races and cause premature bearing failure.

Rotate the bearings by hand to check for roughness or binding. Inspect the bearing balls (or rollers) on open-type bearings. If rotation is rough or the balls or rollers are discolored, replace the bearings.

The bearing tolerances provide a tight press fit onto the shaft and a snug slip fit into the pedestal. Replace the bearings, shaft, or pedestal if the proper bearing fit is not achieved.

If bearing replacement is required, use a bearing puller to remove the bearings from the shaft.

Shaft and Bearing Reassembly and Installation

Clean and inspect the bearings as indicated in **Shaft and Bearing Removal and Disassembly**.



To prevent damage during removal from the shaft, it is recommended that bearings be cleaned and inspected **in place**. It is **strongly** recommended that the bearings be replaced **any** time the shaft and bearings are removed.

Inspect the shaft for distortion, nicks or scratches, or for thread damage on the impeller end. Dress small nicks and burrs with a fine file or emery cloth. Replace the shaft if defective.

NOTE

*If a hot oil bath is used to heat the bearings, both the oil and the container must be **absolutely** clean. If the oil has been previously used, it must be **thoroughly** filtered.*



Use caution when handling hot bearings to prevent burns.

Heat the bearings to a uniform temperature **no higher than 250°F (120°C)**, and slide the bearings onto the shaft, one at a time, until they are fully seated. This should be done quickly, in one continuous motion, to prevent the bearings from cooling and sticking on the shaft.

NOTE

Position the inboard bearing (16) on the shaft as indicated by the following illustrations.

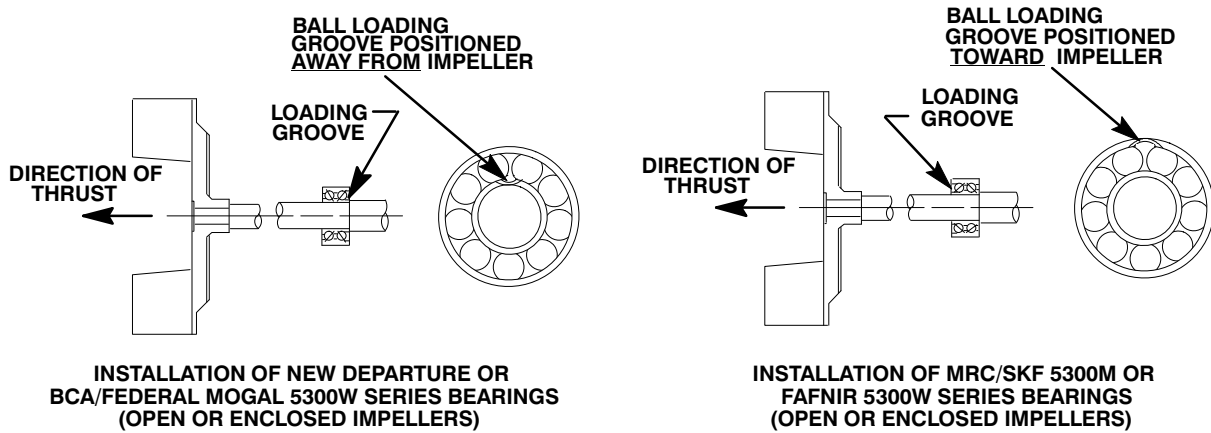
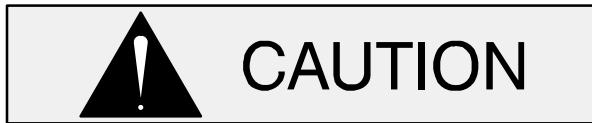

Figure E—3. Bearing Installation

After the bearings have been installed and allowed to cool, check to ensure that they have not moved away from the shaft shoulders in shrinking. If movement has occurred, use a suitably sized sleeve and a press to reposition the bearings against the shaft shoulders.

If heating the bearings is not practical, use a suitably sized sleeve and an arbor (or hydraulic) press to install the bearings on the shaft.



When installing the bearings onto the shaft, **never** press or hit against the outer race, balls, or ball cage. Press **only** on the inner race.

Press the oil seal (15) into the inboard bearing cap (28) with the lip positioned as shown in Figure 1. Center the seal in the bearing cap. Replace the bearing cap gasket (27) and secure the bearing cap to the pedestal with the hardware (13 and 14).

Slide the shaft and assembled bearings into the pedestal until the inboard bearing is fully seated against the bearing cap. **Be careful** not to roll or damage the oil seal lip.

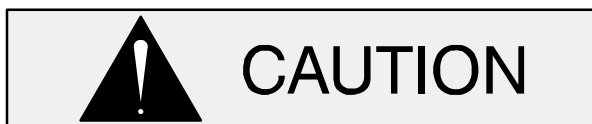

When installing the shaft and bearings into the pedestal bore, push against the outer race. **Never** hit the balls or ball cage.

Press the oil seal (15) into the outboard bearing cap (20) with the lip positioned as shown in Figure 1. Center the seal in the bearing cap. Replace the bearing cap gasket (19). Install the same thickness of bearing adjusting shims (23) as previously removed and secure the bearing cap to the pedestal with the hardware (13 and 14). **Be careful** not to roll or damage the oil seal lip on the shaft keyway.

NOTE

Shaft endplay should be between .002 and .010 inch (0,05 and 0,25 mm). Add or remove adjusting shims to establish the correct endplay.

Secure the pedestal to the base with the previously removed hardware. Install the shaft key (21). Be sure to reinstall any leveling shims used under the pedestal mounting feet.

Lubricate the bearings and pedestal as indicated in **LUBRICATION** at the end of this section.

Seal Reassembly and Installation

(Figures 1 and 2)

Clean the seal cavity and shaft with a cloth soaked in fresh cleaning solvent.



Most cleaning solvents are toxic and flammable. Use them only in a well ventilated area free from excessive heat, sparks, and flame. Read and follow all

precautions printed on solvent containers.

Inspect the impeller shaft for damage. Small scratches or nicks may be removed with a fine file or emery cloth. If excessive wear exists, the shaft will have to be replaced.

The seal is not normally reused because wear patterns on the finished faces cannot be realigned during reassembly. This could result in premature failure. If necessary to reuse an old seal in an emergency, **carefully** wash all metallic parts in **fresh** cleaning solvent and allow to dry thoroughly.

Handle the seal parts with extreme care to prevent damage. Be careful not to contaminate precision finished faces; even fingerprints on the faces can shorten seal life. If necessary, clean the faces with a

non-oil based solvent and a clean, lint-free tissue. Wipe **lightly** in a concentric pattern to avoid scratching the faces.

Inspect the seal components for wear, scoring, grooves, and other damage that might cause leakage. If any components are worn, replace the complete seal; **never mix old and new seal parts.**

If a replacement seal is being used, remove it from the container and inspect the precision finished faces to ensure that they are free of any foreign matter.

To ease installation of the seal, lubricate the O-rings and bellows with "P-80[®] Emulsion" or water, and apply a drop of light lubricating oil on the finished faces. Assemble the seal as follows (see Figure E-4).

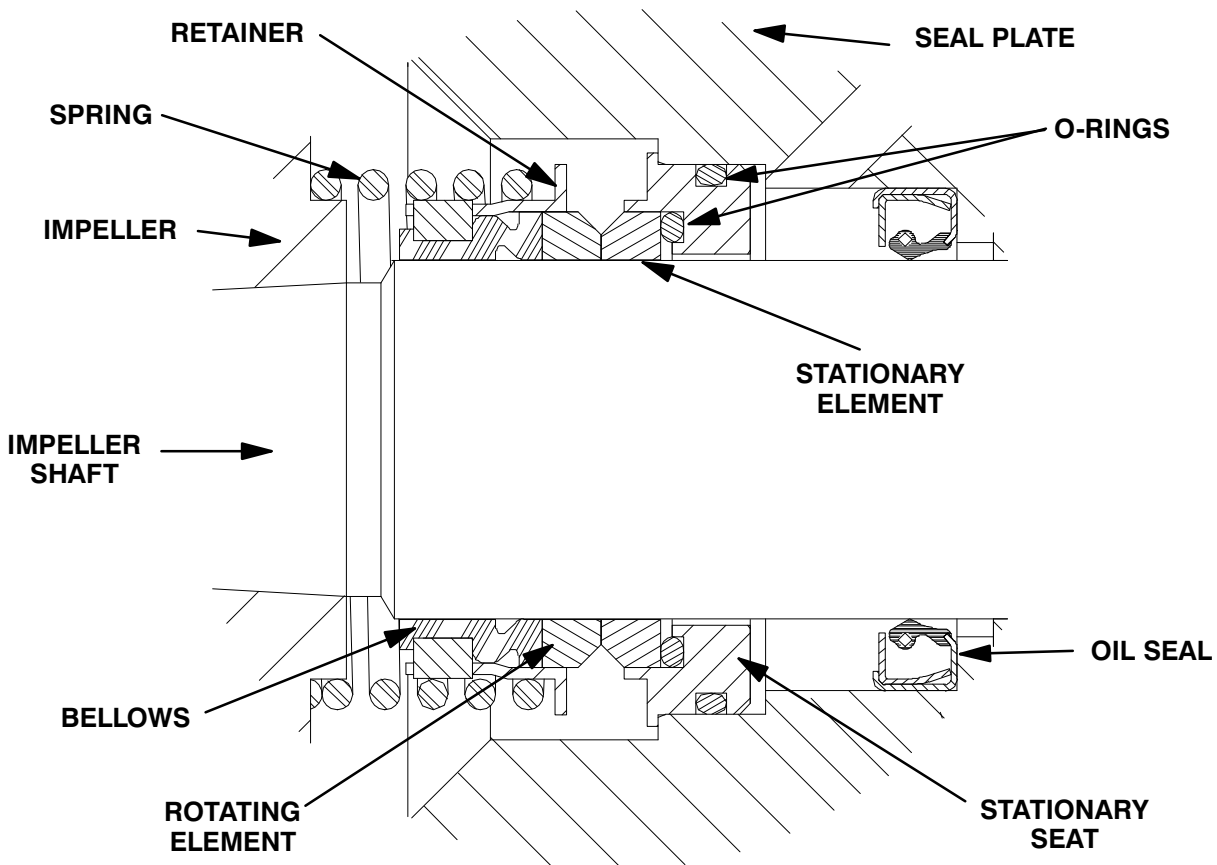
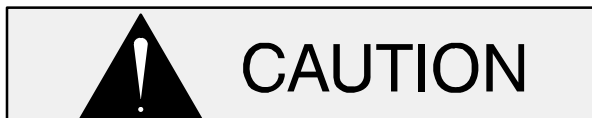

Figure E-4. 12590B Seal Assembly



This seal is not designed for operation at

temperatures above 160°F (71°C). Do not use at higher operating temperatures.

Lay the seal plate on a flat surface with the impeller side up. Press the oil seal (30) into the seal plate (32) with the lip positioned as shown in Figure 1.

Press the stationary subassembly (consisting of the stationary seat, O-rings and stationary element) into the seal plate until fully seated.

Slide the seal plate onto the shaft and secure it to the pedestal (26) with the round head machine screws (12). **Use caution** not to damage the stationary portion of the seal on the shaft shoulders.

Slide the rotating subassembly (consisting of the rotating element, retainer and bellows) onto the lubricated shaft until the seal elements contact. Install the seal spring.

Reinstall the air vent and piping (6, 7 and 8) and bottle oiler and piping (9, 10 and 11). Lubricate the seal assembly as indicated in **LUBRICATION**, after the impeller is installed.

Impeller Installation

Inspect the impeller, and replace it if cracked or badly worn. If the wear ring (39) was removed, chill the impeller by refrigeration and use an induction heater or oven to heat the wear ring. Slide the wear ring onto the impeller until fully seated against the shoulder and allow it to cool.

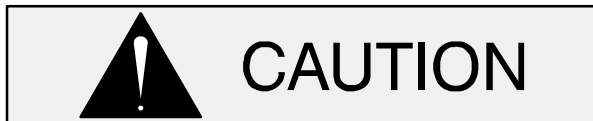

The wear ring **must** seat squarely on the impeller; otherwise binding and/or excessive wear will occur. Use caution when handling hot parts to prevent burns.

Install the woodruff key (44) and press the impeller onto the shaft until fully seated.

Remove the setscrews (37) from the impeller nut (36). Apply “Never-Seez” or equivalent compound to the shaft threads and screw the impeller nut onto the shaft. Immobilize the impeller as shown in Figure E—2, and torque the impeller nut to 300 ft. Lbs. (42 m. kg.).

Apply “Loctite No. 242” or equivalent compound to the setscrews (37). Install new inserts (38), and

torque the setscrews to 18 ft. lbs. (216 in. lbs. or 2,5 m. kg.).

Pump Casing Installation

Install the casing gasket (33) over the pump casing studs (4 and 34). Use a suitable hoist and sling to position the casing over the impeller and slide the studs through the seal plate and pedestal mounting holes.

Install the air vent and piping (6, 7 and 8). Secure the bracket and casing with the hardware (5 and 34).

Suction Head And Wear Ring Installation

If the wear ring (40) was removed, chill the wear ring by refrigeration and use an oven to heat the suction head. Press the wear ring into the suction head until fully seated and allow it to cool.



The wear ring **must** seat squarely in the suction head; otherwise binding and/or excessive wear will occur. Use caution when handling hot parts to prevent burns.

Install the suction head gasket (33) over the studs (43). Position the suction head over the studs and secure it with the nuts (5).

Rotate the impeller shaft by hand to check for scraping or binding and correct any before putting the pump back into service.

LUBRICATION

Seal Assembly

Fill the bottle oiler (9) with SAE No. 30 non-detergent oil. Check the oil level regularly and refill as required.

Bearings

The pedestal was fully lubricated when shipped from the factory. Check the oil level regularly through the sight gauges (24) and maintain it at the midpoint of the gauges. When lubrication is re-

quired, remove the vented plug (17) and add SAE No. 30 non-detergent oil through the opening. Clean and reinstall the vented plug. **Do not** over-lubricate. Over-lubrication can cause the bearings to over-heat, resulting in premature bearing failure.

NOTE

The white reflector in the sight gauge must be positioned horizontally to provide proper drainage.

Under normal conditions, drain the bearing housing once each year and refill with clean oil. Change the oil more frequently if the pump is operated continuously or installed in an environment with rapid temperature change.



Monitor the condition of the bearing lubricant regularly for evidence of rust or moisture condensation. This is especially important in areas where variable hot and cold temperatures are common.

For cold weather operation, consult the factory or a lubricant supplier for the recommended grade of oil.

Power Source

Consult the literature supplied with the power source, or contact your local power source representative.

**For Warranty Information, Please Visit
www.grpumps.com/warranty
or call:
U.S.: 419-755-1280
Canada: 519-631-2870
International: +1-419-755-1352**

GORMAN-RUPP PUMPS