

A B C D H

OM-01500-0M13

June 15, 1981

Rev. C

DSERIES

INSTALLATION, OPERATION, PARTS LIST, AND MAINTENANCE MANUAL

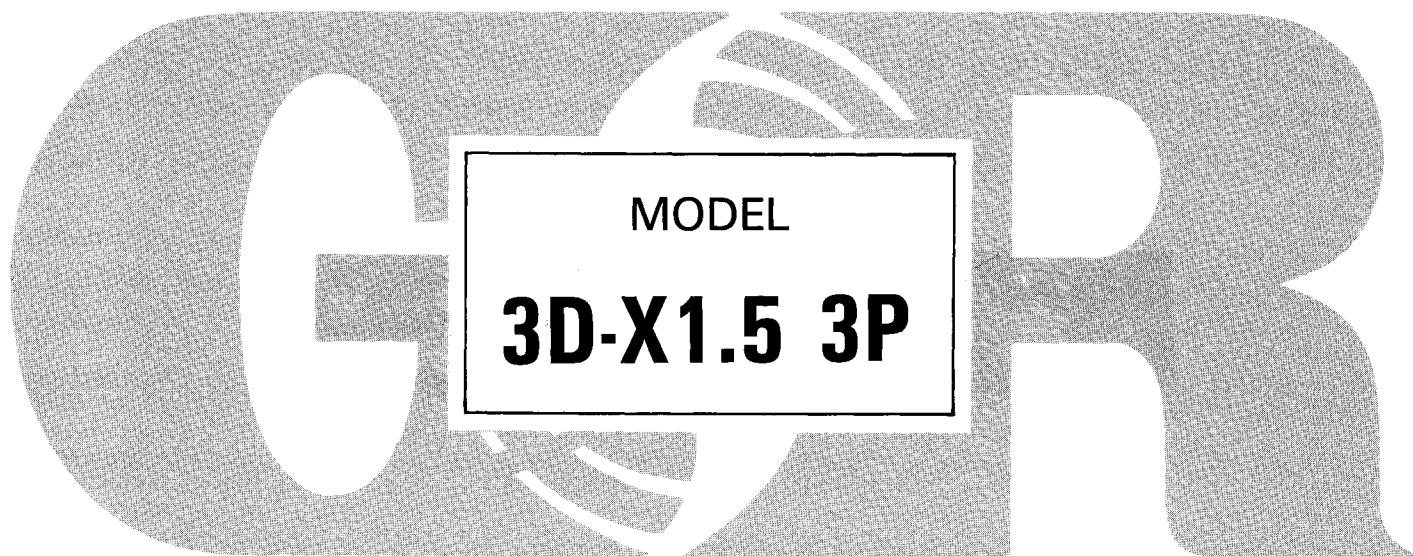

THE GORMAN-RUPP COMPANY • MANSFIELD, OHIO

GORMAN-RUPP OF CANADA LIMITED • ST. THOMAS, ONTARIO, CANADA

Printed in U.S.A.

Copyright by the Gorman-Rupp Company



This Installation, Operation, and Maintenance Manual is designed specifically to help you achieve the best performance and longest life from your Gorman-Rupp diaphragm pump.

This is a positive displacement type pump utilizing a single-action diaphragm to produce a straight-through flow of liquid. Since this pump handles liquids ranging from clear water to construction-site muck, it is ideally suited to industrial and contactors' applications. The pump is equipped with a Class I/Group D, Class II/Groups E, F, and G (or) F and G explosion-proof motor. Consult The Gorman-Rupp Company for specific applications.

If you have any questions regarding the pump which are not covered in this manual or in other literature furnished with the unit, please contact your Gorman-Rupp distributor, or write:

The Gorman-Rupp Company	or	Gorman-Rupp of Canada Limited
P.O. Box 1217		70 Burwell Road
Mansfield, Ohio 44901		St. Thomas, Ontario N5P 3R7

For information or technical assistance on the motor, contact the local dealer or representative of the motor manufacturer.

The following are used to alert maintenance personnel to procedures which require special attention, to those which could damage equipment, and to those which could be dangerous to personnel:

NOTE

Instructions to aid in installation, operation, or maintenance, or which clarify a procedure.

CAUTION

Instructions which must be followed to avoid causing damage to the product or other equipment incidental to the installation. These described the procedure required and the damage which could result from failure to follow the procedure.

WARNING

Instructions which must be followed to avoid causing injury or death to personnel. These describe the procedure required and the injury which could result from failure to follow the procedure.

TABLE OF CONTENTS

WARNING	Section A
INSTALLATION	Section B
OPERATION	Section C
TROUBLESHOOTING	Section D
MAINTENANCE AND REPAIR	Section E
WARRANTY	



WARNINGS

THESE WARNINGS APPLY TO DIAPHRAGM PUMPS WITH EXPLOSION-PROOF ELECTRIC MOTOR DRIVE.

```

////////////////////////////////////////////////////////////////////////////////////////////////////////////////////////////////
//
// Before attempting to service the pump:
//   1. Familiarize yourself with this manual.
//   2. Disconnect the power supply to the motor to ensure that the pump
//      will remain inoperative.
//   3. Allow the pump to cool if overheated.
//   4. Drain the pump.
//
////////////////////////////////////////////////////////////////////////////////////////////////////////////////////////////////

```

```

////////////////////////////////////////////////////////////////////////////////////////////////////////////////////////////////
//
// This pump is designed to pump only non-flammable liquids. Do not attempt
// to pump volatile or corrosive liquids, or liquids which may attack pump fit-
// tings or components. Do not operate the pump in an explosive at-
// mosphere.
//
////////////////////////////////////////////////////////////////////////////////////////////////////////////////////////////////

```

```

////////////////////////////////////////////////////////////////////////////////////////////////////////////////////////////////
//
// Overheated pumps can cause severe burns and injury. If overheating of the
// pump occurs:
//   1. Stop the pump immediately.
//   2. Allow the pump to cool.
//   3. Refer to instructions in the manual before restarting the pump.
//
////////////////////////////////////////////////////////////////////////////////////////////////////////////////////////////////

```

```

////////////////////////////////////////////////////////////////////////////////////////////////////////////////////////////////
//
// Never install a positive shut-off valve in the discharge line; discharge
// restrictions will cause excessive friction loss resulting in overloading and
// destruction of pump and drive components. It is strongly recommended
// that unless absolutely necessary, no positive shut-off valve be installed in
// the suction line; excessive restriction will cause incomplete filling of the
// diaphragm chamber and result in short diaphragm life.
//
////////////////////////////////////////////////////////////////////////////////////////////////////////////////////////////////

```



//
//
// Do not operate the pump without the eccentric guard assembly and coupl- //
// ing guard in place. Exposed rotating parts can catch clothing, fingers, or //
// tools, causing severe injury to personnel. //
// //
//

//
//
// Install, connect, and operate the motor in accordance with the National //
// Electric Code and all local codes. If there is a conflict between the instruc- //
// tions in the manual accompanying the motor and the National Electric Code //
// or the applicable local code, the National or local code shall take //
// precedence. All electrical equipment supplied with this pump conformed to //
// applicable federal regulations and national codes in effect on the date of //
// manufacture. //
// //
//

//
//
// The electrical power applied to the motor of this pump is high enough to //
// cause injury or death. Ground the unit before connecting it to the electrical //
// power supply; never use gas piping as an electrical ground. Be sure to conn- //
// ect the motor to the correct phase and voltage. Do not run the pump if the //
// voltage is not within limits. If a circuit breaker or fuse is tripped, examine //
// and correct the problem before restarting the pump. //
// //
//

//
//
// Do not run this pump backward. Check rotation before fully operating the //
// pump. //
// //
//

//
//
// The input drive of the pump gear box is designed to be driven at 1825 RPM //
// **maximum**. A higher input RPM can cause pump components to break //
// down. //
// //
//

INSTALLATION

Pump installations are seldom identical. This section summarizes recommended installation practice relative to inspection, pump positioning, and suction and discharge piping. For further assistance, contact your Gorman-Rupp distributor, or the Gorman-Rupp Company.

Approximate physical dimensions of this pump are shown in figure 1.

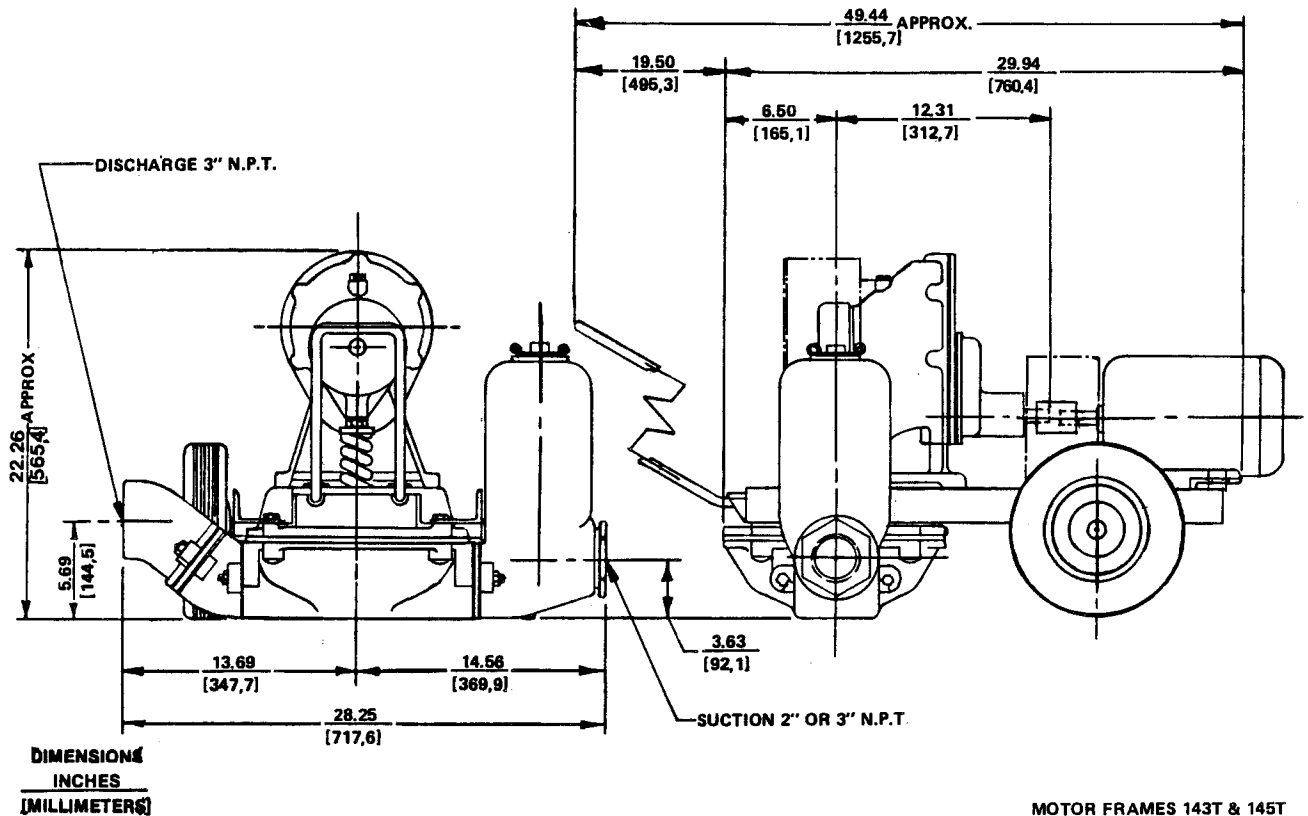

Figure 1. Pump Model 3D-X1.5 3P

Preinstallation Inspection

The pump assembly was inspected and tested before it was shipped from the factory. Before installation, check the pump for damage which may have occurred during shipment. Check as follows:

- Inspect the pump end, gear box assembly, and motor for cracks, dents, damaged threads, and other obvious damage.
- Check for and tighten loose bolts, nuts, capscrews, and other attaching hardware.
- Carefully read all tags, decals, and markings on the pump assembly, and follow the instructions indicated.
- Check all lubricant levels and lubricate as necessary (see LUBRICATION in Section E).



Positioning the Pump

Locate the pump as close as possible to the liquid to be pumped. Level mounting is essential for proper operation. Block the wheels to prevent creeping.

Lifting

////////////////////
//
// **WARNING** //
// Use lifting and moving equipment in good repair and //
// with adequate capacity to prevent injuries to person- //
// nel or damage to equipment. //
//
////////////////////

Make sure that hoists and other lifting equipment are of sufficient capacity to safely handle the pump assembly. If chains or cables are used, make certain that they are positioned so that they will not damage the pump, and so that the load will be balanced.

CAUTION

The pump assembly can be seriously damaged if the cables or chains used to lift and move the unit are improperly wrapped around it.

SUCTION AND DISCHARGE PIPING

Materials

Either pipe or hose may be used in suction or discharge lines, but hose used in suction lines must be the rigid-wall type to prevent collapse under suction.

Suction lines should be the same size as the pump inlet.

CAUTION

The discharge line should be the same size as, or larger than, the suction line. Never install or operate this pump with a discharge line smaller than the suction line; a restricted discharge line will cause excessive friction loss resulting in overloading and destruction of pump and drive components.



Fittings

Make minimum use of elbows and fittings, which substantially increase friction loss. If elbows are necessary, use the long-radius type to minimize friction loss.

If reducers are used in suction lines, they should be the eccentric type, and should be installed with the flat part of the reducers uppermost to avoid creating air pockers. Any reducers installed in the discharge line **must** be the same size as, or larger than, reducers installed in the suction line.

Using pipe couplings in suction lines is not recommended.

Gauges

If discharge pressure and vacuum suction gauges are desired, drill and tap the discharge and suction lines close to the pump before installing the lines.

Sealing

All threaded connections in the suction line should be sealed with pipe dope to ensure an airtight seal. Even a slight leak will affect priming, head and capacity, especially when operating with a high suction lift. After installation, inspect the suction line carefully for potential leaks.

Strainer

Install the strainer furnished with this pump at the end of the suction intake.

ALIGNMENT

This pump is driven by a motor connected to a gear box by a flexible coupling.

The pump end, gear box, and motor were aligned and secured at the factory, but fastening hardware may have become loosened during shipment. It is imperative to check alignment after the pump has been installed and before operation.

See Section C and check rotation before fully operating the pump.

```
////////////////////////////////////  
//                               //  
//                               //  
//                               //  
//                               //  
//                               //  
//                               //  
//                               //  
//                               //  
//                               //  
//                               //  
////////////////////////////////////
```

WARNING

Before checking alignment, disconnect the power source to ensure that the motor will remain inoperative.

Check and tighten the hardware securing the base, pump end, gear box, and motor, and check alignment. Adjustments may be made by loosening the securing hardware and shifting components, or by shimming as required.



OPERATION

////////////////////////////////////
//
// **WARNING** //
// //
// This pump is designed to pump only non-flammable //
// liquids. Do not attempt to pump volatile or explosive //
// liquids, or liquids which may attack pump fittings. Do //
// not operate the motor in an explosive atmosphere. //
// //
////////////////////////////////////

The particular service in which this pump is used will affect pump performance, especially discharge velocities. Consult the Gorman-Rupp factory for actual performance levels of this pump.

Refer to **LUBRICATION** in Section E, and check that the gear box is properly lubricated.

CAUTION

The pump end is designed to operate at 60 cycles per minute through a gear box with a 30.36:1 ratio and input drive of 1825 RPM **maximum**. Operation at higher RPM can cause pump components to break down.

Consult the manual(s) furnished with the pump motor before starting the pump.

////////////////////////////////////
//
// **WARNING** //
// //
// Never run this pump backwards. Be certain that rota- //
// tion is correct before fully engaging the pump. //
// //
////////////////////////////////////

Check rotation by starting the pump for a moment to see if the rotation is correct. Rotation can usually be determined by observing the motor cooling fan.

If rotation is incorrect, have qualified personnel change any of the two input power leads to the motor.



```

////////////////////////////////////
//                                     //
//                                     //
//                                     //
//                                     //
//                                     //
//                                     //
//                                     //
//                                     //
//                                     //
//                                     //
//                                     //
//                                     //
////////////////////////////////////

```

WARNING

```

//                                     //
// Make certain that any positive shut-off valve installed //
// in the suction line is open before operating the pump; //
// excessive restriction will cause incomplete filling of //
// the diaphragm chamber and result in short diaphragm //
// life. No positive shut-off valve should be installed in //
// the discharge line. //
//                                     //
//                                     //
////////////////////////////////////

```

The pump may not prime immediately because the suction line must first fill with liquid. If the pump fails to prime within five minutes, stop the pump and check the suction line for leaks.

Check the pump for unusual noises or excessive vibration while it is operating.

No leakage should be visible at pump mating surfaces, or at pump connections or fittings. Keep all line connections and fittings tight to maintain maximum pump efficiency.

```

////////////////////////////////////
//                                     //
//                                     //
//                                     //
//                                     //
//                                     //
//                                     //
//                                     //
//                                     //
//                                     //
//                                     //
//                                     //
//                                     //
////////////////////////////////////

```

WARNING

```

//                                     //
// Overheated pumps can cause severe burns and injury. //
// If overheating of the pump casing occurs: //
// 1. Stop the pump immediately. //
// 2. Allow the pump to cool. //
// 3. Refer to instructions in this manual before //
// restarting the pump. //
//                                     //
//                                     //
////////////////////////////////////

```

Check the strainer regularly during operation or if the flow rate begins to drop, and clean it as necessary. Be especially alert for unusual noises when pumping liquids containing solids.

After stopping the pump, disconnect the power supply to the motor to ensure that the pump will remain inoperative.

In below-freezing conditions, drain the water from the pump and the lines when the pump is not in operation. Also, clean out any solids by flushing with a hose.

If the pump will be idle for more than a few hours, or if it has been pumping liquid containing a large amount of solids, flush it with clean water.



TROUBLESHOOTING

```

////////////////////////////////////
//                               //
//                               //
//                               //
//                               //
//                               //
//                               //
//                               //
//                               //
//                               //
//                               //
//                               //
//                               //
////////////////////////////////////

```

WARNING

Before attempting to open or service the pump:

1. Familiarize yourself with this manual.
2. Disconnect the power supply to the motor to ensure that the pump will remain inoperative.
3. Allow the pump to cool if overheated.
4. Drain the pump.

Trouble	Possible Cause	Probable Remedy
PUMP FAILS TO PRIME	Air leak in suction line. Lining of suction hose collapsed. Integral suction or discharge check valve clogged, binding, or not seating properly. Cracked or broken diaphragm. Diaphragm not securely in place. Strainer clogged.	Correct leak. Replace suction hose. Clean valves. Check that flange nuts are tight. Replace diaphragm. Secure diaphragm. Clean strainer.
PUMP STOPS OR FAILS TO DELIVER RATED FLOW OR PRESSURE	Air leak in suction line. Suction intake not properly submerged. Strainer clogged. Lining of suction hose collapsed. Cracked or broken diaphragm. Diaphragm not securely in place. Suction lift or discharge head too high.	Correct leak. Check installation. Clean strainer. Replace suction hose. Replace diaphragm. Secure diaphragm. Check installation, and correct as required.

continued, page 2



Trouble	Possible Cause	Probable Remedy
continued from page 1	Integral suction or discharge check valve clogged, binding, or not seating properly.	Clean valves. Check that flange nuts are tight.
PUMP REQUIRES TOO MUCH POWER	Liquid solution too thick. Pump speed too high. Integral discharge check valve clogged or binding. Discharge head too high. Bearings in motor or gear box worn or binding.	Dilute if possible. Reduce motor speed. Clean valve. Shorten total discharge length or install larger diameter discharge line. Check bearings.
PUMP CLOGS FREQUENTLY	Integral suction or discharge check valve clogged, binding, or not seating properly.	Clean valves. Check that flange nuts are tight.
EXCESSIVE NOISE	Pump, gear box, or motor not securely mounted. Gear box not properly lubricated.	Check and tighten mounting bolts. See LUBRICATION , Section E.



MAINTENANCE AND REPAIR

MAINTENANCE AND REPAIR OF THE WEARING PARTS OF THE PUMP WILL MAINTAIN PEAK OPERATING PERFORMANCE.

PERFORMANCE TEST DATA FOR PUMP MODEL 3D-X1.5 3P

IN GALLONS PER MINUTE, 60 STROKES PER MINUTE

STATIC LIFT IN FEET	STATIC DISCHARGE HEAD IN FEET			
	5	10	15	20
5	78	67	66	68
10	73	64	66	62
15	68	60	64	59
20	64	59	65	59
25	56	56	60	56

IN LITERS PER MINUTE, 60 STROKES PER MINUTE

STATIC LIFT IN METERS	STATIC DISCHARGE HEAD IN METERS			
	1,5	3,0	4,6	6,1
1,5	295,2	253,6	249,8	257,4
3,0	276,3	242,2	249,8	234,7
4,6	257,4	227,1	242,2	223,3
6,1	242,2	223,3	246,0	223,3
7,6	212,0	212,0	227,1	212,0

*STANDARD PERFORMANCE FOR PUMP MODEL 3D-X1.5 3P

*Based on 70°F clear water at sea level with minimum suction lift, using 2-inch (5.08 cm.) suction hose and 3-inch (7.62 cm.) non-collapsible discharge hose.

Since pump installations are seldom identical, your performance may be different due to such factors as viscosity, specific gravity, elevation, and temperature.

If your pump serial number is followed by an "N" or if you have a question on performance, contact The Gorman-Rupp Company.

SECTIONAL DRAWING

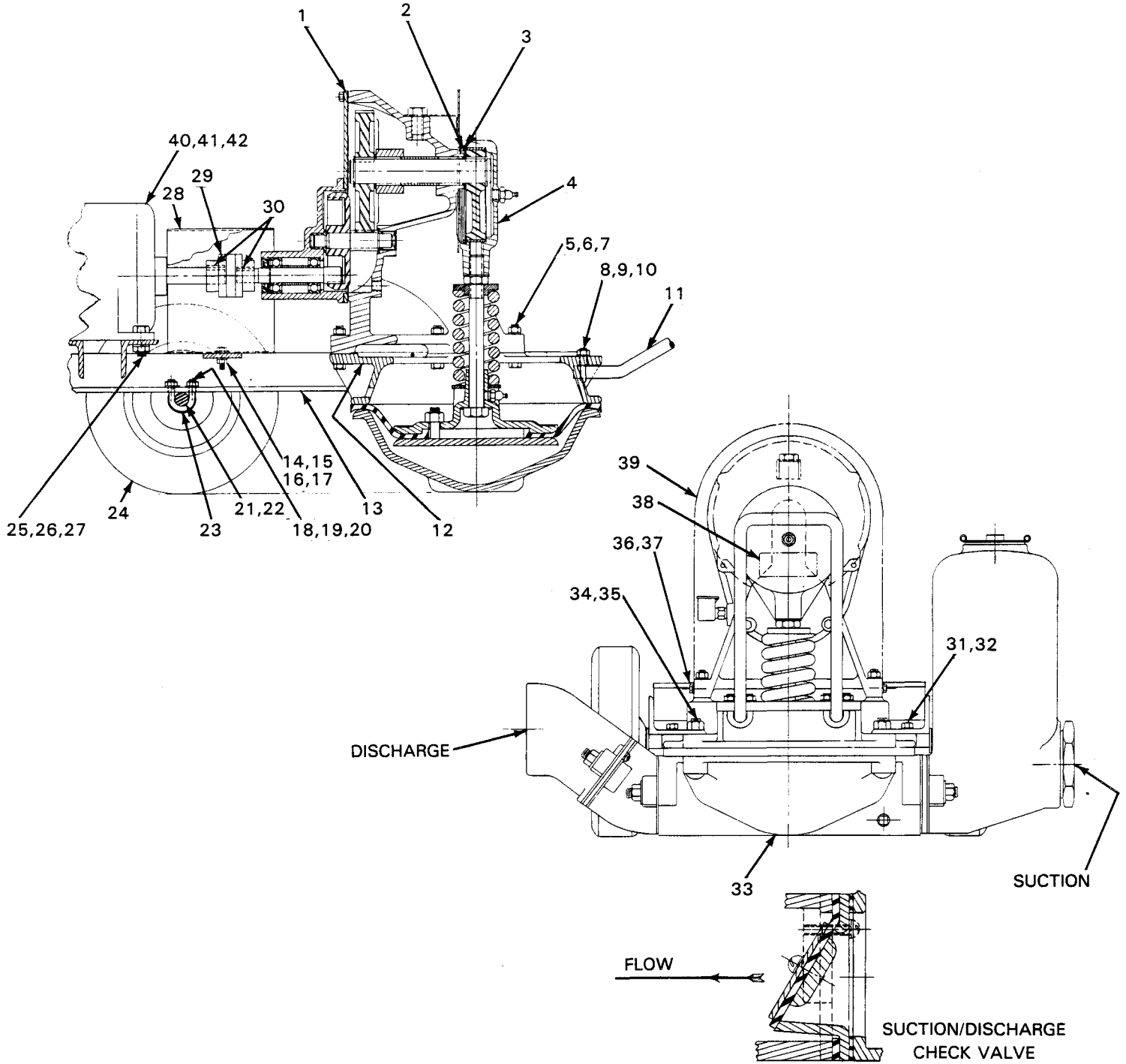

Figure 1. Pump Model 3D-X1.5 3P



PARTS LIST
PUMP MODEL 3D-X1.5 3P
(From S/N 507431 up)

ITEM NO.	PART NAME	PART NUMBER	MATL CODE	QTY	ITEM NO.	PART NAME	PART NUMBER	MATL CODE	QTY
1	GEARBOX ASSY (See fig. 4)	8981		1	27	LOCK WASHER	J-05	15991	4
2	SNAP RING	5385	00000	1	28	COUPLING GUARD	34613-005		1
3	CAM WASHER	6531	18040	REF	29	★ FLEXIBLE COUPLING	S-0826		1
4	PLNGR ROD ASSY (See fig. 3)	5685		1	30	★ COUPLING KEY	N-0304	15990	2
5	HEX HEAD CAPSCREW	B-0608	15991	5	31	HEX HEAD CAPSCREW	B-0604	15991	2
6	LOCK WASHER	J-06	15991	5	32	LOCK WASHER	J-06	15991	2
7	HEX NUT	D-06	15991	5	33	DIAPH POT ASSY (See fig. 2)	46475-701		1
8	U-BOLT	5495	15990	2	34	HEX NUT	D-08	15991	4
9	LOCK WASHER	J-06	15991	4	35	RIB MACHINE BOLT	BJ-0811	15990	REF
10	HEX NUT	D-06	15991	4	36	HEX HEAD CAPSCREW	B-0402	15991	4
11	DRAW BAR	5438	15990	1	37	LOCK WASHER	J-04	15991	4
12	DIAPHRAGM RING	13582	13010	1	38	LUBE DECAL	38816-085		1
13	BASE	13583	24000	1	39	ECCENTRIC GUARD ASSY	42381-030		1
14	HEX HEAD CAPSCREW	B-0404	15991	2	40	MOTOR, 1.5 HP	28274-440		1
15	FLAT WASHER	K-04	15991	2	41	HEAVY PIPE NIPPLE	THA-1206	15070	1
16	LOCK WASHER	J-04	15991	2	42	CONDUIT BOX	27144-103		1
17	HEX NUT	D-04	15991	2	NOT SHOWN:				
18	U-BOLT	5495	15990	2		NAME PLATE	2613-BP	13990	1
19	LOCK WASHER	J-06	15991	4		STRAINER	9026	24000	1
20	HEX NUT	D-06	15991	4		HEX NUT	D-06	15991	2
21	★ AXLE	4607-AD	15990	1	OPTIONAL:				
22	★ COTTER PIN	M-0306	15990	4		STATIONARY BASE, 143T			
23	SPACER WASHER	5382	15990	2		& 145T MOTOR FRAME	8105-B	24000	1
24	PNEUMATIC TIRE	S-0752		2		STATIONARY BASE, 182			
25	HEX HEAD CAPSCREW	B-0506	15991	4		& 184 MOTOR FRAME	8105	24000	1
26	HEX NUT	D-05	15991	4					

★ INDICATES PARTS RECOMMENDED FOR STOCK

Above Serial Numbers Do Not Apply To Pumps Made In Canada.

CANADIAN SERIAL NO.....AND UP

SECTIONAL DRAWING

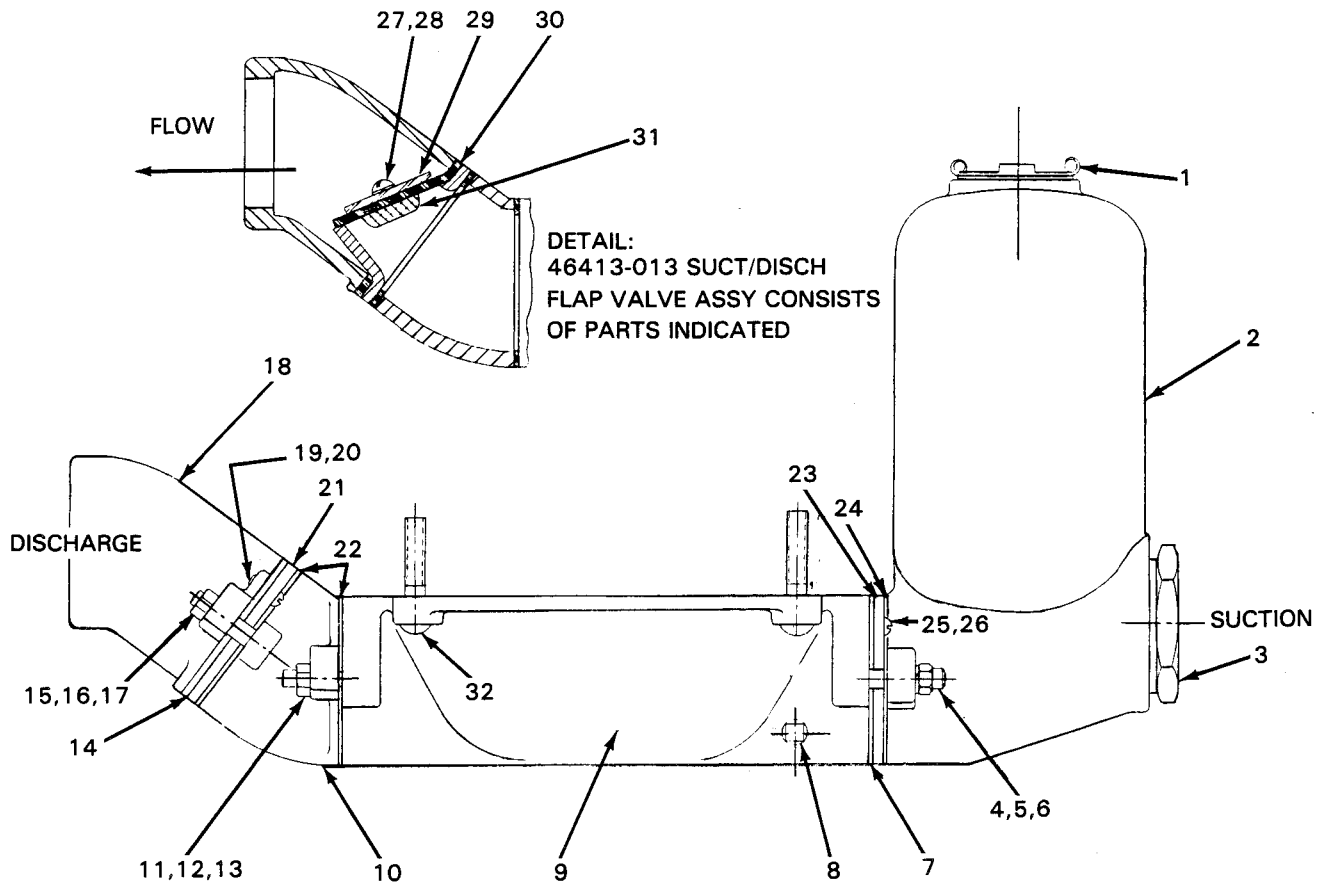

Figure 2. 46475-701 Diaphragm Pot Assembly



PARTS LIST

46475-701 DIAPHRAGM POT ASSEMBLY

ITEM NO.	PART NAME	PART NUMBER	MATERIAL CODE	QTY
1	SUCTION ACCUMULATOR PLUG & GSKT	S-0591		1
2	SUCTION ACCUMULATOR	5376	13010	1
3	REDUCING PIPE BUSHING	AP-4832	11990	1
4	STUD	C-0810	15991	2
5	HEX NUT	D-08	15991	2
6	FLAT WASHER	K-07	15991	2
7	SUCTION FLAP VALVE ASSEMBLY	46413-013		1
8	DIAPHRAGM POT DRAIN PLUG	P-06	11990	1
9	DIAPHRAGM POT	5375	13010	1
10	INBOARD DISCHARGE FLANGE	5377	13040	1
11	STUD	C-0809	15991	2
12	HEX NUT	D-08	15991	2
13	FLAT WASHER	K-07	15991	2
14	DISCHARGE FLAP VALVE ASSEMBLY	46413-013		1
15	STUD	C-0810	15991	2
16	HEX NUT	D-08	15991	2
17	WASHER	11273	15990	2
18	OUTBOARD DISCHARGE FLANGE	5658	13040	1
19	ROUND HEAD MACHINE SCREW	X-0404	15991	2
20	LOCK WASHER	J-04	15991	2
21	★DISCHARGE FLAP VALVE SEAT	5374	10010	1
22	★GASKET	5374-G	19100	2
23	★SUCTION FLAP VALVE SEAT	5374	10010	1
24	★GASKET	5374-G	19100	1
25	ROUND HEAD MACHINE SCREW	X-0404	15991	2
26	LOCK WASHER	J-04	15991	2
27	ROUND HEAD MACHINE SCREW	X-0403	15991	4
28	LOCK WASHER	J-04	15991	4
29	★FLAP VALVE WEIGHT	5428	15990	2
30	★FLAP VALVE	5427	19100	2
31	★FLAP VALVE WEIGHT	5426	13010	2
32	RIB MACHINE BOLT	BJ-0811	15990	4

★ Indicates Parts Recommended for Stock

SECTIONAL DRAWING

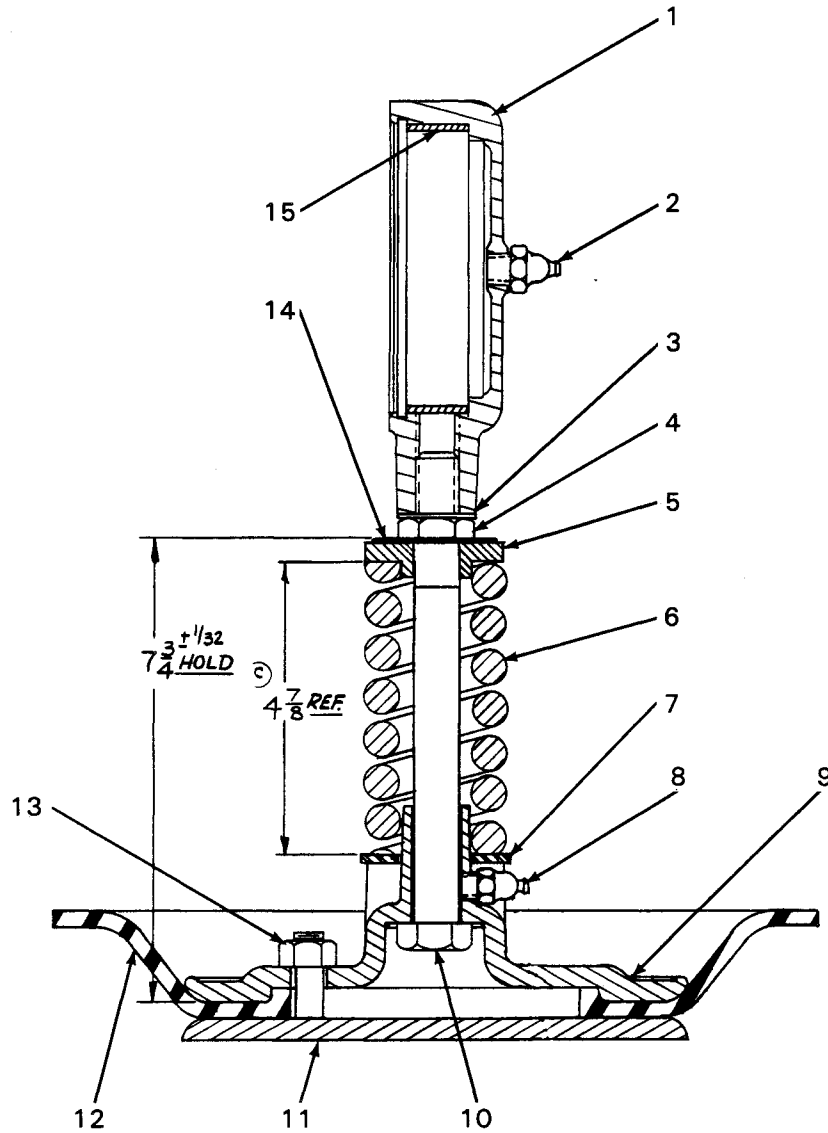

Figure 3. 5685 Plunger Rod Assembly



PARTS LIST

5685 PLUNGER ROD ASSEMBLY

ITEM NO.	PART NAME	PART NUMBER	MATERIAL CODE	QTY
1	ECCENTRIC CAP	5373	13010	1
2	LUBE FITTING	S-0191		1
3	T-LOCKWASHER	AK-12	15991	1
4	JAM NUT	AT-12	15990	1
5	SPRING WASHER	5384	15990	1
6	★ SPRING	5398	16080	1
7	FLAT WASHER	K-20	15991	1
8	LUBE FITTING	S-0191		1
9	UPPER DIAPHRAGM PLATE	5381	10010	1
10	PLUNGER ROD	21612-577	-----	1
11	LOWER DIAPHRAGM PLATE ASSEMBLY	5394		1
12	★ DIAPHRAGM	S-0701		1
13	HEX NUT	D-08	15991	3
14	★ ADJUSTING SHIM	11840-B	15990	4
15	★ ECCENTRIC BEARING	5610	14000	1

★ Indicates Parts Recommended for Stock

SECTIONAL DRAWING

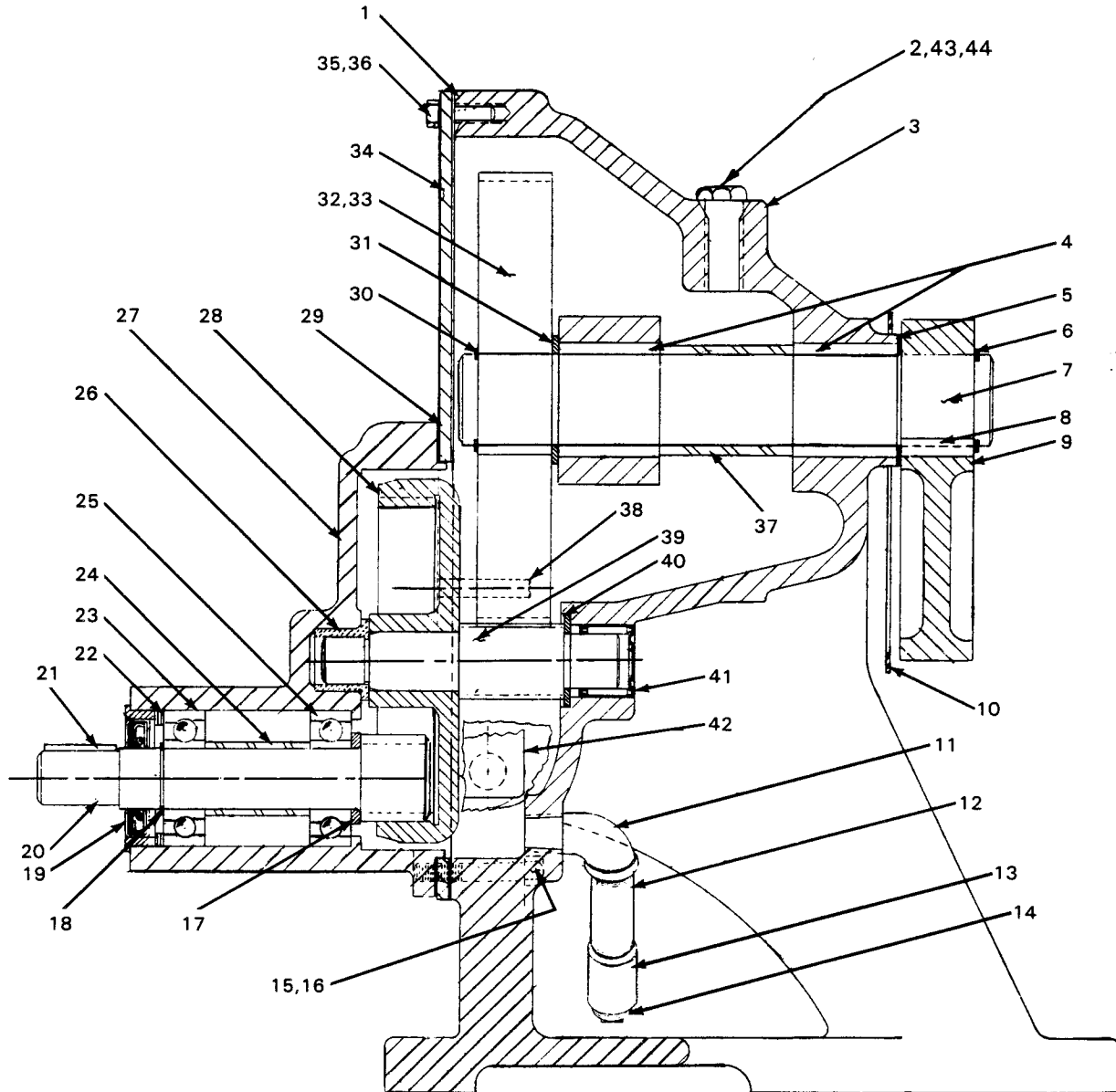

Figure 4. 8981 Gearbox Assembly



PARTS LIST

8981 GEARBOX ASSEMBLY

ITEM NO.	PART NAME	PART NUMBER	MATL CODE	QTY	ITEM NO.	PART NAME	PART NUMBER	MATL CODE	QTY
1	★COVER PLATE GASKET	5367-G	20050	1	23	★DRIVE SHAFT BEARING	S-1044		1
2	HEX HEAD CAPSCREW	B-1004	15991	1	24	SLEEVE	5922	15070	1
3	GEARBOX HOUSING	5367	13010	1	25	★DRIVE SHAFT BEARING	S-1044		1
4	★ECC CAM SHAFT BRNG	S-0702		2	26	★PINION SHAFT BEARING	S-0824		1
5	★ADJUSTING SHIM SET	13103-A	15990	1	27	BEARING HOUSING	5918	13010	1
6	CAM SNAP RING	S-0700		1	28	★PINION GEAR	S-0823		1
7	★ECCENTRIC CAM SHAFT	5397	15020	1	29	★BEARING HOUSING GSKT	S-0825		1
8	★CAM KEY	31811-040	15990	1	30	GEAR SNAP RING	S-0700		1
9	ECCENTRIC CAM	5378-A	10800	1	31	SPACER WASHER	5395	15990	1
10	CAM WASHER	6531	18040	1	32	★GEAR	5334	16060	1
11	STREET ELBOW	RS-04	11990	1	33	★GEAR KEY	31811-040	15990	1
12	PIPE NIPPLE	T-0408	15070	1	34	GEARBX HSG CVR PLATE	5396	15990	1
13	PIPE COUPLING	AE-04	11990	1	35	HEX HEAD CAPSCREW	B-0403	15991	7
14	GEARBOX DRAIN PLUG	P-04	11990	1	36	LOCK WASHER	J-04	15991	7
15	HEX HEAD CAPSCREW	B-0407	15991	2	37	SPACER SLEEVE	S-0952		1
16	LOCK WASHER	J-04	15991	2	38	GEARBX HSG DOWEL PIN	AA-0405	15990	2
17	DRIVE SHAFT WASHER	5921	15990	1	39	★PINION SHAFT	5333	16020	1
18	BEARING SNAP RING	S-0269		1	40	SPACER WASHER	5382	15990	1
19	★OIL SEAL ASSEMBLY	14408		1	41	★PINION SHAFT BEARING	S-0703		1
20	★DRIVE SHAFT	5917	16070	1	42	GEARBOX OIL CUP	S-0617		1
21	★DRIVE SHAFT KEY	N-0304	15090	1	43	LOCK WASHER	J-10	15991	1
22	DRIVE SHAFT WASHER	2-M	15990	3	44	FLAT WASHER	K-10	15991	1

★INDICATES PARTS RECOMMENDED FOR STOCK

Above Serial Numbers Do Not Apply To Pumps Made In Canada.

CANADIAN SERIAL NO.....AND UP



PUMP ASSEMBLY DISASSEMBLY AND REASSEMBLY

This pump requires little service due to its rugged, minimum-maintenance design. If it becomes necessary to inspect or replace components, however, follow these instructions, which are keyed to the sectional views (see figures 1 through 4) and the accompanying parts lists.

```
////////////////////////////////////  
//                               //  
//                               //  
//                               //  
//                               //  
//                               //  
//                               //  
//                               //  
//                               //  
//                               //  
//                               //  
//                               //  
////////////////////////////////////
```

WARNING

Before performing any maintenance or repair, or disassembling this pump, disconnect the power supply to the motor to ensure that the pump will remain imperative.

MOTOR SEPARATION (See figure 1)

NOTE

It is not necessary to remove the motor to disassemble the pump assembly.

Remove the hex head capscrews (14), flat washers (15), lock washers (16), and hex nuts (17) securing the coupling guard (28) to the base assembly (13), and remove the coupling guard.

Remove the hex head capscrews (25), hex nuts (26), and lock washers (27) securing the motor (1) to the base assembly.

Disengage the motor drive shaft from the coupling (29), retaining the drive shaft key (30), and separate the motor from the pump assembly.

PUMP ASSEMBLY DISASSEMBLY (See figure 1)

Close all connecting valves, and drain the pump by removing the drain plug (8, figure 2). Clean and reinstall the drain plug.

Remove the eccentric guard assembly (39) by removing the hex head capscrews (36) and lock washers (37) securing the eccentric guard to the gear box assembly (1).

To remove the diaphragm pot assembly (33), remove the hex nuts (34) securing the diaphragm pot to the diaphragm ring (12).

To remove the plunger rod assembly (4), remove the snap ring (2) securing the assembly to the gear box cam shaft.

To remove the gear box assembly, remove the hex head capscrews (5), lock washers (6), and hex nuts (7) securing the gear box to the diaphragm ring, disengage the gear box drive shaft from the coupling (29), retaining the drive shaft key (30), and remove the gear box.

Diaphragm Pot Disassembly (See figure 2)

To remove the suction accumulator (2), remove the hex nuts (5) and flat washers (6) securing the accumulator to the diaphragm pot (9).

To remove the suction flap valve assembly (7), remove the round head machine screws (25) and lock washers (26) securing the valve seat (23) and flap valve assembly to the diaphragm pot.

To remove the inboard discharge flange (10), remove the hex nuts (12) and flat washers (13) securing the flange to the diaphragm pot.

To remove the outboard discharge flange (18), remove the hex nuts (16) and washers (17) securing the flange to the inboard discharge flange.

To remove the discharge flap valve assembly (14), remove the round head machine screws (19) and lock washers (20) securing the valve seat (21) and flap valve assembly to the outboard discharge flange.

The suction and discharge flap valve assemblies are identical parts, and operate in the same direction. For removal and/or replacement of flap valve components, remove the round head machine screws (27) and lock washers (28).

Plunger Rod Disassembly (See figure 3)

To remove the diaphragm (12), remove the hex nuts (13) securing the lower diaphragm plate assembly (11) to the upper diaphragm plate (9).

To separate the upper diaphragm plate, flat washer (7), spring (6), spring washer (5), adjusting shims (14), jam nut (4), and T-lockwasher (3), unscrew the plunger rod (10) from the eccentric cap (1).

The eccentric bearing (15) is a press fit in the eccentric cap.

Gear Box Disassembly (See figure 4)

Drain the gear box by removing the gear box drain plug (14). Clean and reinstall the drain plug.

Remove the two hex head capscrews (15) and lock washers (16) securing the bearing housing (27) and cover plate (34) to the gear housing (3), and the five hex head capscrews (35) and lock washers (36) securing the cover plate to the gear housing.

Disengage the drive shaft (20) from the pinion gear (28), and remove the bearing housing, assembled cover plate, and assembled drive shaft and components.

Remove the two hex head capscrews (35) and lock washers (36) securing the cover plate to the bearing housing.

To disassemble the drive shaft components, remove the oil seal assembly (19) and washers (22), and press the drive shaft and assembled components out of the bearing housing. Remove the outboard snap ring (18), and remove the outboard bearing (23) and spacer sleeve (24). Remove the inboard bearing (25) and the inboard washer (17).



Remove the pinion shaft bushing (26), disengage the pinion gear from the cam shaft gear (32), and remove the pinion shaft (39) and assembled pinion gear. Remove the spacer washer (40) and the pinion gear. Press the pinion shaft bearing (41) out of the gear housing.

Remove the snap ring (6) securing the eccentric cam (9) on the eccentric cam shaft (7), and remove the eccentric cam, retaining the eccentric cam key (8). Remove the washer (10) and the eccentric cam shim set (5). Force the eccentric cam shaft and the remainder of the assembled components from the pump end of the gear housing out of the drive end.

To disassemble the cam shaft components, remove the snap ring (30), and remove the cam shaft gear, retaining the gear key (33). Remove the spacer washer (31), cam shaft bearings (4), and spacer (37).

PUMP ASSEMBLY REASSEMBLY

Gear Box Reassembly (See figure 4)

Clean all shafts and gears with a soft cloth soaked in cleaning solvent.

////////////////////
//
// **WARNING** //
// //
// Most cleaning solvents are toxic and flammable. Use //
// them only in a well-ventilated area free from ex- //
// cessive heat, sparks, and flame. Read and follow all //
// precautions printed on solvent containers. //
// //
////////////////////

Clean shaft sleeves, spacers, and the bores of the gear housing and bearing housing with a soft cloth soaked in cleaning solvent.

Clean all bearings in cleaning solvent free of grit or metallic particles.

Inspect all shafts, gears, and bearings, and replace as necessary.

Install the eccentric gear snap ring and the cam shaft gear key. Install the eccentric cam shaft gear, spacer washer, outboard bearing, spacer sleeve, and inboard bearing. Install the eccentric cam shaft and assembled components in the gear housing.

Install the eccentric cam washer and shim set. Install the eccentric cam and eccentric cam snap ring.

Install the pinion shaft bearing in the gear housing. Install the pinion shaft spacer washer. Install the pinion shaft in the shaft bearing, making certain that the shaft engages the eccentric cam shaft gear. Install the pinion gear and the pinion shaft bushing.

Install the inboard washer on the drive shaft, and install the drive shaft inboard bearing.

Install the spacer sleeve on the drive shaft, and install the drive shaft outboard bearing and the outboard snap ring.

Install the drive shaft and assembled bearings in the bearing housing.

Install the drive shaft washers. Inspect the oil seal assembly, and replace as necessary. Install the oil seal assembly with the lip positioned as shown in figure 4.

Replace the bearing housing gasket (29), and install the two capscrews and lock washers securing the cover plate to the bearing housing.

Replace the cover plate gasket (1), position the cover plate and the assembled bearing housing and drive shaft components on the dowel pins (38), and secure the cover plate and bearing housing to the gear housing, making certain that the pinion shaft bushing seats squarely in the bore of the bearing housing and that the drive shaft engages the pinion shaft gear.

Plunger Rod Reassembly (See figure 3)

Clean the plunger rod, and the bores of the eccentric, spacer, spring centering washer, and upper diaphragm plate with a soft cloth soaked in cleaning solvent.

Inspect the eccentric bearing, and replace as necessary. Install the bearing in the eccentric cap.

Inspect the plunger rod, and replace it if bent or warped. Install the plunger rod in the upper diaphragm plate. Install the flat washer and spring on the upper diaphragm plate, and install the spring washer, adjusting shims, and jam nut on the plunger rod.

Refer to figure 3, and tighten the jam nut until the spring is compressed to 4-7/8 inches. With the spring properly compressed, the distance between the bottom of the upper diaphragm plate and the top of the adjusting shims should measure 7-3/4 inches. Measure this distance, and add or remove adjusting shims until it is correct.

Install the T-lockwasher on the plunger rod, and screw the plunger rod into the eccentric cap until the cap and T-lockwasher are flush.

Inspect the diaphragm, and replace it if damaged or worn. Install the diaphragm on the lower diaphragm plate, and secure the lower diaphragm plate to the upper diaphragm plate.

Diaphragm Pot Reassembly (See figure 2)

Replace the inboard discharge flange gasket (22), and secure the inboard discharge flange to the diaphragm pot.

Inspect the discharge flap valve assembly and replace as necessary. Position the discharge flap valve assembly in the outboard discharge flange, install the valve seat, and secure the valve seat and discharge flap valve assembly to the outboard discharge flange.

Replace the outboard discharge flange gasket (22), and secure the outboard discharge flange to the inboard discharge flange.

Inspect the suction flap valve assembly and replace as necessary. Position the suction flap valve assembly in the diaphragm pot, install the valve seat, and secure the valve seat and suction discharge flap valve assembly to the diaphragm pot.

Replace the suction accumulator gasket (24), and secure the accumulator to the diaphragm pot.

Pump Assembly Reinstallation (See figure 1)

If the motor has not been removed, install the gear box drive shaft key in the shaft keyway, engage the drive shaft in the flexible coupling, and secure the gear box to the diaphragm ring.

Secure the coupling guard to the base.

Position the eccentric cap of the plunger rod assembly over the eccentric cam of the gear box assembly, and install the snap ring securing the plunger rod assembly.

Secure the diaphragm pot assembly to the diaphragm ring, making certain that the lip of the diaphragm is seated evenly between the diaphragm pot and the diaphragm ring.

Secure the eccentric guard assembly to the gearbox assembly.

MOTOR INSTALLATION (See figure 1)

Install the motor shaft key in the motor shaft keyway, engage the motor shaft in the flexible coupling, and secure the motor to the base.

Secure the coupling guard to the base.

LUBRICATION**Plunger Rod Assembly (See figure 3)****CAUTION**

The eccentric bearing (15) should be lubricated thoroughly after each 8 hours of operation. Failure to do so may cause the bearing to overheat and fail.

Lubricate the plunger rod assembly with Citgo #2 or equivalent automotive grease through the lubrication fittings (2 and 8), which are accessible through openings in the eccentric guard.

Apply sufficient grease to the upper lubrication fitting (2), so that grease escapes from the eccentric cap (1). Apply sufficient grease to the lower fitting (8) so that grease escapes from the top of the upper diaphragm plate (9).

Gear Box Assembly (See figure 4)

Remove the hex head capscrew (2), lockwasher (43), at the top of the gear box housing, and fill the oil cup (42) with a good grade of SAE 20-30 non-detergent motor oil to the midpoint of the oil cup sight gauge. Reinstall the hex head capscrew, flat washer, and lock washer.

OPERATION

Make certain that all piping connections are secure, and open all connecting valves.

See Section C for operation.

**For U.S. and International Warranty Information,
Please Visit www.grpumps.com/warranty
or call:
U.S.: 419-755-1280
International: +1-419-755-1352**

**For Canadian Warranty Information,
Please Visit www.grcanada.com/warranty
or call:
519-631-2870**