

**INSTALLATION, OPERATION,  
AND MAINTENANCE MANUAL**  
WITH PARTS LIST



PAH SERIES<sup>®</sup> PUMP

MODEL
<b>PAH4D60-QSB4.5P</b>

**GORMAN-RUPP PUMPS**

[www.grpumps.com](http://www.grpumps.com)

Register your new  
Gorman-Rupp pump online at  
**www.grpumps.com**

Valid serial number and e-mail address required.



**The engine exhaust from this product contains chemicals known to the State of California to cause cancer, birth defects or other reproductive harm.**

### **RECORD YOUR PUMP MODEL AND SERIAL NUMBER**

Please record your pump model and serial number in the spaces provided below. Your Gorman-Rupp distributor needs this information when you require parts or service.

Pump Model: \_\_\_\_\_

Serial Number: \_\_\_\_\_

# TABLE OF CONTENTS

<b>INTRODUCTION</b> .....	<b>PAGE I – 1</b>
<b>SAFETY - SECTION A</b> .....	<b>PAGE A – 1</b>
<b>INSTALLATION – SECTION B</b> .....	<b>PAGE B – 1</b>
Pump Dimensions .....	PAGE B – 1
<b>PREINSTALLATION INSPECTION</b> .....	<b>PAGE B – 1</b>
Battery Installation .....	PAGE B – 2
<b>POSITIONING PUMP</b> .....	<b>PAGE B – 2</b>
Lifting .....	PAGE B – 2
Mounting .....	PAGE B – 2
<b>SUCTION AND DISCHARGE PIPING</b> .....	<b>PAGE B – 3</b>
Materials .....	PAGE B – 3
Line Configuration .....	PAGE B – 3
Connections to Pump .....	PAGE B – 3
Gauges .....	PAGE B – 3
<b>SUCTION LINES</b> .....	<b>PAGE B – 3</b>
Fittings .....	PAGE B – 3
Strainers .....	PAGE B – 3
Sealing .....	PAGE B – 4
Suction Lines In Sumps .....	PAGE B – 4
Suction Line Positioning .....	PAGE B – 4
<b>DISCHARGE LINES</b> .....	<b>PAGE B – 5</b>
Siphoning .....	PAGE B – 5
Valves .....	PAGE B – 5
<b>ALIGNMENT</b> .....	<b>PAGE B – 5</b>
<b>AUTO-START</b> .....	<b>PAGE B – 5</b>
Float Switch Installation .....	PAGE B – 6
<b>COLD WEATHER INSTALLATION</b> .....	<b>PAGE B – 6</b>
<b>OPERATION – SECTION C</b> .....	<b>PAGE C – 1</b>
<b>OPERATION</b> .....	<b>PAGE C – 1</b>
<b>PRIMING</b> .....	<b>PAGE C – 1</b>
<b>STARTING</b> .....	<b>PAGE C – 1</b>
Manual Starting .....	PAGE C – 1
Automatic Starting .....	PAGE C – 2
Priming .....	PAGE C – 2
<b>ROUTINE OPERATION</b> .....	<b>PAGE C – 2</b>
<b>OPERATION IN EXTREME HEAT</b> .....	<b>PAGE C – 2</b>
<b>OPERATIONAL CHECKS</b> .....	<b>PAGE C – 3</b>
Leakage .....	PAGE C – 3
Pump Vacuum Check .....	PAGE C – 3
Liquid Temperature And Overheating .....	PAGE C – 3
Strainer Check .....	PAGE C – 3

**TABLE OF CONTENTS**  
**(continued)**

STOPPING .....	PAGE C – 3
Manual Stopping .....	PAGE C – 3
Automatic Stopping .....	PAGE C – 4
Safety Shutdown System .....	PAGE C – 4
PERIODIC CHECKS .....	PAGE C – 4
Seal Cavity and Bearing Lubrication .....	PAGE C – 4
Bearing Temperature Check .....	PAGE C – 4
Engine Fuel Filter .....	PAGE C – 4
Engine Oil .....	PAGE C – 5
Air Compressor .....	PAGE C – 5
COLD WEATHER PRESERVATION .....	PAGE C – 5
<b>TROUBLESHOOTING – SECTION D .....</b>	<b>PAGE D – 1</b>
PREVENTIVE MAINTENANCE .....	PAGE D – 3
<b>PUMP MAINTENANCE AND REPAIR - SECTION E .....</b>	<b>PAGE E – 1</b>
STANDARD PERFORMANCE CURVE .....	PAGE E – 1
PARTS LISTS:	
Pump Model .....	PAGE E – 3
Power Unit Kit .....	PAGE E – 5
Pump End Assembly .....	PAGE E – 7
Repair Rotating Assembly .....	PAGE E – 19
Priming Chamber Kit .....	PAGE E – 10
Priming Chamber Assembly .....	PAGE E – 11
Drive Assembly .....	PAGE E – 12
PUMP AND SEAL DISASSEMBLY AND REASSEMBLY .....	PAGE E – 13
Priming Chamber Removal And Disassembly .....	PAGE E – 14
Discharge Check Valve Removal and Disassembly .....	PAGE E – 14
Suction Head and Wear Ring Removal .....	PAGE E – 14
Pump Casing Removal .....	PAGE E – 15
Draining Oil From Seal Cavity .....	PAGE E – 15
Impeller Removal .....	PAGE E – 15
Seal Removal .....	PAGE E – 15
Separating Pedestal And Drive Assembly From Engine .....	PAGE E – 15
Shaft and Bearing Removal and Disassembly .....	PAGE E – 16
Shaft and Bearing Reassembly and Installation .....	PAGE E – 17
Securing Pedestal And Drive Assembly To Engine .....	PAGE E – 18
Seal Reassembly and Installation .....	PAGE E – 19
Impeller Installation And Adjustment .....	PAGE E – 20
Pump Casing Installation .....	PAGE E – 20
Suction Head And Wear Ring Installation .....	PAGE E – 20
Discharge Check Valve Reassembly And Installation .....	PAGE E – 20
Priming Chamber Assembly And Installation .....	PAGE E – 21
LUBRICATION .....	PAGE E – 21
Seal Assembly .....	PAGE E – 21
Bearings .....	PAGE E – 21
Engine .....	PAGE E – 21

## INTRODUCTION

**Thank You** for purchasing a Gorman-Rupp pump. **Read this manual** carefully to learn how to safely install and operate your pump. Failure to do so could result in personal injury or damage to the pump.

Because pump installations are seldom identical, this manual cannot possibly provide detailed instructions and precautions for every aspect of each specific application. Therefore, it is the responsibility of the owner/installer of the pump to ensure that applications not addressed in this manual are performed **only** after establishing that neither operator safety nor pump integrity are compromised by the installation. Pumps and related equipment **must** be installed and operated according to all national, local and industry standards.

If there are any questions regarding the pump or its application which are not covered in this manual or in other literature accompanying this unit, please contact your Gorman-Rupp distributor, or The Gorman-Rupp Company:

**The Gorman-Rupp Company**  
**P.O. Box 1217**  
**Mansfield, Ohio 44901—1217**  
**Phone: (419) 755—1011**  
 or:  
**Gorman-Rupp of Canada Limited**  
**70 Burwell Road**  
**St. Thomas, Ontario N5P 3R7**  
**Phone: (519) 631—2870**

For information or technical assistance on the power source, contact the power source manufacturer's local dealer or representative.

## HAZARD AND INSTRUCTION DEFINITIONS

The following are used to alert maintenance personnel to procedures which require special attention, to those which could damage equipment, and to those which could be dangerous to personnel:



**Immediate hazards which WILL result in severe personal injury or death. These instructions describe the procedure required and the injury which will result from failure to follow the procedure.**



**Hazards or unsafe practices which COULD result in severe personal injury or death. These instructions describe the procedure required and the injury which could result from failure to follow the procedure.**



Hazards or unsafe practices which COULD result in minor personal injury or product or property damage. These instructions describe the requirements and the possible damage which could result from failure to follow the procedure.

### NOTE

*Instructions to aid in installation, operation, and maintenance or which clarify a procedure.*

## SAFETY - SECTION A

This information applies to Prime Aire® Series pumps. Refer to the manual accompanying the engine or power source before attempting to begin operation.

Because pump installations are seldom identical, this manual cannot possibly provide detailed instructions and precautions for each specific application. Therefore, it is the owner/installer's responsibility to ensure that applications not addressed in this manual are performed only after establishing that neither operator safety nor pump integrity are compromised by the installation.



Before attempting to open or service the pump:

1. Familiarize yourself with this manual.
2. Shut down the engine and disconnect the positive battery cable to ensure that the pump will remain inoperative.
3. Allow the pump to completely cool if overheated.
4. Check the temperature and make sure the pump is cool before opening any covers, plates, or plugs.
5. Close the suction and discharge valves.
6. Vent the pump slowly and cautiously.
7. Drain the pump.



This pump is equipped with an automatic starting system, and is subject to automatic restart. Keep hands and clothing away from the unit to prevent injury during automatic operation. Disconnect

the positive battery cable before performing any maintenance. Failure to do so may result in serious personal injury.



Do not attempt to disengage any part of an overheated pump unit. Vapor pressure within the pump casing can eject these parts with great force when they are disengaged. Allow the pump to completely cool before servicing it.



This pump is designed to handle most non-volatile, non-flammable liquids containing specified entrained solids. Do not attempt to pump volatile, corrosive, or flammable liquids which may damage the pump or endanger personnel as a result of pump failure.



Death or serious personal injury and damage to the pump or components can occur if proper lifting procedures are not observed. Make certain that hoists, chains, slings or cables are in good working condition and of sufficient capacity and that they are positioned so that loads will be balanced and the pump or components will not be damaged when lifting. Suction and discharge hoses and piping must be removed from the pump before lifting. Lift the pump or component only as high as necessary and keep personnel away from suspended objects.



After the pump has been installed, make

certain that the pump and all piping or hose connections are tight, properly supported and secure before operation.



Do not operate the pump against a closed discharge valve. If operated against a closed discharge valve, pump components will deteriorate, and the liquid could come to a boil, build pressure, and cause the pump casing to rupture or explode. Momentary closure of a discharge valve is acceptable only when required for startup or shutdown procedures.



Do not remove plates, covers, gauges, pipe plugs, or fittings from an overheated pump. Vapor pressure within the pump can cause parts being disengaged to be ejected with great force. Allow the pump to cool completely before servicing.



This pump may be used to handle materials which could cause illness through direct exposure or emitted fumes. Wear adequate protective clothing when working on the pump or piping.



Do not operate the pump without guards in place over the rotating parts. Exposed rotating parts can catch clothing,

fingers or tools, causing severe injury to personnel.

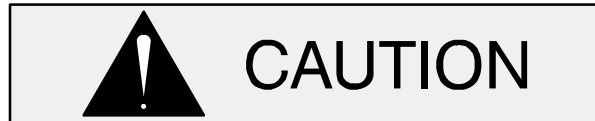

Make sure the pump is level. Lower jack stands and chock the wheels, if so equipped. Use caution when positioning the skid-mounted unit to prevent damage to the fuel tank.



Do not operate an internal combustion engine in an explosive atmosphere. When operating an internal combustion engine in an enclosed area, make sure exhaust fumes are piped to the outside. These fumes contain carbon monoxide, a deadly gas that is colorless, tasteless and odorless.



Fuel used by internal combustion engines presents an extreme explosion and fire hazard. Make certain that all fuel lines are securely connected and free of leaks. Never refuel a hot or running engine. Avoid overfilling the fuel tank. Always use the correct type of fuel.



Never tamper with the governor to gain more power. The governor establishes safe operating limits that should not be exceeded. Refer to the performance curve on page E-1 for the maximum continuous operating speed for this pump.

## INSTALLATION – SECTION B

### Review all SAFETY information in Section A.

Since pump installations are seldom identical, this section offers only general recommendations and practices required to inspect, position, and arrange the pump and piping.

Most of the information pertains to a standard **static lift** application where the pump is positioned above the free level of liquid to be pumped.

If installed in a **flooded suction application** where the liquid is supplied to the pump under pressure, some of the information such as mounting, line

configuration, and priming must be tailored to the specific application. Since the pressure supplied to the pump is critical to performance and safety, **be sure** to limit the incoming pressure to 50% of the maximum permissible operating pressure as shown on the pump performance curve.

For further assistance, contact your Gorman-Rupp distributor or the Gorman-Rupp Company.

### Pump Dimensions

See Figure 1 for the approximate physical dimensions of this pump.

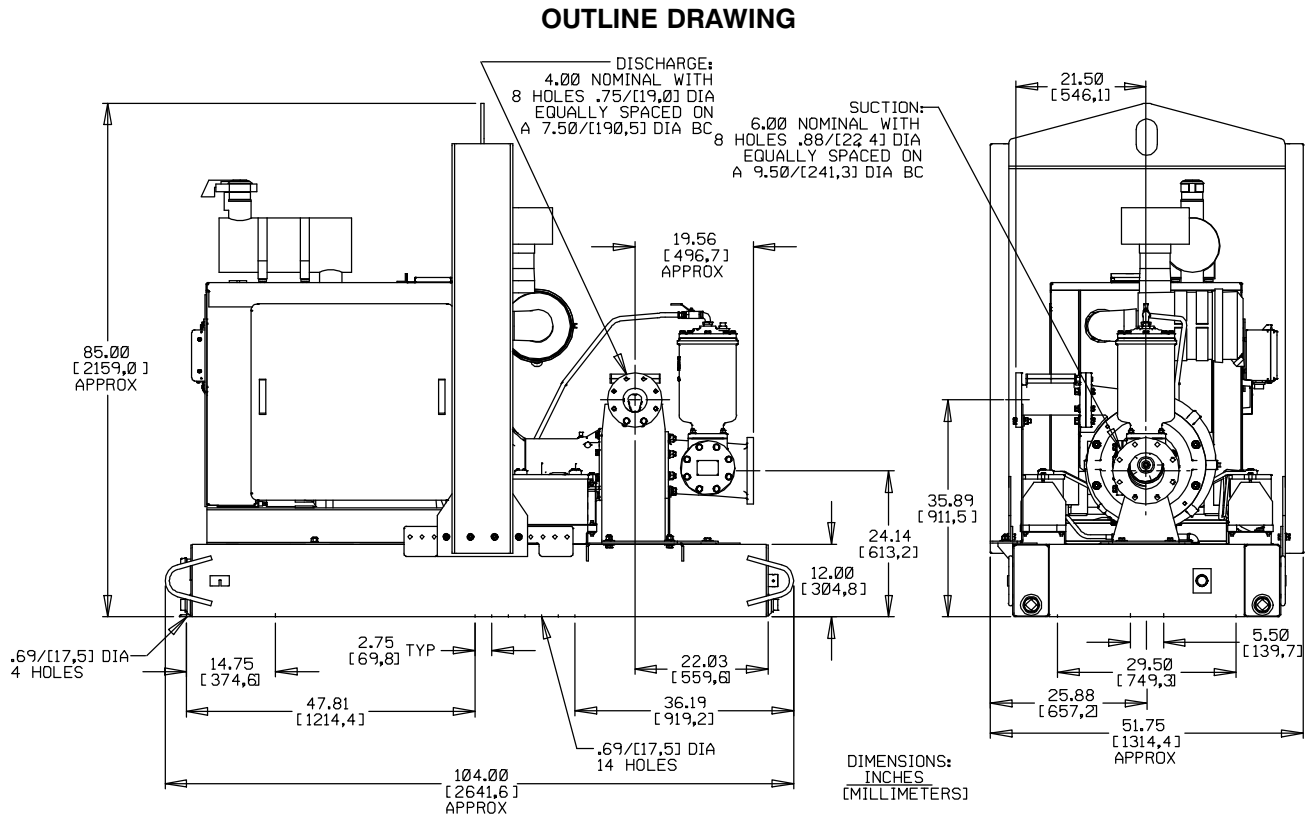

**Figure 1. Pump Model PAH4D60-QSB4.5P**

### PREINSTALLATION INSPECTION

The pump assembly was inspected and tested before shipment from the factory. Before installation, inspect the pump for damage which may have occurred during shipment. Check as follows:

- a. Inspect the pump for cracks, dents, damaged threads, and other obvious damage.
- b. Check for and tighten loose attaching hardware. Since gaskets tend to shrink after drying, check for loose hardware at mating surfaces.



- c. Carefully read all tags, decals, and markings on the pump assembly, and perform all duties indicated. Note that the pump shaft rotates in the required direction.

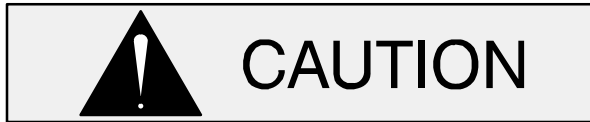

Only operate this pump in the direction indicated by the arrow on the pump body and on the accompanying decal. Otherwise, the impeller could become loosened from the shaft and seriously damage the pump.

- d. Check levels and lubricate as necessary. Refer to **LUBRICATION** in the **Maintenance and Repair Manual** and perform duties as instructed.
- e. If the pump has been stored for more than 12 months, some of the components or lubricants may have exceeded their maximum shelf life. These **must be inspected or replaced** to ensure maximum pump service.

If the maximum shelf life has been exceeded, or if anything appears to be abnormal, contact your Gorman-Rupp distributor or the factory to determine the repair or updating policy. **Do not** put the pump into service until appropriate action has been taken.

### Battery Installation

Unless otherwise specified on the pump order, the engine battery is **not** included with engine driven units.

Refer to the information accompanying the battery and/or electrolyte solution for activation and charging instructions.

Before installing the battery, clean the positive and negative cable connectors, and the battery terminals. Secure the battery by tightening the holddown brackets. The terminals and clamps may be coated with petroleum jelly to retard corrosion. Connect and tighten the positive cable first, then the negative cable.

## POSITIONING PUMP

### Lifting



**Death or serious personal injury and damage to the pump or components can occur if proper lifting procedures are not observed. Make certain that hoists, chains, slings or cables are in good working condition and of sufficient capacity and that they are positioned so that loads will be balanced and the pump or components will not be damaged when lifting. Suction and discharge hoses and piping must be removed from the pump before lifting. Lift the pump or component only as high as necessary and keep personnel away from suspended objects.**

Pump unit weights will vary depending on the mounting and drive provided. Check the shipping tag on the unit packaging for the actual weight, and use lifting equipment with appropriate capacity. Drain the pump and remove all customer-installed equipment such as suction and discharge hoses or piping before attempting to lift existing, installed units.

### Mounting

Locate the pump in an accessible place as close as practical to the liquid being pumped. Level mounting is essential for proper operation. The pump may have to be supported or shimmed to provide for level operation and eliminate vibration.

For engine driven units, the pump **must** be positioned as level as possible to ensure sufficient lubrication and fuel supply to the engine.



If your pump is equipped with optional oil lubricated bearings, level mounting is essential to ensure sufficient lubrication to the pump bearings. Damage to the pump,

including the bearings, shaft and/or bearing housing may occur if the pump is operated for an extended period of time on an unlevel surface. To ensure sufficient lubrication, never operate a unit equipped with oil lubricated bearings at an angle greater than 2° off level.

If the pump has been mounted on a moveable base, make certain the base is stationary by setting the brake and blocking the wheels before attempting to operate the pump.



**If the pump has been mounted on a moveable base, do not attempt to operate the pump unless the unit is level. Be sure the leveling stands are positioned on a solid surface, and the wheels are chocked.**

## SUCTION AND DISCHARGE PIPING

Pump performance is adversely effected by increased suction lift, discharge elevation, and friction losses. See the performance curve and operating range shown on Page E-1 to be sure your overall application allows pump to operate within the safe operation range.

### Materials

Either pipe or hose maybe used for suction and discharge lines; however, the materials must be compatible with the liquid being pumped. If hose is used in suction lines, it must be the rigid-wall, reinforced type to prevent collapse under suction. Using piping couplings in suction lines is not recommended.

### Line Configuration

Keep suction and discharge lines as straight as possible to minimize friction losses. Make minimum use of elbows and fittings, which substantially increase friction loss. If elbows are necessary, use the long-radius type to minimize friction loss.

## Connections to Pump

Before tightening a connecting flange, align it exactly with the pump port. Never pull a pipe line into place by tightening the flange bolts and/or couplings.

Lines near the pump must be independently supported to avoid strain on the pump which could cause excessive vibration, decreased bearing life, and increased shaft and seal wear. If hose-type lines are used, they should have adequate support to secure them when filled with liquid and under pressure.

## Gauges

The pump is drilled and tapped for installing discharge pressure and vacuum suction gauges. It is recommended that gauges be installed to monitor pump performance. Seal the gauge threads with pipe dope to ensure an airtight seal. Follow the sealant manufacturer's recommendations when selecting and applying the pipe dope. The pipe dope should be compatible with the liquid being pumped.

## SUCTION LINES

To avoid air pockets which could affect pump priming, the suction line must be as short and direct as possible. When operation involves a suction lift, the line must always slope upward to the pump from the source of the liquid being pumped; if the line slopes down to the pump at any point along the suction run, air pockets will be created.

## Fittings

Suction lines should be the same size as the pump inlet. If reducers are used in suction lines, they should be the eccentric type, and should be installed with the flat part of the reducers uppermost to avoid creating air pockets. Valves are not normally used in suction lines, but if a valve is used, install it with the stem horizontal to avoid air pockets.

## Strainers

Be certain to use the strainer furnished with the pump; any spherical solids which pass through the strainer will also pass through the pump itself.

If a strainer not furnished with the pump is installed by the pump user, make certain that the total area of the openings in the strainer is at least three or four times the cross section of the suction line, and that the openings will not permit passage of solids larger than the solids handling capability of the pump.

This pump is designed to handle up to 1/2 inch (12,7 mm) diameter spherical solids.

### Sealing

Since even a slight leak will affect priming, head, and capacity, especially when operating with a high suction lift, all connections in the suction line should be sealed with pipe dope to ensure an air-tight seal. Follow the sealant manufacturer's recommendations when selecting and applying the pipe dope. The pipe dope should be compatible with the liquid being pumped.

### Suction Lines In Sumps

If a single suction line is installed in a sump, it should be positioned away from the wall of the sump at a distance equal to 1 1/2 times the diameter of the suction line.

If there is a liquid flow from an open pipe into the sump, the flow should be kept away from the suction inlet because the inflow will carry air down into the sump, and air entering the suction line will reduce pump efficiency.

If it is necessary to position inflow close to the suction inlet, install a baffle between the inflow and the suction inlet at a distance 1-1/2 times the diameter of the suction pipe. The baffle will allow entrained air to escape from the liquid before it is drawn into the suction inlet.

If two suction lines are installed in a single sump, the flow paths may interact, reducing the efficiency of one or both pumps. To avoid this, position the suction inlets so that they are separated by a distance equal to at least 3 times the diameter of the suction pipe.

### Suction Line Positioning

The depth of submergence of the suction line is critical to **efficient** pump operation. Figure 2 shows recommended minimum submergence vs. velocity.

Although not recommended, the vacuum assisted priming feature allows the pump to be operated temporarily in a "slurping" application with varying water levels.

### NOTE

*The pipe submergence required may be reduced by installing a standard pipe increaser fitting at the end of the suction line. The larger opening size will reduce the inlet velocity. Calculate the required submergence using the following formula based on the increased opening size (area or diameter).*



Figure 2. Recommended Minimum Suction Line Submergence vs. Velocity

**DISCHARGE LINES**

**Siphoning**

Do not terminate the discharge line at a level lower than that of the liquid being pumped unless a siphon breaker is used in the line. Otherwise, a siphoning action causing damage to the pump could result.

**Valves**

This pump is designed with a check valve in the discharge line.

If a throttling valve is desired in the discharge line, use a valve as large as the largest pipe to minimize friction losses. Never install a throttling valve in a suction line.

With high discharge heads, it is recommended that a throttling valve be installed in the discharge line to protect the pump from excessive shock pressure and reverse rotation when it is stopped.



If the application involves a high discharge head, gradually close the discharge throttling valve before stopping the pump.

**ALIGNMENT**

The alignment of the pump, air compressor and engine is critical for trouble-free mechanical operation. See Section E, **Securing Intermediate And Drive Assembly To Engine** in **MAINTENANCE AND REPAIR**, for details.

**AUTO-START**

The standard pump is equipped with an auto-start control system which allows the pump to start and stop as the liquid level in the wet well or sump rises and falls.

Refer to the information which follows for installation details for the liquid level sensing system provided with your pump.

### Float Switch Installation

The Float Switch autostart system employs either a single or double float switch, where a bulb raises or lowers (floats) with the liquid level, thus activating an enclosed miniature switch. The floats are equipped with a socket type connector that plugs into a matching receptacle on the auto-start control box.

Standard floats are equipped with 50 feet (15,2 m) of cable.

When installing the floats, note the following:

- a. **Be sure** to provide sufficient room in the wet well or sump so that floats do not get obstructed or drawn into the suction line. If a flexible suction hose is used, it may be extended to lay along the bottom of the wet well or sump and the float can be attached to the hose above the point where it bends along the bottom. Direct the suction line toward the flow, and the float(s) away from the flow. If a stand-

pipe is available, attach the float switch cable to the standpipe in the sump at the approximate desired liquid level.

- b. In a single float system, the cable can be tethered to the suction line or standpipe approximately 6 inches (152 mm) above the float. This setting allows approximately 9 inches (229 mm) of liquid rise between pump start/stop. The start/stop interval may be increased by extending the float end of the cable. The liquid level in the sump will increase approximately 8 inches (203 mm) between start/stop intervals for every 6 inches (152 mm) of cable increase.
- c. If a double float switch system is used, position the "Start" float at the desired high water level in the sump, and the "Stop" float at the desired low water level in the pump.
- d. Refer to Figure 3 for additional float switch data.

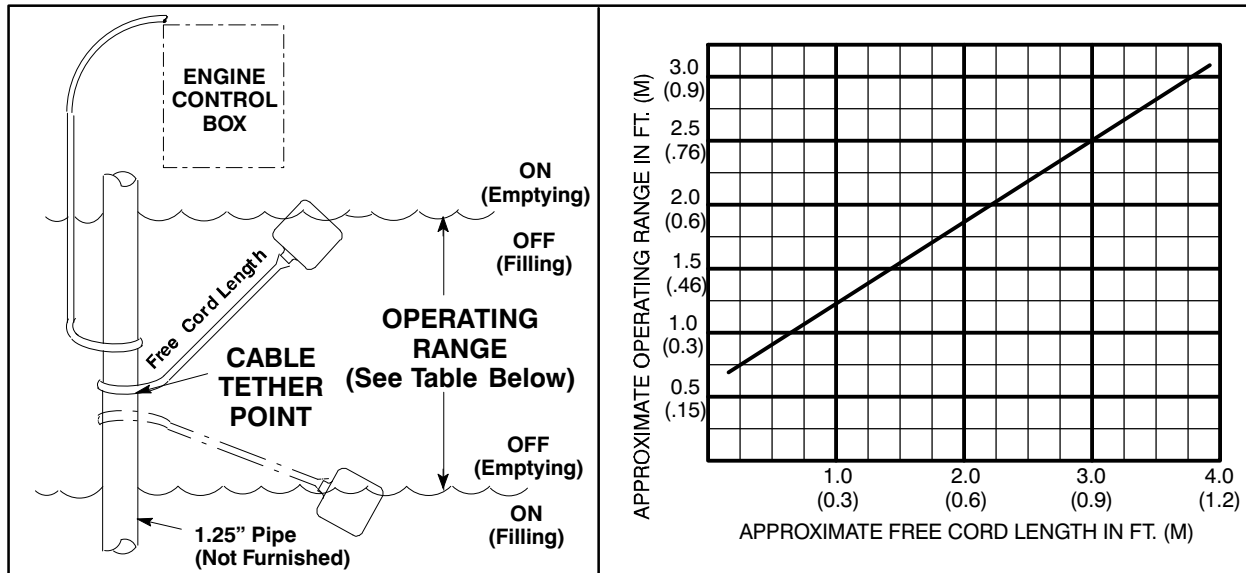

Figure 3. Float Switch Data

### COLD WEATHER INSTALLATION

If the pump is to be installed in an environment where sub-freezing temperatures will occur during operation, consideration must be given to prevent the pump and components from freezing when the pump is idle between pumping cycles. With Gorman-Rupp priming assisted pumps, there are two methods of accomplishing this.

One method is through the use of an optional heated priming chamber, which is available as a factory-installed option or as a retrofit kit for most models (consult the factory). This method pumps heated liquid from the engine cooling system through the priming chamber to heat the chamber and its contents. This method is particularly effective where pumping cycles are short enough to ensure

that the liquid in the priming chamber never fully freezes.

The second method involves configuring the pumping system to drain both the priming chamber and pump casing after each pumping cycle. With no liquid remaining in the system, freezing cannot occur.

To configure the pump to drain between pumping cycles, the first step is to remove the check valve from the line that runs between the top of the priming hopper and the priming venturi. This check valve is located close to the venturi end of the line. Remove the check valve, then reconnect the line directly to the venturi. This will allow air to enter the pump through the top of the priming hopper when the pump shuts off, providing for complete drainage of the pump and priming hopper.

Next, install a drain line between the pump drain and the wet well or sump. This line must remain submerged in the liquid below the pump down level of the liquid level control device; otherwise, the pump may not prime. If the application involves liquids that could clog the drain line, make sure to check the line periodically to ensure it remains open; otherwise, liquid could remain in the casing, resulting in freezing and potential damage to the pumping system.

Configuring the system to drain between cycles will help ensure that the pump will not freeze during cold weather applications. **However, it should be noted that the time required for the pump to begin to discharge liquid will increase, as the pump will have to fully re-prime at the beginning of each pumping cycle.**

## OPERATION – SECTION C

Review all **SAFETY** information in Section A.

Follow the instructions on all tags, labels and decals attached to the pump.



**Do not operate an internal combustion engine in an explosive atmosphere. When operating an internal combustion engine in an enclosed area, make sure exhaust fumes are piped to the outside. These fumes contain carbon monoxide, a deadly gas that is colorless, tasteless and odorless.**

### OPERATION



**This pump is designed to handle most non-volatile, non-flammable liquids containing specified entrained solids and corrosives. Do not attempt to pump volatile, corrosive, or flammable liquids which may damage the pump or endanger personnel as a result of pump failure.**



Pump speed and operating condition points must be within the continuous performance range shown on the performance curve in Section E on page E-1.

### PRIMING

Install the pump and piping as described in **INSTALLATION**. Make sure that the piping connections are tight, and that the pump is securely mounted. Check that the pump is properly lubri-

cated (see **LUBRICATION** in **MAINTENANCE AND REPAIR**).

The pump will begin to prime upon startup. The air in the suction line will be discharged from the educator discharge line. Complete priming is indicated by a positive discharge pressure reading.

If full priming is not achieved, the discharge check valve may be malfunctioning. If this occurs, shut down the pump and consult **Maintenance and Repair**, Section E for further details.

### STARTING

Check the fuel level and oil levels in the engine, air compressor, pump bearings and seal housing.

Make sure the pump is level. Lower the jack stands and chock the wheels, if so equipped.



Make sure the pump is level. Lower jack stands and chock the wheels, if so equipped. Use caution when positioning the skid-mounted unit to prevent damage to the fuel tank.



**This pump is equipped with automatic liquid level controls, and is subject to automatic restart. Keep hands and clothing away from the unit to prevent injury during automatic operation. Disconnect the positive battery cable before performing any maintenance. Failure to do so may result in serious personal injury.**

Consult the engine operations manual before attempting to start the unit.

### Manual Starting

On initial start-up, set the engine speed at the half-throttle position. Turn the key switch on the control

box to the “MANUAL” position, then press and hold the “ENTER” button until the engine starts.

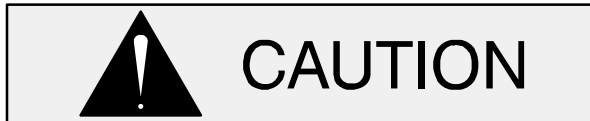

Pump speed and operating condition points must be within the continuous performance range shown on the curve on Page E-1.

### Automatic Starting

With the float system installed, follow the procedures outlined for manual starting and adjust the throttle to the desired flow rate. Turn the key switch to “OFF”, then move it to the “AUTO” position.

The pump will start automatically when the liquid level in the sump or wet well increases and the float(s) rise to the “on” position. An alarm will sound and the control box will begin a countdown display before the unit starts. When the liquid is sufficiently pumped down, the unit will automatically shut down.

The unit can be stopped while in the “AUTO” mode by moving the key switch to the “OFF” position.

### NOTE

*If the key switch is moved to the “OFF” position while in the “AUTO” mode, the engine will stop. However, the auto-start process will continue as soon as the key switch is moved back to the “AUTO” position.*

The control panel is equipped with high oil temperature, low oil pressure, engine overspeed and engine overcrank safety shutdowns. If any of these problems occur, the engine will not start. When the problem is corrected, turn the key switch to the “OFF” position to reset the control.

### Priming

The pump will begin to prime upon startup. The air in the suction line will be discharged from the educator discharge line. Complete priming is indicated by a positive discharge pressure reading.

If full priming is not achieved, the discharge check valve may be malfunctioning. If this occurs, shut down the pump and consult the separate **Maintenance and Repair** manual for further details.

### Routine Operation



**Do not operate an internal combustion engine in an explosive atmosphere. When operating an internal combustion engine in an enclosed area, make sure exhaust fumes are piped to the outside. These fumes contain carbon monoxide, a deadly gas that is colorless, tasteless and odorless.**

Adjust the engine speed to achieve the desired output. Do not exceed the factory set engine speed and system operating pressure. Do not operate below the recommended operating speed (if applicable).



**Never tamper with the governor to gain more power. The governor establishes safe operating limits that should not be exceeded. Refer to the performance curve on page E-1 for the maximum continuous operating speed for this pump.**

### Operation In Extreme Heat

The safety shutdown system will automatically stop the unit if engine operating temperature exceeds design limits. If engine over-temperature shutdown occurs, allow the unit to cool before re-starting.

If engine overheating continues, check the engine lubricant level and viscosity. Consult the engine operation manual for the recommended lubricant for operation in extreme heat.

If the unit is being operated in the **automatic** mode, adjust the float(s) to allow shorter run and longer cooling periods, if possible.





This pump is equipped with automatic liquid level controls, and is subject to automatic restart. Keep hands and clothing away from the unit to prevent injury during automatic operation. Disconnect the battery before performing any maintenance. Failure to do so may result in serious personal injury.

## OPERATIONAL CHECKS

### Leakage

Once the pump is fully primed, no leakage should be visible at pump mating surfaces, or at pump connections or fittings. Keep all line connections and fittings tight to maintain maximum pump efficiency.

### Pump Vacuum Check

Read the vacuum gauge with the pump primed and at operation speed. Shut off the pump. The vacuum gauge reading will immediately drop proportionate to static suction lift, and should then stabilize. If the vacuum reading falls off rapidly after stabilization, an air leak exists. Before checking for the source of the leak, check the point of installation of the vacuum gauge.

### Liquid Temperature And Overheating

The **maximum** liquid temperature for this pump is 160°F (71°C). Do not apply it at a higher operating temperature.

Overheating can occur if operated with the valves in the suction or discharge lines closed. Operating against closed valves could bring the liquid to a boil, build pressure, and cause the pump to rupture or explode. If overheating occurs, stop the pump immediately and allow it to completely cool before servicing it. **Approach any over-heated pump cautiously.**



Allow an over-heated pump to completely cool before servicing. Do not remove plates, covers, gauges, or fittings from an overheated pump. Liquid within the pump can reach boiling temperatures, and vapor pressure within the pump can cause parts being disengaged to be ejected with great force. After the pump cools, drain the liquid from the pump by removing the casing drain plug. Use caution when removing the plug to prevent injury to personnel from hot liquid.

### Strainer Check

Check the strainer regularly, and clean it as necessary. The strainer should also be checked if pump flow rate begins to drop. Monitor and record the vacuum suction gauge readings regularly to detect strainer blockage.

**Never** introduce air or steam pressure into the pump casing or piping to remove a blockage. This could result in personal injury or damage to the equipment. If backflushing is absolutely necessary, **liquid pressure** must be limited to 50% of the maximum permissible operating pressure shown on the pump performance curve.

## STOPPING

### Manual Stopping

Never halt the flow of liquid suddenly. If the liquid being pumped is stopped abruptly, damaging shock waves can be transmitted to the pump and piping system. Close all connecting valves slowly.

In the manual mode, reduce the throttle speed slowly, and allow the engine to idle briefly before switching the engine key switch to 'OFF'.



If the application involves a high discharge head, gradually close the discharge throttling valve before stopping the pump.

After stopping the pump, switch off the engine ignition and remove the key to ensure that the pump will remain inoperative.

### Automatic Stopping

In the automatic mode, the pump will stop when the liquid in the wet well or sump lowers and activates the "Off" float switch(s). The pump will restart automatically when the liquid rises and activates the "On" float switch(s).

### Safety Shutdown System

The unit is equipped with a safety system to automatically shut down the engine under certain conditions. The engine will automatically shut down:

1. If the engine exceeds its safe operating temperature.
2. If the engine oil pressure drops below design limits.
3. If the engine fails to start within a pre-set period of time.
4. If the engine speed exceeds the safe operating range.
5. If the engine fan belt breaks.

Lights on the control panel will indicate which of the safety features has caused the engine to shut down.

Should any of the safety features cause the engine to shut down, **the cause must be determined and corrected** before putting the unit back into service. The engine **will not restart** until the key switch has been returned to the 'OFF' position for at least 10 seconds.

All safety shutdown features are pre-set at the factory for optimum performance and safety; **do not** attempt to adjust these settings.



**Never disconnect any of the safety shutdown features; this will void the warranty and could result in serious damage to**

**the unit and/or injury to personnel. Safety shutdown features are pre-set at the factory; do not attempt to adjust any of the settings. Determine the cause of shutdown before putting the unit back into service. Consult the factory for additional information.**

## PERIODIC CHECKS

### Seal Cavity And Bearing Lubrication

Both the seal and bearing cavities were fully lubricated at the factory. Check the lubrication levels before startup, and regularly thereafter as indicated in Section E, **Maintenance and Repair**. When lubrication is required, use **only** SAE No. 30 non-detergent oil.

### Bearing Temperature Check

Bearings normally run at higher than ambient temperatures because of heat generated by friction. Temperatures up to 160°F (71°C) are considered normal for bearings, and they can operate safely to at least 180°F (82°C).

Checking bearing temperatures by hand is inaccurate. Bearing temperatures can be measured accurately by placing a contact-type thermometer against the housing. Record this temperature for future reference.

A sudden increase in bearing temperatures is a warning that the bearings are at the point of failing to operate properly. Make certain that the bearing lubricant is of the proper viscosity and at the correct level (see **LUBRICATION** in Section E, **Maintenance and Repair**). Bearing overheating can also be caused by shaft misalignment and/or excessive vibration.

When pumps are first started, the bearings may seem to run at temperatures above normal. Continued operation should bring the temperatures down to normal levels.

### Engine Fuel Filter

Consult the manual accompanying the engine, and change the fuel filter periodically as indicated. If operated under extremely dusty and/or humid

conditions, change the filter more frequently. Irregular performance and loss of power usually indicate a dirty fuel filter.

### Engine Oil

The engine was lubricated for test at the factory. However, **always** check the lubrication level before startup.

Consult the manual accompanying the engine, and change the oil filter periodically as indicated. If operated under extremely dusty conditions, change the filter more frequently.

### Air Compressor

The air compressor was lubricated for test at the factory. However, **always** check the lubrication level before startup.

Consult the manual accompanying the air compressor and perform all duties and checks as indicated.

## COLD WEATHER PRESERVATION

If the pump will be idle for an extended period of time in below freezing conditions, drain the pump and priming hopper to prevent damage from freezing. Also, clean out any solids by flushing with a hose. Operate the pump for approximately one minute; this will remove any remaining liquid that could freeze the pump rotating parts. If the pump will be idle for more than a few hours, or if it has been pumping liquids containing a large amount of solids, drain the pump, and flush it thoroughly with clean water. To prevent large solids from clogging the drain port and preventing the pump from completely draining, insert a rod or stiff wire in the drain port, and agitate the liquid during the draining process. Clean out any remaining solids by flushing with a hose.

If the pump is to be installed in an environment where sub-freezing temperatures will occur during operation, consideration must be given to prevent the pump and components from freezing when the pump is idle between pumping cycles. Refer to **COLD WEATHER INSTALLATION** in the **Installation** section of this manual for details.

## TROUBLESHOOTING – SECTION D

Review all SAFETY information in Section A.



Before attempting to open or service the pump:

1. Familiarize yourself with this manual.
2. Shut down the engine and disconnect the positive battery cable to ensure that the pump will remain inoperative.
3. Allow the pump to completely cool if overheated.
4. Check the temperature before opening any covers, plates, or plugs.

5. Close the suction and discharge valves.
6. Vent the pump slowly and cautiously.
7. Drain the pump.



This pump is equipped with an automatic starting system, and is subject to automatic restart. Keep hands and clothing away from the unit to prevent injury during automatic operation. Disconnect the positive battery cable before performing any maintenance. Failure to do so may result in serious personal injury.

TROUBLE	POSSIBLE CAUSE	PROBABLE REMEDY
PUMP FAILS TO PRIME	Discharge check valve contaminated, damaged, or unable to seat. Air leak in suction line. Lining of suction hose collapsed. Leaking or worn seal or pump gasket.  Suction lift or discharge head too high.  Air compressor damaged or belts broken. Strainer clogged.	Clean or replace check valve.  Correct leak. Replace suction hose. Check pump vacuum. Replace leaking or worn seal or gasket. Check piping installation and install bypass line if needed. See <b>INSTALLATION</b> . Check and repair/replace.  Check strainer and clean if necessary.
PUMP STOPS OR FAILS TO DELIVER RATED FLOW OR PRESSURE	Eductor clogged. Air leak in suction line. Lining of suction hose collapsed. Leaking or worn seal or pump gasket.	Check and clean eductor. Correct leak. Replace suction hose. Check pump vacuum. Replace leaking or worn seal or gasket.

TROUBLE	POSSIBLE CAUSE	PROBABLE REMEDY
PUMP STOPS OR FAILS TO DELIVER RATED FLOW OR PRESSURE (cont.)	<p>Strainer clogged.</p> <p>Discharge check valve clogged.</p> <p>Suction intake not submerged at proper level or sump too small.</p> <p>Impeller or other wearing parts worn or damaged.</p> <p>Impeller clogged.</p> <p>Discharge head too high.</p> <p>Suction lift too high.</p> <p>Pump speed too slow.</p> <p>Belt or flexible coupling broken.</p>	<p>Check strainer and clean if necessary.</p> <p>Check and clean check valve.</p> <p>Check installation and correct submergence as needed.</p> <p>Replace worn or damaged parts. Check that impeller is properly centered and rotates freely.</p> <p>Free impeller of debris.</p> <p>Install bypass line.</p> <p>Measure lift w/vacuum gauge. Reduce lift and/or friction losses in suction line.</p> <p>Check engine output; consult engine operation manual.</p> <p>Check and replace as necessary.</p>
PUMP REQUIRES TOO MUCH POWER	<p>Pump speed too high.</p> <p>Extreme ambient temperature.</p> <p>Discharge head too low.</p> <p>Fuel filter clogged.</p> <p>Liquid solution too thick.</p> <p>Fuel contaminated.</p> <p>Pump or jack shaft bearing(s) frozen.</p>	<p>Check engine output.</p> <p>Reduce pump output.</p> <p>Adjust discharge valve.</p> <p>Check &amp; replace often in extreme operating conditions.</p> <p>Dilute if possible.</p> <p>Check and replace as required.</p> <p>Disassemble, check and replace bearing(s) as required..</p>
PUMP CLOGS FREQUENTLY	<p>Discharge flow too slow.</p> <p>Suction check valve or foot valve clogged or binding.</p> <p>Liquid solution too thick.</p>	<p>Open discharge valve fully to increase flow rate, and run engine at maximum governed speed.</p> <p>Clean valve.</p> <p>Dilute if possible.</p>
EXCESSIVE NOISE	<p>Cavitation in pump.</p> <p>Pumping entrained air.</p> <p>Pump or drive not securely mounted.</p> <p>Impeller clogged or damaged.</p>	<p>Reduce suction lift and/or friction losses in suction line. Record vacuum and pressure gauge readings and consult local representative or factory.</p> <p>Locate and eliminate source of air bubble.</p> <p>Secure mounting hardware.</p> <p>Clean out debris; replace damaged parts.</p>

TROUBLE	POSSIBLE CAUSE	PROBABLE REMEDY
BEARINGS RUN TOO HOT	<p>Bearing temperature is high, but within limits.</p> <p>Low or incorrect lubricant.</p> <p>Suction and discharge lines not properly supported.</p> <p>Drive misaligned.</p> <p>Excessive tension on drive belt.</p>	<p>Check bearing temperature regularly to monitor any increase.</p> <p>Check for proper type and level of lubricant.</p> <p>Check piping installation for proper support.</p> <p>Align drive properly.</p> <p>Check belt tension. Adjust as required.</p>

## PREVENTIVE MAINTENANCE

Since pump applications are seldom identical, and pump wear is directly affected by such things as the abrasive qualities, pressure and temperature of the liquid being pumped, this section is intended only to provide general recommendations and practices for preventive maintenance. Regardless of the application however, following a routine preventive maintenance schedule will help assure trouble-free performance and long life from your Gorman-Rupp pump. For specific questions concerning your application, contact your Gorman-Rupp distributor or the Gorman-Rupp Company.

Record keeping is an essential component of a good preventive maintenance program. Changes in suction and discharge gauge readings (if so

equipped) between regularly scheduled inspections can indicate problems that can be corrected before system damage or catastrophic failure occurs. The appearance of wearing parts should also be documented at each inspection for comparison as well. Also, if records indicate that a certain part (such as the seal) fails at approximately the same duty cycle, the part can be checked and replaced before failure occurs, reducing unscheduled down time.

For new applications, a first inspection of wearing parts at 250 hours will give insight into the wear rate for your particular application. Subsequent inspections should be performed at the intervals shown on the chart below. Critical applications should be inspected more frequently.

<b>Preventive Maintenance Schedule</b>					
Item	Service Interval*				
	Daily	Weekly	Monthly	Semi-Annually	Annually
General Condition (Temperature, Unusual Noises or Vibrations, Cracks, Leaks, Loose Hardware, Etc.)	I				
Pump Performance (Gauges, Speed, Flow)	I				
Bearing Lubrication		I			R
Seal Lubrication (And Packing Adjustment, If So Equipped)		I			R
V-Belts (If So Equipped)			I		
Air Release Valve Plunger Rod (If So Equipped)			I	C	
Front Impeller Clearance (Wear Plate)				I	
Rear Impeller Clearance (Seal Plate)				I	
Check Valve					I
Pressure Relief Valve (If So Equipped)					C
Pump and Driver Alignment					I
Shaft Deflection					I
Bearings					I
Bearing Housing					I
Piping					I
Driver Lubrication – See Mfgr’s Literature					I

Legend:  
 I = Inspect, Clean, Adjust, Repair or Replace as Necessary  
 C = Clean  
 R = Replace

\* Service interval based on an intermittent duty cycle equal to approximately 4000 hours annually. Adjust schedule as required for lower or higher duty cycles or extreme operating conditions.

## PUMP MAINTENANCE AND REPAIR – SECTION E

MAINTENANCE AND REPAIR OF THE WEARING PARTS OF THE PUMP WILL MAINTAIN PEAK OPERATING PERFORMANCE.

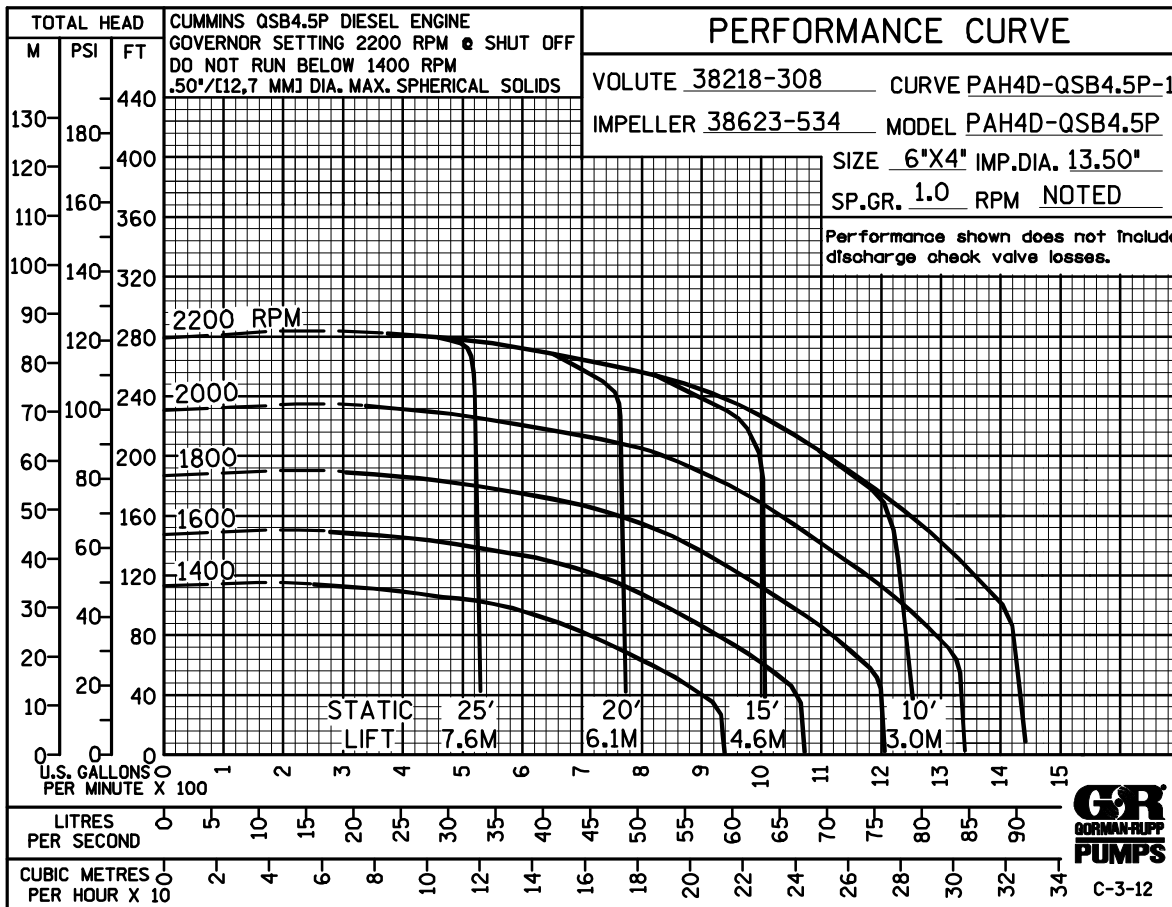

**\* STANDARD PERFORMANCE FOR PUMP MODEL PAH4D60-QSB4.5P**

\* Based on 70°F (21°C) clear water at sea level with minimum suction lift. Since pump installations are seldom identical, your performance may be different due to such factors as viscosity, specific gravity, elevation, temperature, and impeller trim.

Contact the Gorman-Rupp Company to verify performance or part numbers.



CAUTION

Pump speed and operating condition points must be within the continuous performance range shown on the curve.

If your pump serial number is followed by an "N", your pump is **NOT** a standard production model.



ILLUSTRATION

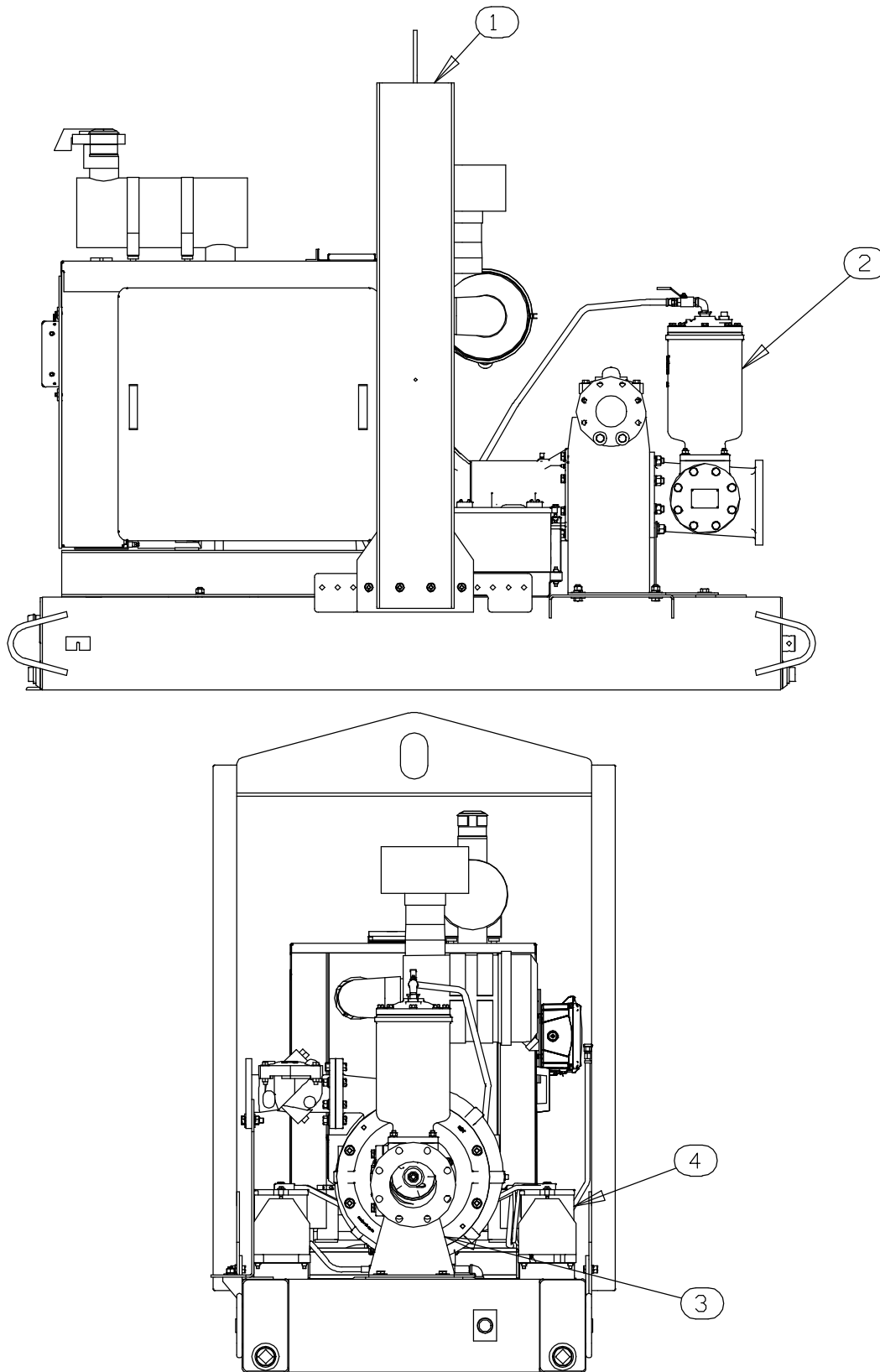

Figure 1. Pump Model PAH4D60-QSB4.5P

---

**Pump Model PAH4D60-QSB4.5P**
**PARTS LIST**

(From S/N 1658394 Up)

ITEM NO.	PART NAME	PART NUMBER	QTY
1	POWER UNIT	46143-148	1
2	PUMP END ASSEMBLY	46183-122	1
3	PUMP MOUNTING KIT	48157-061	1
4	BATTERY 12V	SEE OPTIONS	REF
NOT SHOWN:			
	G-R DECAL	GR-06	2
	PRIME AIRE PLUS DECAL	38812-098	2
	CAUTION DECAL	2613FJ	1
OPTIONAL:			
	BATTERY	29331-519	2

ILLUSTRATION

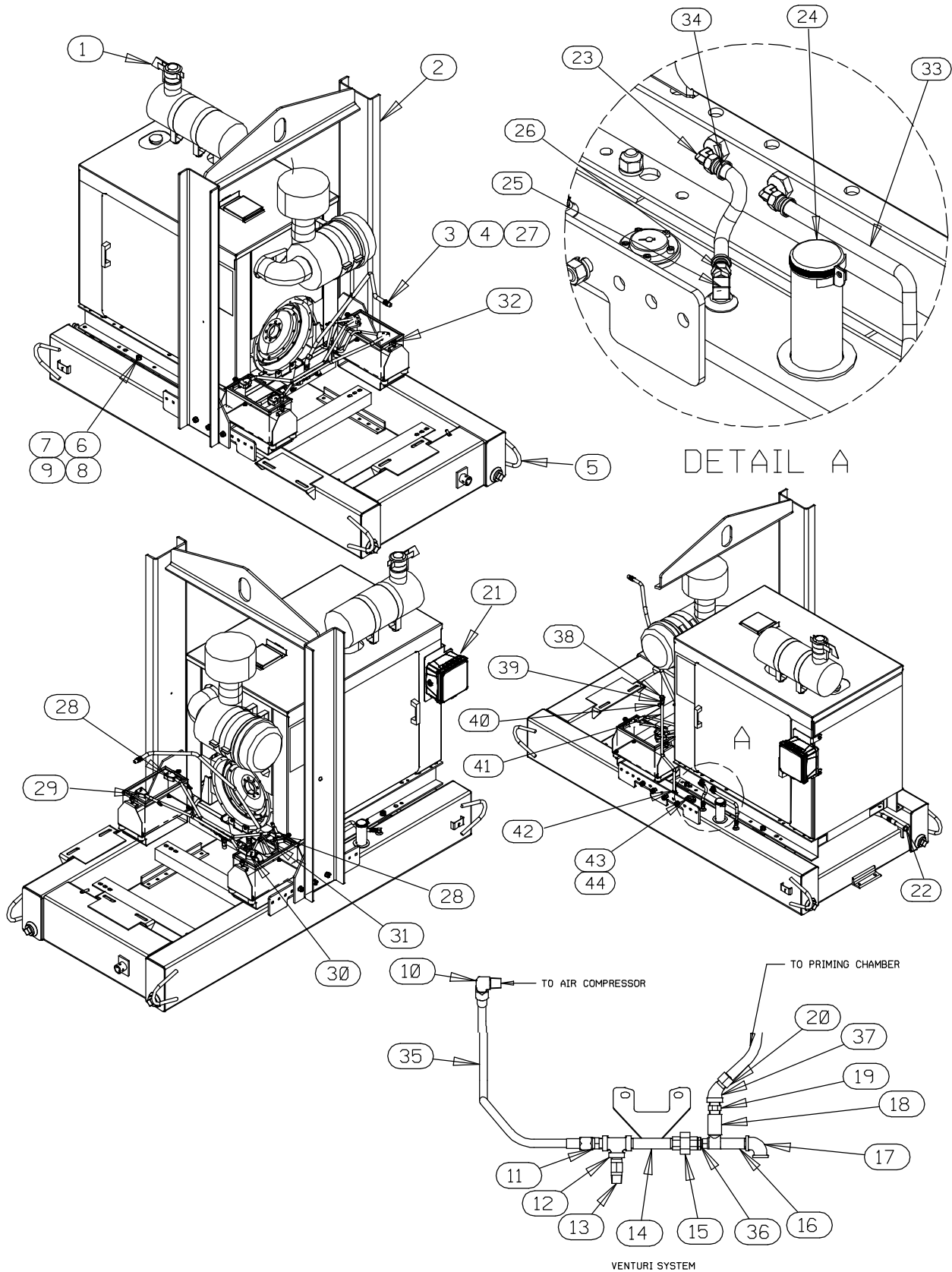

Figure 2. Power Unit Kit

## PARTS LIST

### Power Unit Kit

ITEM NO.	PART NAME	PART NUMBER	QTY	ITEM NO.	PART NAME	PART NUMBER	QTY
1	CUMMINS 4.5 ENGINE	29216-352	1	28	2/O POS CABLE ASS'Y	47311-223	2
2	LIFTING BAIL KIT	48274-804	1	29	2/O NEG CABLE ASS'Y	47311-224	1
3	HOSE BARB FTG	26523-047	1	30	2/O NEG CABLE ASS'Y	47311-225	1
4	CONNECTOR	S1598	1	31	#4 RED CABLE ASS'Y	47311-556	1
5	BASE / FUEL TANK ASSY	41553-045 24150	1	32	BATTERY BOX ASSY	42432-009	2
6	HEX NUT	D10 15991	4	33	HOSE ASSEMBLY	46341-815	1
7	HEX HEAD CAP SCREW	B1007 15991	4	34	HOSE ASSEMBLY	46341-788	1
8	LOCK WASHER	J10 15991	4	35	HOSE ASSY	46341-425	1
9	FLAT WASHER	21161-442	4	36	RED PIPE BUSHING	AP0806 15079	1
10	MALE ELBOW	26341-310	1	37	PIPE ELBOW	AGS08 11999	1
11	CONNECTOR	26351-065	1	38	AIR VENT	S1703	1
12	PIPE TEE	U08 11999	1	39	HOSE BARB FITTING	26523-447	1
13	PRESSURE RELIEF VALVE	26662-028	1	40	CABLE TIE	27111-218	1
14	VENTURI MTG BRACKET	41888-199 24150	1	41	3/8" ID X 36" LG HOSE	18513-302	1
15	PIPE UNION	AH08 11999	1	42	HOSE BARB FITTING	26523-389	1
16	VENTURI	26817-002	1	43	MECH FUEL GAUGE ASSY	29332-173	1
17	PIPE ELBOW	R08 11999	1	44	SOC HD MACH SCREW	BD#10-03S 15991	5
18	PIPE CPLG 1/2	AE08 15079	1	NOT SHOWN:			
19	1/2" CHECK VALVE	26641-092	1		ENGINE START UP TAG	38816-269	1
20	HOSE BARB FITTING	26523-446	1		WARNING DECAL	38816-203	4
21	CTRL PANEL INSTALL KIT	48122-560	1		INSTRUCTION DECAL	38818-144	1
22	OIL DRAIN ASSEMBLY	46342-057	1		WARNING DECAL	38816-132	2
23	MALE ELBOW	26351-131	2		FLOAT SWITCH KIT	48312-980	1
24	FUEL TANK CAP	29332-111	1		FUEL DECAL	38816-196	1
25	FUEL PICKUP	29332-145	2		WARNING DECAL	38817-101	2
26	CONNECTOR	S1447	2		WARNING DECAL	2613FE	1
27	1/2" ID X 60" LG HOSE	18513-113	1				

ILLUSTRATION

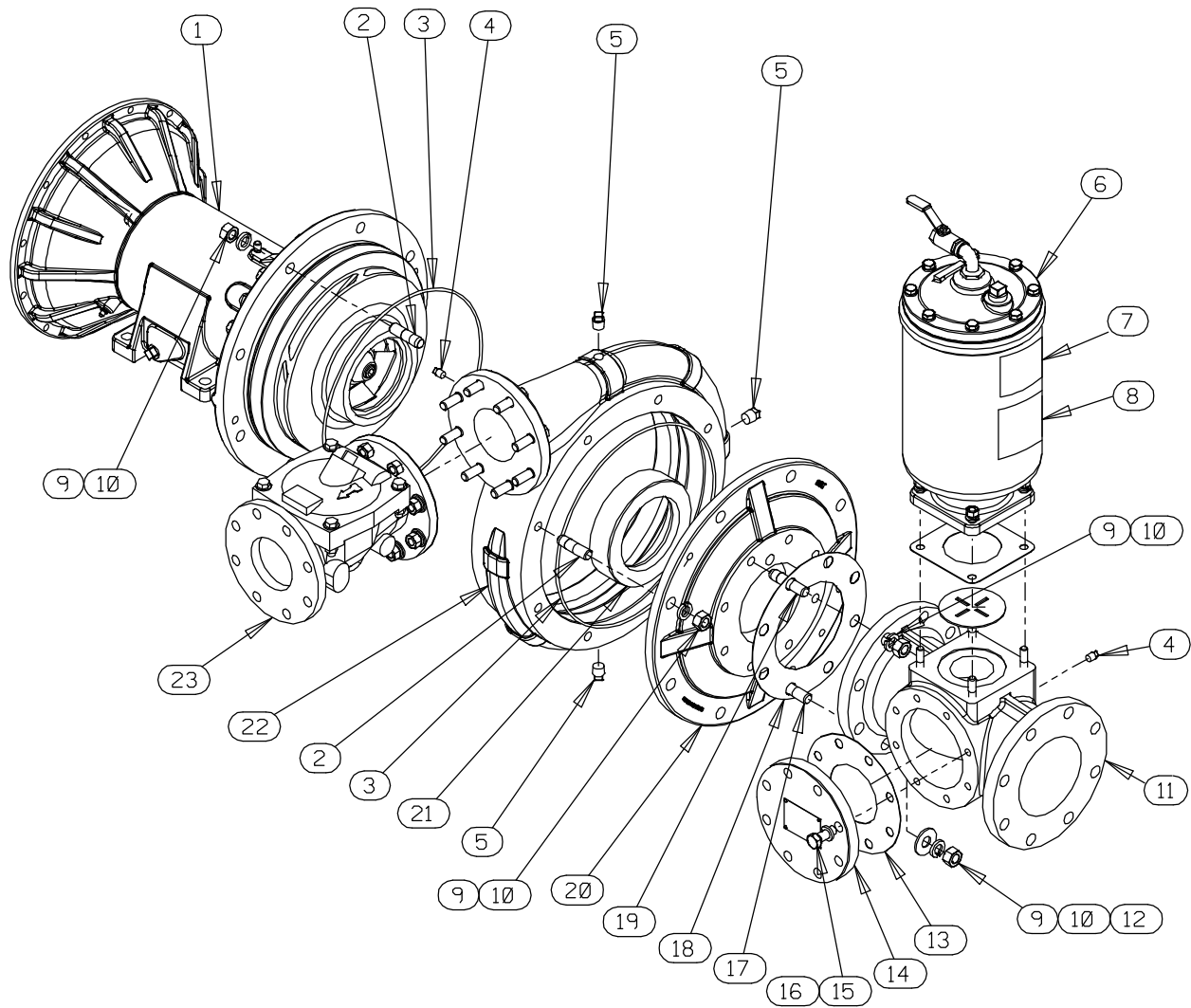

Figure 3. PUMP END ASSEMBLY

**PUMP END ASSEMBLY  
PARTS LIST**

ITEM NO.	PART NAME	PART NUMBER	QTY
1	REPAIR ROTATING ASSY	44163-696	1
☞ 2	STUD	C1211 15991	16
3	* O-RING	25152-384	2
☞ 4	PIPE PLUG	P04 15079	2
☞ 5	PIPE PLUG	P08 15079	3
6	PRIMING CHAMBER KIT	48275-005	1
7	G-R DECAL	GR-06	1
8	PRIME AIRE PLUS DECAL	38812-099	1
9	LOCK WASHER	J12 15991	24
10	HEX NUT	D12 15991	24
11	6" SUCTION SPOOL	38644-814 10000	1
12	FLAT WASHER	K12 15991	2
13	* GASKET	25113-034	1
14	4" BLIND FLANGE ASSEMBLY	42111-358	1
15	HEX HEAD CAP SCREW	B1007 15991	8
16	LOCK WASHER	J10 15991	8
17	STUD	C1214 15991	2
18	* GASKET	25113-036	1
19	STUD	C1213 15991	6
20	SUCTION HEAD	38246-615 11010	1
21	* WEAR RING	38691-369 11010	1
☞ 22	PUMP CASING	SEE NOTE BELOW	1
23	CHECK VALVE KIT 4"	48274-003	1
	-FLANGE GASKET	25113-034	1
	-CHECK VALVE	26642-124	1
	* --FLAPPER	26688-005	1
	* --COVER O-RING	25152-366	1
NOT SHOWN:			
	NAMEPLATE BLANK	38819-002 13000	1
	DRIVE SCREW	BM#04-03 17000	4
	SUCTION STICKER	6588AG	1
	DISCHARGE STICKER	6588BJ	1
	WARNING DECAL	2613FE	1
	INSTRUCTION TAG	38817-104	1
	DRIVE ASSEMBLY	44162-167	1
☞	INCLUDED W/REPAIR PUMP CASING ASSY	46474-909	1

\* INDICATES PARTS RECOMMENDED FOR STOCK

ILLUSTRATION

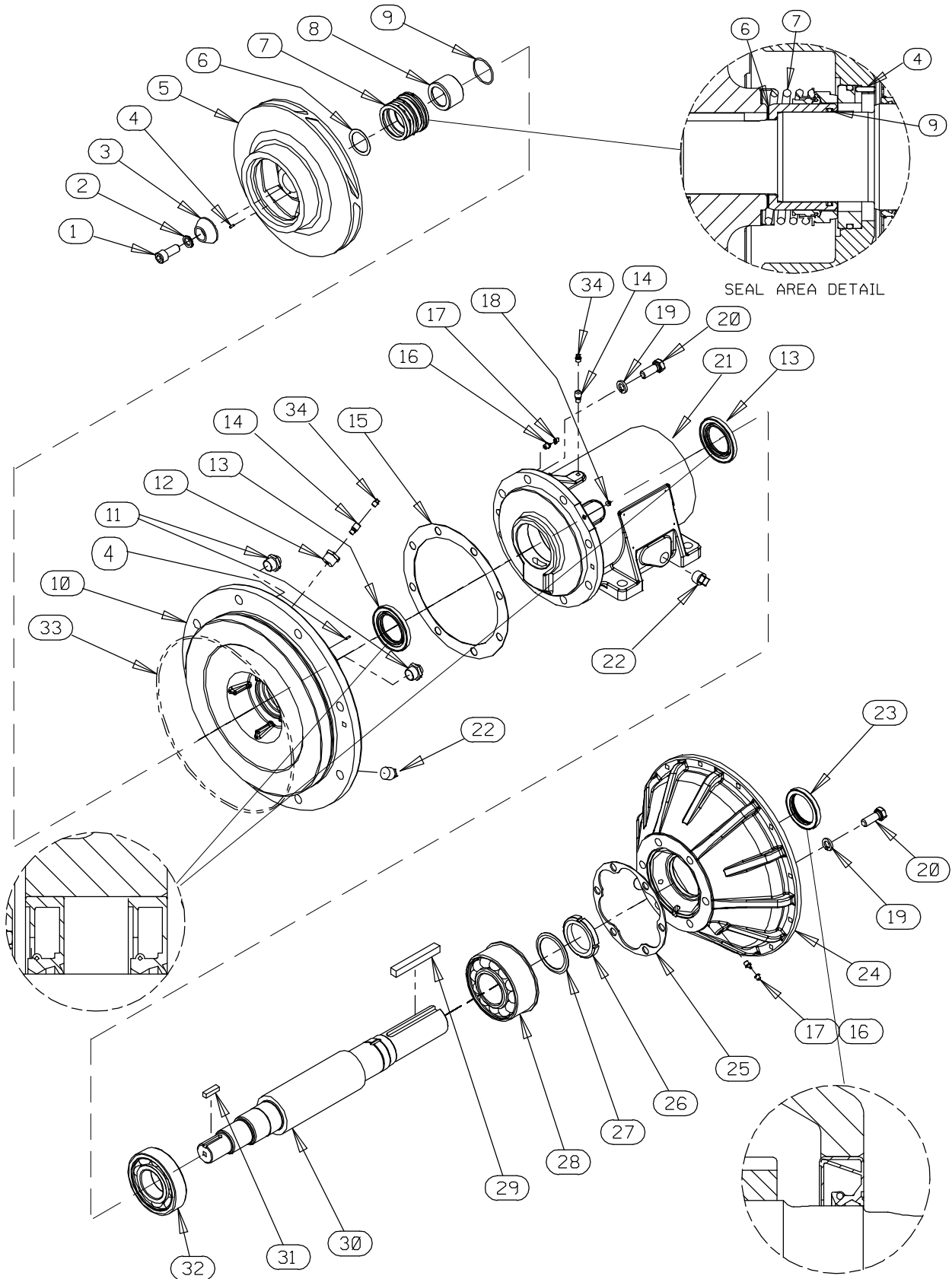

Figure 4. Repair Rotating Assembly

**PARTS LIST**  
**Repair Rotating Assembly**

ITEM NO.	PART NAME	PART NUMBER	QTY
1	SOCKET HEAD CAP SCREW	DM1006 15991	1
2	WASHER NORD-LOCK 5/8"	21177-221	1
3	IMPELLER WASHER	31177-007 17000	1
4	ROLL PIN	S2197	2
5	IMPELLER	38623-534 11010	1
6	* ADJ SHIM	8499 17000	1
7	* MECH SEAL 2-1/2"	25285-816	1
8	* SHAFT SLEEVE	31441-033 17000	1
9	* O-RING	25152-138	1
10	SEAL PLATE	38272-534 10000	1
11	SIGHT GAUGE	S1471	2
12	REDUCER PIPE BUSHING	AP1202 15079	1
13	* OIL SEAL	25227-772	2
14	AIR VENT	S1530	2
15	* GASKET	38683-665 19370	1
16	LUBE FITTING	S186	4
17	CAP PLUG	25141-151	4
18	SOC HD PIPE PLUG	PC02 15079	2
19	LOCK WASHER	J10 15991	14
20	HEX HEAD CAP SCREW	B1007 15991	14
21	PEDESTAL	38257-212 10000	1
22	PIPE PLUG	P12 15079	3
23	* OIL SEAL	25258-845	1
24	DRIVE FLANGE - SAE 3	38545-030 10000	1
25	* BEARING CAP GASKET	38683-664 19060	1
26	BEARING LOCKNUT	23962-015	1
27	LOCKING TAB COLLAR	23962-515	1
28	BEARING	23422-417	1
29	* KEY	N1020 15990	1
30	IMPELLER SHAFT	38512-543 1600X	1
31	* KEY	N0606 15990	1
32	* BALL BEARING	S1217	1
33	O-RING	25152-384	1
34	SHIPPING PLUG	11495C 15079	2
NOT SHOWN:			
	INSTRUCTION TAG	6588U	1
	LUBRICATION DECAL	38817-103	1

\* INDICATES PARTS RECOMMENDED FOR STOCK



ILLUSTRATION

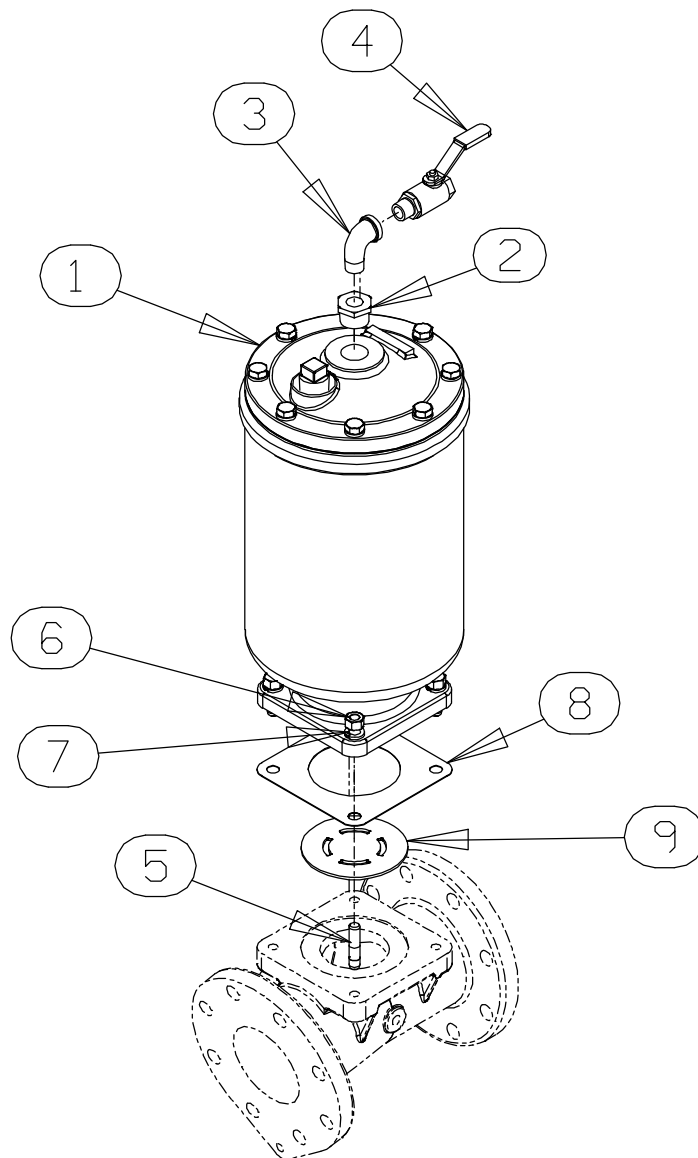

Figure 5. Priming Chamber Kit

PARTS LIST

ITEM NO.	PART NAME	PART NUMBER	QTY
1	PRIMING CHAMBER ASSY	46112-709	1
2	PIPE BUSHING	AP1608 15070	1
3	STREET ELBOW	RS08 11999	1
4	BALL VALVE	26631-052	1
5	STUD	C0809 15991	4
6	HEX NUT	D08 15991	4
7	LOCK WASHER	J08 15991	4
8	* GASKET	38687-053 19060	1
9	BAFFLE	31113-011 17000	1

\* INDICATES PARTS RECOMMENDED FOR STOCK

ILLUSTRATION

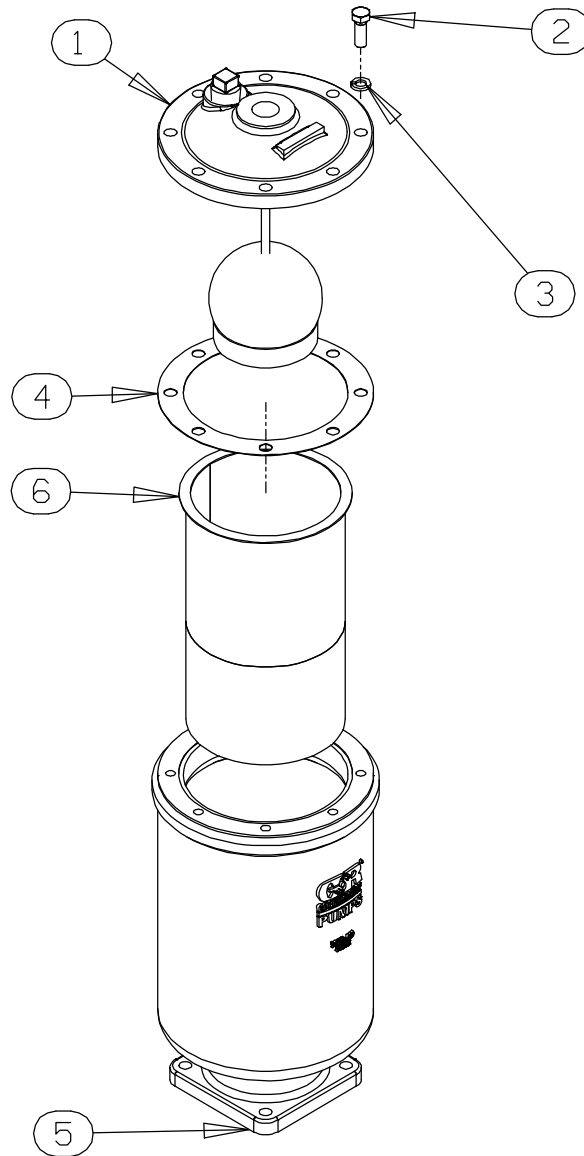

Figure 6. Priming Chamber Assembly

PARTS LIST

ITEM NO.	PART NAME	PART NUMBER	QTY
1	PRIMING VALVE	26664-007	1
	-ORIFICE BUTTON	26688-021	1
2	HEX HD CAPSCREW	B0806 15991	8
3	LOCKWASHER	J08 15991	8
4	* PRIMING VALVE GASKET	38683-657 19060	1
5	PRIMING CHAMBER	38343-020 10000	1
6	STRAINER ASSY	46641-222 17000	1

\* INDICATES PARTS RECOMMENDED FOR STOCK

ILLUSTRATION

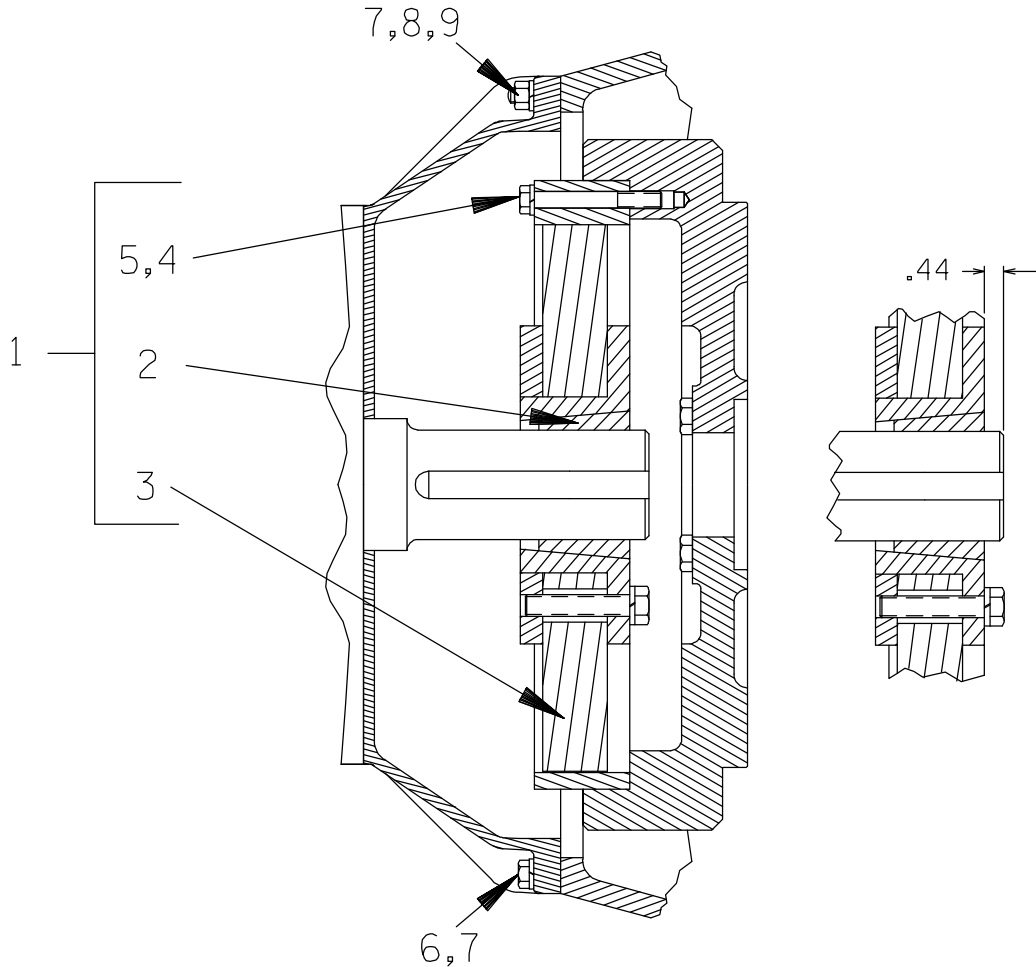













Figure 7. Drive Assembly

PARTS LIST

ITEM NO.	PART NAME	PART NUMBER	QTY
1	COUPLING KIT	48112-011	1
2	-BUSHING	24131-492	1
3	-COUPLING ASSEMBLY	24391-107	1
4	LOCKWASHER	21171-536	8
5	 HEX HEAD CAPSCREW	B0612 15991	8
5	 HEX HEAD CAPSCREW	22645-174	8
6	 HEX HEAD CAPSCREW	B0606 15991	10
6	 HEX HEAD CAPSCREW	22645-166	12
7	 LOCKWASHER	J06 15991	12
7	 LOCKWASHER	21171-511	12
8	 STUD	C0606 15991	2
8	 STUD	26821-879 15991	2
9	 HEX NUT	D06 15991	2
9	 HEX NUT	26821-932	2
	 USE FOR SAE APPLICATIONS		
	 USE FOR METRIC APPLICATIONS		

## PUMP AND SEAL DISASSEMBLY AND REASSEMBLY

Review all SAFETY information in Section A.

Follow the instructions on all tags, label and decals attached to the pump.

This pump requires little service due to its rugged, minimum-maintenance design. However, if it becomes necessary to inspect or replace the wearing parts, follow these instructions which are keyed to the illustrations (see Figures 1 through 7) and the corresponding Parts Lists. Instructions for the engine are covered separately in specific literature available from the manufacturer.

Some pump service functions may be performed without separating the pump end assembly from the engine. However, the priming chamber (6, Figure 3) and discharge check valve assembly (23, Figure 3) must be removed to service most pump components. The following instructions assume complete disassembly of the pump is required.

Before attempting to service the pump, shut down the engine and take precautions to ensure that it will remain inoperative. Close all valves in the suction and discharge lines and drain the pump casing by removing the lowermost pipe plug (5, Figure 3). Clean and reinstall the plug.



This manual will alert personnel to known procedures which require special attention, to those which could damage equipment, and to those which could be dangerous to personnel. However, this manual cannot possibly anticipate and provide detailed instructions and precautions for every situation that might occur during maintenance of the unit. Therefore, it is the responsibility of the owner/maintenance personnel to ensure that only safe, established maintenance procedures are used, and that any procedures not addressed in this manual are performed only after establishing that neither personal safety nor

pump integrity are compromised by such practices.



Before attempting to open or service the pump:

1. Familiarize yourself with this manual.
2. Shut down the engine and disconnect the positive battery cable to ensure that the pump will remain inoperative.
3. Allow the pump to completely cool if overheated.
4. Check the temperature and make sure it is cool before opening any covers, plates, gauges, or plugs.
5. Close the suction and discharge valves.
6. Vent the pump slowly and cautiously.
7. Drain the pump.



Death or serious personal injury and damage to the pump or components can occur if proper lifting procedures are not observed. Make certain that hoists, chains, slings or cables are in good working condition and of sufficient capacity and that they are positioned so that loads will be balanced and the pump or components will not be damaged when lifting. Suction and discharge hoses and piping must be removed from the pump before lifting. Lift the pump or component only as high as necessary and keep personnel away from suspended objects.



This pump is designed to handle material which could cause illness through di-

rect exposure or emitted fumes. Wear adequate protective clothing when working on the pump or piping.

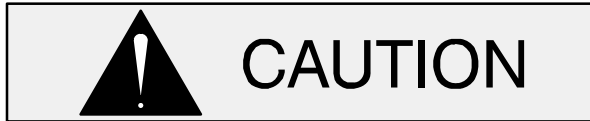

Use **only** replacement parts provided or approved by Gorman-Rupp. Use of non-authorized parts may result in damage to the equipment and/or injury to personnel and **will** invalidate the warranty.

### Priming Chamber Removal And Disassembly

#### (Figure 5)

Disconnect both the suction piping and the air discharge tubing from the priming chamber assembly (1). Support the priming chamber assembly using a sling and a suitable lifting device. Remove the hardware (6 and 7) and separate the priming chamber assembly, gasket (8) and baffle (9) from the spool (11, Figure 3).

#### (Figure 6)

Remove the hardware (2 and 3) securing the priming valve (1) to the priming chamber (5). Carefully lift the valve components from the priming chamber. Remove the gasket (4) and clean the mating surfaces.

If the priming valve float is stuck or the strainer (6) is clogged, it can usually be cleaned without further disassembly.

The only serviceable part of the priming valve is the orifice button (not shown). If liquid continues to bypass through the priming chamber after adjusting the orifice button (see **Priming Chamber Reassembly and Installation** for adjustment), the button may require replacement. To replace the orifice button, remove one of the “e-clips” from the pivot pin closest to the orifice button and remove the pivot pin. This will allow the linkage to be raised high enough to access the orifice button.

Remove the hex nut and lock washer securing the orifice button to the linkage bar and unscrew the orifice button from the linkage bar.

### Discharge Check Valve Removal and Disassembly

#### (Figure 3)

Remove the hardware (not shown) securing the discharge check valve bracket to the base.

Support the discharge check valve assembly (23) using a sling and a suitable lifting device. Remove the hardware (not shown) and separate the discharge check valve assembly and gasket (not shown) from the pump assembly (22).

The flapper and cover O-ring are the only serviceable parts of the check valve. If the flapper requires replacement, remove the hardware securing the cover. Separate the cover and O-ring and remove the flapper.

### Suction Head and Wear Ring Removal

#### (Figure 3)

The wear ring (21) is easily accessible and may be serviced by removing the suction head (20). Before attempting to service the pump, remove the lowermost pipe plug (5) from the pump casing (22) and drain the pump. Clean and reinstall the drain plug.

It is not necessary to remove the suction spool (11) from the suction head unless replacement of the spool, gasket (18) or suction head is required. To remove the suction spool, disengage the hardware (9 and 10) securing it to the pump casing.

Remove the hardware (9 and 10) and securing the suction head to the pump casing. Install two 5/8–11 UNC-2B capscrews (not supplied) in the tapped holes in the suction head and use the capscrews to press the suction head out of the pump casing. Remove the capscrews from the suction head.

Remove and discard the O-ring (3).

Inspect the wear ring and, if replacement is required, install two 3/4–10 UNC-2B capscrews (not supplied) in the tapped holes in the suction head and use the screws to press the wear ring out of the suction head. Remove the capscrews from the suction head.

## Pump Casing Removal

### (Figure 3)

Remove the uppermost pipe plug (5) from the pump casing and install a lifting eye in the hole. Be sure to screw the lifting eye tightly into the hole as far as it will go. Attach a sling and suitable lifting device to the lifting eye and support the pump casing.

Remove the hardware (9 and 10) and use the lifting device to pull the pump casing straight away from the rotating assembly (1).

Remove and discard the pump casing O-ring (3).

## Draining Oil From Seal Cavity

### (Figure 4)

If any further disassembly is to be performed on the pump, the seal oil cavity must be drained to prevent the oil in the seal cavity from escaping as the impeller is removed.

Position a **clean** container under the seal cavity drain plug (22). Remove the plug and drain the oil from the seal cavity into the container. For shorter drain time, remove the air vent (14). Clean and reinstall the drain plug and air vent. Inspect the oil for water, dirt or a cloudy condition which could indicate seal failure.

## Impeller Removal

### (Figure 4)

With the pump casing removed, use an impact wrench with a hex key to loosen the impeller capscrew (1). Remove the capscrew, impeller washers (2 and 3) and roll pin (4).

Use a suitable three-jawed puller to remove the impeller (5) and key (31) from the shaft (30). Use caution when removing the impeller; tension on the shaft seal spring will be released as the impeller is removed.

### NOTE

*An alternate method of removing the impeller is to insert a pair of wedges 180 ° apart between the impeller and seal plate (10). Tap the wedges evenly in an alternating pattern to “walk” the impeller off the shaft.*

Remove the impeller adjusting shims (6); tie and tag the shims, or measure and record their thickness for ease of reassembly.

Inspect the impeller and replace if cracked or badly worn.

## Seal Removal

### (Figures 4 and 8)

Remove the spring centering washer and seal spring. Slide the shaft sleeve (8) and rotating portion of the seal off the shaft as a unit.

Apply oil to the shaft sleeve and work it up under the rubber bellows. Slide the rotating portion of the seal off the shaft sleeve. Remove the shaft sleeve O-ring (9).

Use a pair of stiff wires with hooked ends to remove the stationary element from the seal plate bore.

An alternate method of removing the stationary seal components is to remove the hardware (19 and 20) and separate the seal plate and gasket (15) from the pedestal (21). Position the seal plate on a flat surface with the impeller side down. Use a wooden dowel or other suitable tool to press on the back side of the stationary element until the element and its O-ring can be removed.

If no further disassembly is required, refer to **Seal Installation**.

## Separating Pedestal and Drive Assembly From Engine

### (Figure 7)

Support the pedestal using a hoist and sling and remove the hardware (6, 7 and 9) securing the drive flange (24, Figure 4) to the engine bellhousing. Separate the assemblies by pulling the pedestal straight away from the engine.

As the assemblies separate, the flexible portion of the coupling assembly (3) will remain on the shaft. To remove the coupling from the shaft, unscrew the two allen head setscrews from the bushing (2). Screw one of the setscrews into the puller hole on the circumference of the bushing. As the coupling and bushing separate, remove the bushing, and slide the coupling off the shaft. Remove the shaft key (29, Figure 4).

It is not necessary to remove the outer ring of the coupling from the engine flywheel unless the coupling must be replaced. To remove the ring, disengage the hardware (4 and 5) securing it to the flywheel.

Move the pump end to a clean, well equipped shop area for further disassembly.

### Shaft and Bearing Removal and Disassembly

#### (Figure 4)

When the pump is properly operated and maintained, the pedestal (21) should not require disassembly. Disassemble the shaft and bearings **only** when there is evidence of wear or damage.



Shaft and bearing disassembly in the field is not recommended. These operations should be performed only in a properly equipped shop by qualified personnel.

#### NOTE

*There are no provisions for draining the lubricant from the pedestal. Place a drip pan under the pedestal before disassembly.*

If not removed with the seal assembly, remove the hardware (19 and 20) and separate the seal plate and gasket (15) from the pedestal (21).

Disengage the hardware (19 and 20) and remove the drive flange (24), gasket (25) and oil seal (23). Press the oil seal from the drive flange.

Place a block of wood against the impeller end of the shaft (30) and tap the shaft and assembled bearings (28 and 32) from the pedestal.

Press the oil seals (13) from the pedestal.

After removing the shaft and bearings, clean and inspect the bearings **in place** as follows.



To prevent damage during removal from

the shaft, it is recommended that bearings be cleaned and inspected **in place**. It is **strongly** recommended that the bearings be replaced **any** time the shaft and bearings are removed.

Clean the pedestal, shaft and all component parts (except the bearings) with a soft cloth soaked in cleaning solvent. Inspect the parts for wear or damage and replace as necessary.



**Most cleaning solvents are toxic and flammable. Use them only in a well ventilated area free from excessive heat, sparks, and flame. Read and follow all precautions printed on solvent containers.**

Clean the bearings thoroughly in **fresh** cleaning solvent. Dry the bearings with filtered compressed air and coat with light oil.



Bearings must be kept free of all dirt and foreign material. Failure to do so will greatly shorten bearing life. **Do not** spin dry bearings. This may scratch the balls or races and cause premature bearing failure.

Rotate the bearings by hand to check for roughness or binding and inspect the bearing rollers and balls. If rotation is rough or the rollers or bearing balls are discolored, replace the bearings.

The bearing tolerances provide a tight press fit onto the shaft and a snug slip fit into the pedestal. Replace the bearings, shaft, or pedestal if the proper bearing fit is not achieved.

If bearing replacement is required, straighten the tab on the bearing lock washer (27). Use a spanner wrench to remove the bearing lock nut (26). Remove the bearing lock washer.

Use a bearing puller to remove the inboard and outboard bearings from the shaft.

## Shaft and Bearing Reassembly and Installation

### (Figure 4)

Inspect the shaft (30) for distortion, nicks or scratches, or for thread damage on the impeller end. Dress small nicks and burrs with a fine file or emery cloth. Replace the shaft if defective.

Clean and inspect the bearings as indicated in **Shaft And Bearing Removal And Disassembly**.



To prevent damage during removal from the shaft, it is recommended that bearings be cleaned and inspected **in place**. It is **strongly** recommended that the bearings be replaced **any** time the shaft and bearings are removed.

The bearings may be heated to ease installation. An induction heater, hot oil bath, electric oven, or hot plate may be used to heat the bearings. Bearings should **never** be heated with a direct flame or directly on a hot plate.

### NOTE

*If a hot oil bath is used to heat the bearings, both the oil and the container must be **absolutely** clean. If the oil has been previously used, it must be **thoroughly** filtered.*

### NOTE

*Position the outboard bearing (28) on the shaft with the retaining ring on the bearing O.D. **toward the drive end of the shaft**. The inboard bearing (32) is equipped with a flange ring that is shipped loose with the bearing. Install the flange ring on the shaft prior to heating and installing the bearings.*

Heat the bearings to a uniform temperature **no higher than** 250°F (120°C), and slide the bearings onto the shaft, one at a time, until they are fully seated against the shaft shoulders. This should be done quickly, in one continuous motion, to prevent the bearings from cooling and sticking on the shaft.

After the bearings have been installed and allowed to cool, check to ensure that they have not moved

during cooling. If movement has occurred, use a suitably sized sleeve and a press to reposition the bearings against the shaft shoulders.

If heating the bearings is not practical, use a suitably sized sleeve and an arbor (or hydraulic) press to install the bearings on the shaft.

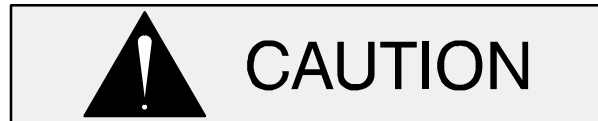

When installing the bearings onto the shaft, **never** press or hit against the outer race, balls, rollers or cage. Press **only** on the inner race.

After installation, pack the bearings by hand with EP2 lithium base grease until fully lubricated.

Slide the shaft and assembled bearings into the pedestal until the inboard bearing is fully seated against the bearing retaining ring.

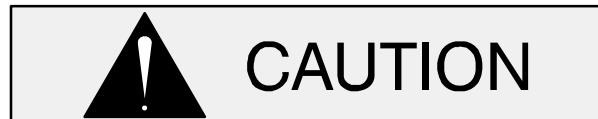

It is recommended that a new bearing lock washer (27) be installed any time the shaft and bearings are disassembled. Re-use of an old lock washer may create a pre-load condition on the bearing, resulting in premature bearing failure.

Install the bearing lockwasher (27) and screw the bearing locknut (26) onto the shaft until tight. Torque the bearing lock nut to 150 ft. lbs. (20,8 m. kg.). After torquing, locate the tab on the lock washer that aligns with a slot in the lock nut and bend the tab over into the slot.

Apply a light coating of oil to the lip of the inboard oil seal (13) and press it into the pedestal bore with the lip positioned as shown in Figure 4. Press the oil seal into the pedestal until the face is **just flush** with the machined surface on the pedestal.

It is recommended that a sleeve be positioned against the inboard oil seal to prevent the lip of the oil seal from rolling as the shaft and bearings are installed in the pedestal. The O.D. of the sleeve should be just smaller than the pedestal bore, while the I.D. of the sleeve should be just larger than the O.D. of the oil seal area of the shaft.



With the oil seal sleeve in place, lubricate the oil seal area of the shaft and slide the shaft and assembled bearings into the pedestal until the retaining ring on the outboard bearing seats against the pedestal. Remove the oil seal sleeve.



When installing the shaft and bearings into the bearing bore, push against the outer race. **Never** hit the balls, rollers or cages.

Apply a light coating of oil to the lip of the outboard oil seal (13) and press it into the pedestal with the lip positioned as shown in Figure 4. The face of the oil seal should be **just flush** with the outer face of the pedestal.

Apply a light coating of oil to the lip of the oil seal (23) and press it into the drive flange (24) with the lip positioned as shown in Figure 4. The oil seal should be centered in the flange bore.

Install the gasket (25) and slide the assembled drive flange and oil seal over the impeller shaft. Use caution not to cut or roll the lip of the oil seal (23) on the shaft keyway. Secure the drive flange to the pedestal with the hardware (19 and 20). Torque the capscrews (20) initially to 80 ft. lbs. (11 m. kg.) in a criss-cross pattern, then torque the capscrews again to 110 ft. Lbs (15,2 m. kg.) in a criss-cross pattern, going around the bolt circle 1-1/2 times.

Lubricate the bearings as indicated in **LUBRICATION** at the end of this section.

### Securing Pedestal And Drive Assembly To Engine

#### (Figure 7)

Install the shaft key (29, Figure 4) in the shaft keyway. Position the flexible portion of the coupling assembly (3) on the shaft as shown in Figure 7.

#### NOTE

*The flexible portion of the coupling must be properly positioned on the shaft. The heads of the capscrews in the center of the coupling **must be positioned away from the pump.***

Align the keyway in the bushing (2) with the shaft key, and slide it onto the shaft until the face of the bushing is just flush with the end of the shaft. Rotate the flexible portion of the coupling until the tapped holes for the two setscrews align with those in the bushing, and install the setscrews.



Make certain that the flexible portion of the coupling is mounted as shown in Figure 7. **This is critical.** If the coupling is not properly positioned on the shaft, the coupling parts may not fully engage, or a pre-load condition can cause premature bearing failure.

**The end of the shaft must be extend 0.44 inch (11 mm) from the face of the bushing.** This will allow the two portions of the coupling to fully engage when the engine bracket is secured to the engine bellhousing without pre-loading the bearings.

With the flexible portion of the coupling and the bushing properly positioned on the shaft, tighten the two setscrews in an alternating sequence until the bushing and coupling are fully secured. Torque the setscrews to 35.8 ft. lbs. (430 in. lbs. or 4,9 m. kg.).

If the complete coupling assembly is being replaced, apply 'Loctite Retaining Compound No. 242' or equivalent to the threads of the hardware (4 and 5) and secure the outer ring of the coupling to the engine flywheel by torquing the hardware to 45 ft. lbs. (6,2 m. kg.).

Using a suitable lifting device, position the assembled drive and rotating assembly so the flexible portion of the coupling seats inside the outer ring attached to the engine flywheel.

#### NOTE

*To ease installation, **lightly** lubricate the rubber portion of the coupling with a **non-petroleum based lubricant** such as vegetable oil or glycerin, or a silicon-based lubricant such as "WD40" or equivalent. **Do not** use petroleum-based lubricants, or any other substance which may soften or otherwise damage the rubber.*

Secure the drive flange (24, Figure 4) to the engine bellhousing with the previously removed hardware (6, 7 and 9).

**Seal Reassembly and Installation**

(Figures 4 and 8)



**Most cleaning solvents are toxic and flammable. Use them only in a well ventilated area free from excessive heat, sparks, and flame. Read and follow all precautions printed on solvent containers.**

Clean the seal cavity and shaft with a cloth soaked in fresh cleaning solvent. Inspect the stationary

seat bore in the seal plate for dirt, nicks and burrs, and remove any that exist. The stationary seat bore **must** be completely clean before installing the seal.

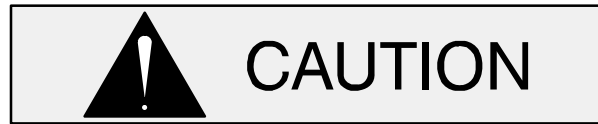

A new seal assembly should be installed **any time** the old seal is removed from the pump. Wear patterns on the finished faces cannot be realigned during reassembly. Reusing an old seal could result in premature failure.

To ease installation of the seal, lubricate the shaft sleeve O-ring and the stationary element O-ring with a very **small** amount of light lubricating oil. See Figure 8 for seal part identification.

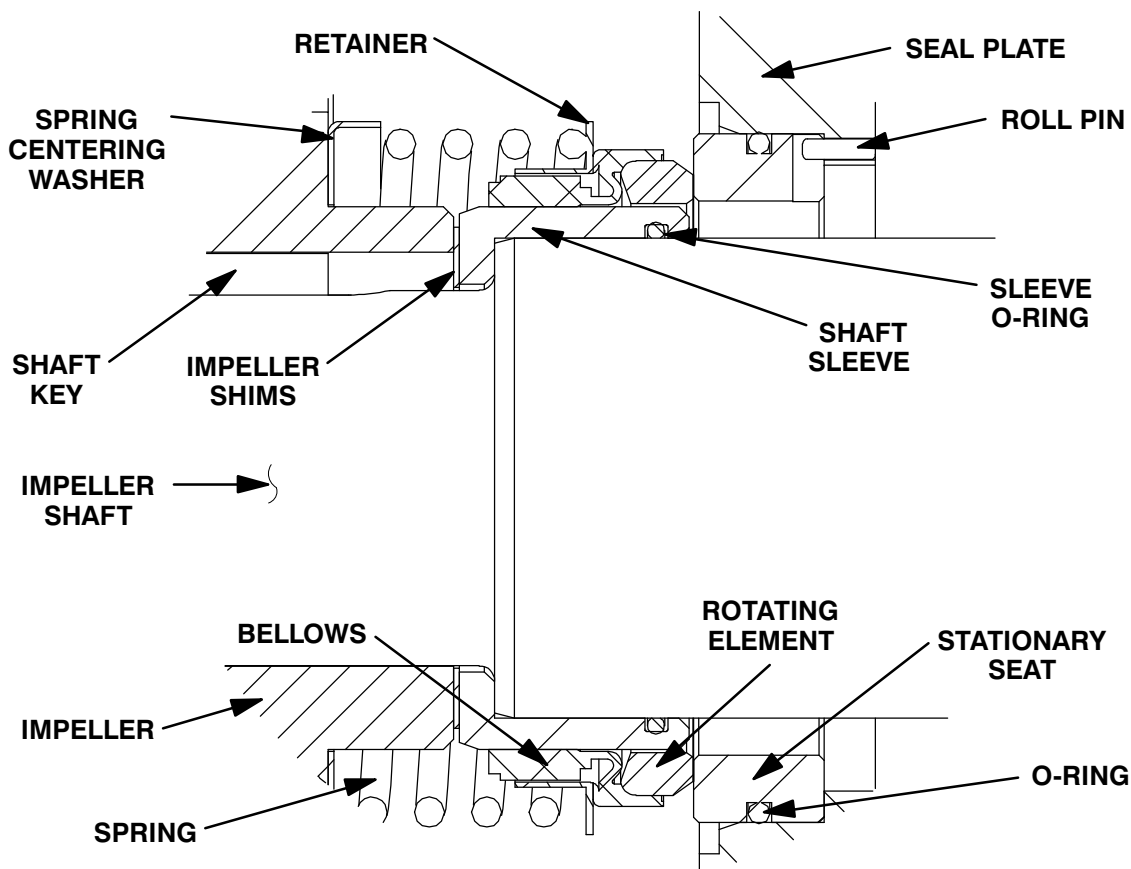

**Figure 8. Seal Assembly**



This seal is not designed for operation at

temperatures above 160°F (71°C). Do not use at higher operating temperatures.

If the seal plate was removed, install the seal plate gasket (15). Position the seal plate over the shaft

and secure it to the pedestal with the hardware (19 and 20). If a new seal plate is being installed, position the roll pin (4) in the hole in the seal plate bore and tap it into place with a hammer until fully seated.

Align the notch in the stationary seal seat with the roll pin (4) and press the stationary seat and its O-ring into the seal plate until fully seated in the seal plate bore. A push tube cut from a length of plastic pipe would aid this process. The I.D. of the tube should be slightly larger than the O.D. of the shaft sleeve (8).

Install the shaft sleeve O-ring (9) in the groove in the I.D. of the sleeve. Lubricate the O-ring and the O.D. of the shaft sleeve with "P-80<sup>®</sup> Emulsion" or water. **Do not** use oil or any substitute lubricant other than water.

Slide the rotating subassembly (consisting of the rotating element, retainer and bellows) onto the sleeve until the rotating element is **just flush** with the chamfered end of the sleeve. Slide the shaft sleeve and rotating subassembly onto the shaft until the seal faces contact and the shaft sleeve seats against the shoulder on the impeller shaft. Install the seal spring and spring centering washer.

Lubricate the seal assembly as indicated in **LUBRICATION**, after the impeller has been installed.

### Impeller Installation And Adjustment

#### (Figure 4)

Inspect the impeller (5) and replace it if cracked or badly worn.

Install the same thickness of adjusting shims (6) as previously installed. Install the impeller key (31) in the shaft keyway. Align the keyway in the impeller with the shaft key and press the impeller onto the shaft until fully seated.

A clearance of .025 to .040 inch (0,64 to 1,02 mm) between the impeller and the seal plate is necessary for maximum pump efficiency. Measure this clearance and add or remove impeller adjusting shims as required.

Apply 'Loctite Retaining Compound No. 242' or equivalent to the threads of the impeller capscrew

(1). Install the roll pin (4) in the hole in the impeller. Position the impeller washers over the end of the impeller shaft so the hole in the washer aligns with the roll pin. Use a strap wrench to block impeller rotation and torque the impeller capscrew to 300 ft. lbs. (41,5 m. kg.).

### Pump Casing Installation

#### (Figure 3)

Lubricate the O-ring (3) with light grease and install it in the groove in the O.D. of the seal plate. Install a lifting eye in the uppermost hole in the pump casing (22) for the pipe plug (5). Be sure to screw the lifting eye tightly into the hole as far as it will go. Attach a sling and suitable lifting device to the lifting eye and use the lifting device to position the pump casing over the rotating assembly. Install the hardware (9 and 10) on the studs (2) and use the hardware to fully seat the pump casing against the seal plate.

If the suction spool (11) was removed, install a new gasket (18) and secure the spool to the pump casing with the previously removed hardware (9 and 10).

### Suction Head and Wear Ring Installation

#### (Figure 3)

If the wear ring (21) was removed, position the replacement wear ring in the suction head (20) and use an arbor (or hydraulic) press to press it into the suction head until fully seated.

Install the O-ring (3) in the groove in the O.D. of the suction head and lubricate it with light grease. Position the suction head over the studs (17) and secure with the hardware (9 and 10).

### Discharge Check Valve Reassembly And Installation

#### (Figure 3)

If the discharge check valve (23) was disassembled to replace the flapper or cover O-ring, position the flapper in the valve body and check to ensure free movement.

Install the valve cover O-ring and secure the cover to the body with the previously removed hardware.

Apply a small amount of light grease to the discharge flange gasket to hold it in place and posi-

tion it against the pump casing flange. Support the discharge check valve assembly using a sling and a suitable lifting device. Using the previously removed hardware, secure the discharge check valve assembly and flange gasket to the pump assembly (22). Secure the discharge check valve to its support bracket using the previously removed hardware.

### Priming Chamber Assembly And Installation

#### (Figure 6)

Clean and inspect the components of the priming valve (1). Inspect the linkage and ensure the orifice button (not shown) squarely engages the valve seat. Replace the orifice button if required (see **Priming Chamber Removal and Disassembly** for orifice button removal).

If the orifice button was removed, screw the new orifice button into the linkage bar until fully seated. Align the hole in the linkage bar with the holes in the bracket and reinstall the pivot pin. Secure the pivot pin with the previously removed “e-clip”.

Adjust the orifice button seating as necessary by screwing the orifice button into or out of the linkage bar. Proper adjustment is achieved when the orifice button fully seats against the orifice before the linkage bar on the float bottoms against the threads on the orifice button. When adjustment is complete, install and tighten the lock washer and hex nut securing the orifice button.

Install the strainer (6) and priming valve gasket (4).

Lower the float into the priming chamber (5) and secure the priming valve with the previously removed hardware (2 and 3).

#### (Figure 5)

Install the baffle and gasket (8 and 9) and use a sling and suitable lifting device to position the priming chamber assembly on the pump suction spool (11, Figure 3). Secure the priming chamber assembly with the hardware (6 and 7).

Reconnect both the suction piping and the air discharge tubing to the priming chamber assembly.

## LUBRICATION

### Seal Assembly

#### (Figure 4)

Before starting the pump, remove the air vent and bushing (12 and 14) and fill the seal cavity with approximately 170 ounces (5 liters) of SAE No. 30 non-detergent oil to the center of the sight gauge(s) (11). Clean and reinstall the air vent and bushing. Check the oil level regularly and maintain it at the middle of the sight gauge.

### Bearings

#### (Figure 4)

The pedestal was fully lubricated when shipped from the factory. The grease fittings (16) are protected from contamination by the cap plugs (17). Remove the cap plugs and clean the grease fittings **thoroughly** before adding grease. After lubricating the bearings, clean the fittings and reinstall the cap plugs.

Under normal conditions, re-lubricate the bearings after every 1500 hours of use by adding 1 oz. (28 g.) of lithium EP2 grease to the impeller end bearing and 2 oz. (56 g.) of grease to the drive end bearing. **Do not** over-lubricate. Over-lubrication can cause the bearings to over-heat, resulting in premature bearing failure.

When lubricating a **new** bearing pedestal, pack the bearings by hand with lithium EP2 grease until fully lubricated prior to installing the shaft and bearings into the pedestal. After installing the shaft and bearings into the pedestal, lubricate the bearings as follows:

Impeller End Bearing: 4 oz. (113 g) each fitting  
Drive End Bearing: 8 oz. (226 g) each fitting

### Engine

Consult the literature supplied with the engine, or contact your local engine representative.

**For Warranty Information, Please Visit  
[www.grpumps.com/warranty](http://www.grpumps.com/warranty)  
or call:  
U.S.: 419-755-1280  
Canada: 519-631-2870  
International: +1-419-755-1352**

**GORMAN-RUPP PUMPS**