



Self Priming Centrifugal Pump

Model 83A2-GX270

Size 3" x 3"



Total Head		Capacity Of Pump In U.S. Gallons Per Minute (GPM) At Continuous Performance				
P.S.I.	Feet					
54.2	125	37	37	37	37	37
52.0	120	55	55	55	55	55
43.4	100	130	130	130	130	130
34.7	80	163	195	195	195	195
26.0	60	174	235	249	246	246
17.3	40	177	250	295	301	301
8.7	20	179	255	303	337	350
Suction Lift		25'	20'	15'	10'	5'



PUMP SPECIFICATIONS

- Size:** 3" x 3" (76 mm x 76 mm) NPT - Female.
- Casing:** Gray Iron 30.
Maximum Operating Pressure 87 psi (600 kPa).*
- Semi-Open Type, Four Vane Impeller:** Gray Iron 30.
Handles 3/4" (19,1 mm) Diameter, Spherical Solids.
- Replaceable Wear Plate:** Carbon Steel ASTM A36.
- Intermediate Bracket:** Gray Iron 30.
- Seal:** Double, Grease-Lubricated w/Spring-Loaded Grease Cup. Sintered Bronze Stationary Seal Seats. Steel Rotating Faces. Neoprene Packing Rings.
Maximum Temperature of Liquid Pumped, 110°F (43°C). Maximum Suction Pressure 10 psi (69 kPa).*
- Seal Liner:** Copper Alloy C26000.
- Flap Valve:** Buna-N w/Nylon Reinforcement and Gray Iron 30.
- Discharge Service Tee:** Gray Iron 30.
- Flange:** Gray Iron 25.
- Gaskets:** Vegetable Fiber.
- Hardware:** Standard Plated Steel.
- Standard Equipment:** Roll Cage w/Rubber Feet. Strainer.
- Optional Equipment:** Wheel Kit w/Semi-Pneumatic Tires.

*Consult Factory for Applications Exceeding Maximum Pressure and/or Temperature Indicated.



ENGINE SPECIFICATIONS:

- Model:** Honda GX270
- Type:** Single Cylinder, Four Cycle, Air Cooled, Overhead Valve, Gasoline Engine.
- Displacement:** 16.5 Cu. In. (270 cc).
- Carburetor:** Horizontal Type.
- Cylinder:** Aluminum Alloy w/Cast Iron Liner.
- Lubrication:** Splash System.
- Air Cleaner:** Dry Type, Dual Element.
- Fuel Tank:** 1.4 U.S. Gallons (5,3 Liters)
- Full Load Operating Time:** Unavailable.**
- Ignition System:** Transistorized Magneto.
- Standard Equipment:** Muffler w/Guard.
Manual Throttle Control with Top Speed Limit.
Manual Choke. "Oil Alert™" Low Oil Shut Down.

** Fuel Consumption Data Not Available From Engine Manufacturer.



GORMAN-RUPP PUMPS

www.grpumps.com

Specifications Subject to Change Without Notice

Printed in U.S.A.

Specification Data

SECTION 40, PAGE 875

APPROXIMATE DIMENSIONS and WEIGHTS

ROLL CAGE

NET WEIGHT: 180 LBS. [82 KG.]
SHIPPING WEIGHT: 185 LBS. [84 KG.]
EXPORT CRATE SIZE: 7.0 CU. FT. [.20 CU. M.]

2-WHEEL

195 LBS. [89 KG.]
201 LBS. [91 KG.]
10.0 CU. FT. [.28 CU. M.]

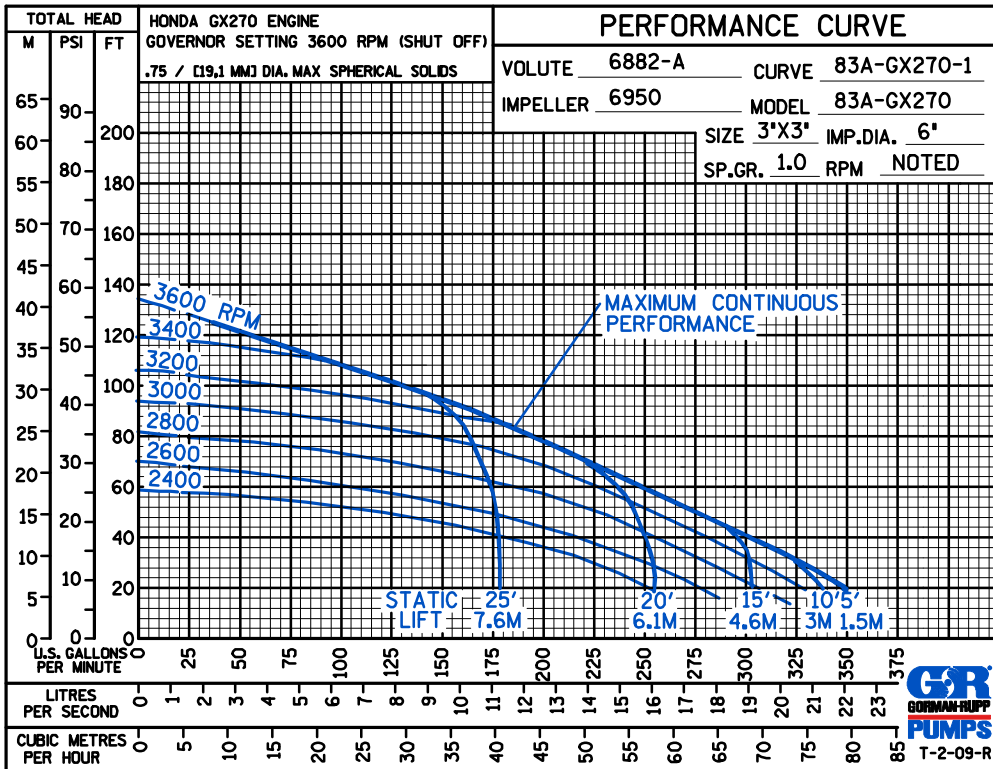
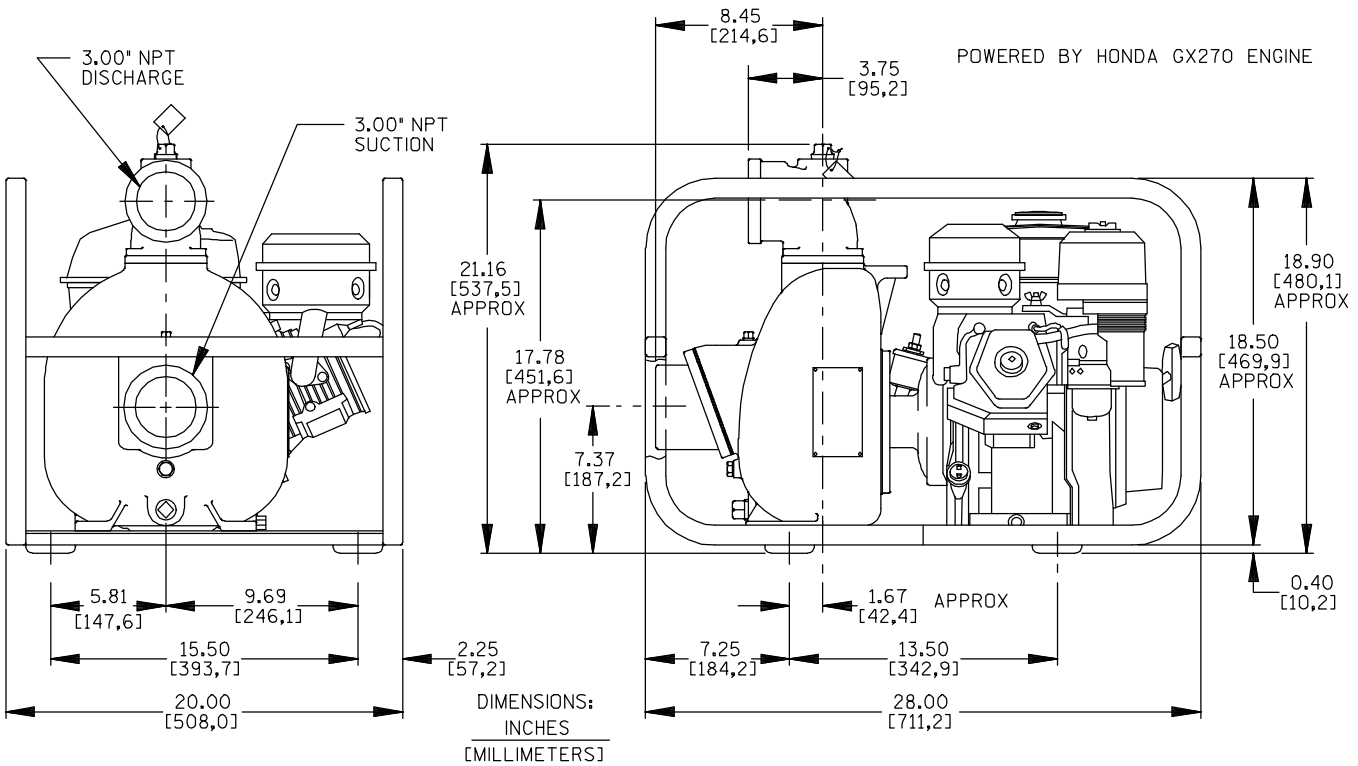

GORMAN-RUPP PUMPS

www.grpumps.com

Specifications Subject to Change Without Notice

Printed in U.S.A.