

# Priming Assisted Centrifugal Pump w/Autostart



Model PA12A60-B-QSB4.5P

Size 12" x 12"



Total Head		Capacity of Pump in U.S. Gallons per Minute (GPM) at Continuous Performance				
P.S.I.	Feet	1100	1100	1100	1100	1100
45.1	104	1100	1100	1100	1100	1100
43.4	100	2000	2300	2300	2300	2300
39.0	90	2700	3620	3750	3750	3750
34.7	80	3010	4120	4650	4700	4700
30.4	70	3090	4250	5060	5430	5430
26.0	60	3150	4300	5100	5710	5925
22.7	50	3200	4350	5150	5850	6040
17.3	40	3290	4400	5200	5900	6100
13.0	30	3350	4450	5250	5910	6190
8.7	20	3400	4500	5300	5920	6300
<b>Suction Lift</b>		<b>25'</b>	<b>20'</b>	<b>15'</b>	<b>10'</b>	<b>5'</b>



**PUMP SPECIFICATIONS**

**Size:** 12" x 12" (305 mm x 305 mm) Flanged.  
**Casing:** Gray Iron 30. Maximum Operating Pressure 71 psi (490 kPa).\*  
**Enclosed Type, Three Vane Impeller:** Ductile Iron 60-40-18.  
 Handles 3" (76.2 mm) Diameter Spherical Solids.  
**Impeller Shaft:** Stainless Steel 17-4 PH.  
**Replaceable Wear Rings:** Impeller - Ductile Iron 80-60-03.  
**Suction Head -** Copper Alloy C93200.  
**Seal Plate:** Gray Iron 30.  
**Bearing Housing:** Gray Iron 30.  
**Seal:** Mechanical, Oil-Lubricated, Double Floating, Self-Aligning. Silicon Carbide Rotating and Stationary Faces. Stainless Steel 316 Stationary Seat. Buna-N and Fluorocarbon Elastomers (DuPont Viton® or Equivalent). Stainless Steel 18-8 Cage and Spring.  
 Maximum Temperature of Liquid Pumped 160°F (71°C).\*  
**Shaft Sleeve:** Stainless Steel 304.  
**Priming Chamber:** Gray Iron 30 Housing w/Stainless Steel Float and Linkage.  
**Discharge Check Valve:** Ductile Iron Housing w/Welded Nickel Seat and Buna-N Flapper.  
**Radial Bearing:** Single Row Roller.  
**Thrust Bearings:** Two Open Single Row Ball.  
**Bearing and Seal Cavity Lubrication:** SAE 30 Non-Detergent Oil.  
**Flanges:** Gray Iron 30.  
**Gaskets:** Vegetable Fiber, Buna-N, Resistant Synthetic Rubber and Cork.  
**O-Rings:** Buna-N and Neoprene.  
**Hardware:** Standard Plated Steel.  
**Bearing and Seal Cavity Oil Level Sight Gauges.**  
*\*Consult Factory for Applications Exceeding Maximum Pressure and/or Temperature Indicated.*  
**Standard Equipment:** Gear Driven Air Compressor. 1.66:1 Gear Reducer. Hoisting Bail. Combination Skid Base w/Fuel Tank. Strainer. [Single Ball Type Float Switch.](#) \*\*  
**Optional Equipment:** Batteries (2 Req'd). Suction Vacuum and Discharge Pressure Gauge Kit. High Speed (55 MPH/89 KM/H) Tandem Axle Pneumatic-Tired Wheel Kit w/wo DOT-Approved Lights and Electric Brakes. [Full Feature Control Panel](#) For Use w/Submersible Transducer Liquid Level Sensor (50 Ft. [15 M] Cable Standard, Alternate Lengths Available).  
**\*\*50 Ft. (15 m) Standard Length; Dual Switches and Alternate Cable Lengths Available From the Factory.**

**WARNING!**  
 Do not use in explosive atmosphere or for pumping volatile flammable liquids.

**ENGINE SPECIFICATIONS**

**Model:** Cummins QSB4.5.  
**EPA Tier:** Tier 3.  
**Type:** Four Cylinder, Four Cycle, Turbocharged, Charge Air Cooled, Liquid Cooled Diesel Engine.  
**Displacement:** 272 Cu. In. (4.5 liters).  
**Governor:** Electronic.  
**Lubrication:** Forced Circulation.  
**Air Cleaner:** Dry Type.  
**Oil Reservoir:** 13.7 U.S. Qts. (13 liters) Dry; 11.6 U.S. Qts. (10 liters) Refill.  
**Fuel Tank:** 171 U.S. Gals. (684 Liters).  
**Full Load Operating Time:** 22.3 Hrs.  
**Starter:** 12V Electric.  
**Standard Features:** Engine Enclosure.  
**Optional Features:** Electronic Fuel Level Sensor..  
**Engine Control Features:** Padlockable Box with Throttle Control, Tachometer, Coolant Temperature, Oil Pressure, Voltage and Overstart Indicators/Shutdowns. Manual/Stop/Auto Keyswitch. Audible Startup Warning Delay. Fuel Level Display/Alarm/Shutdown (For Use With Optional Fuel Level Sensor).

**CUMMINS PUBLISHED PERFORMANCE:**  
 Maximum Gross Continuous BHP  
 130 (97 kW) @ 2200 RPM



GORMAN-RUPP PUMPS

www.grpumps.com

Specifications Subject to Change Without Notice

Printed in U.S.A.

**Specification Data**

APPROXIMATE  
DIMENSIONS and WEIGHTS

**NET WEIGHT:** 6120 LBS. (2776 KG.)  
**SHIPPING WEIGHT:** 6270 LBS. (2844 KG.)  
**EXPORT CRATE SIZE:** 440 CU. FT. (12,5 CU. M.)

SECTION 42, PAGE 1804

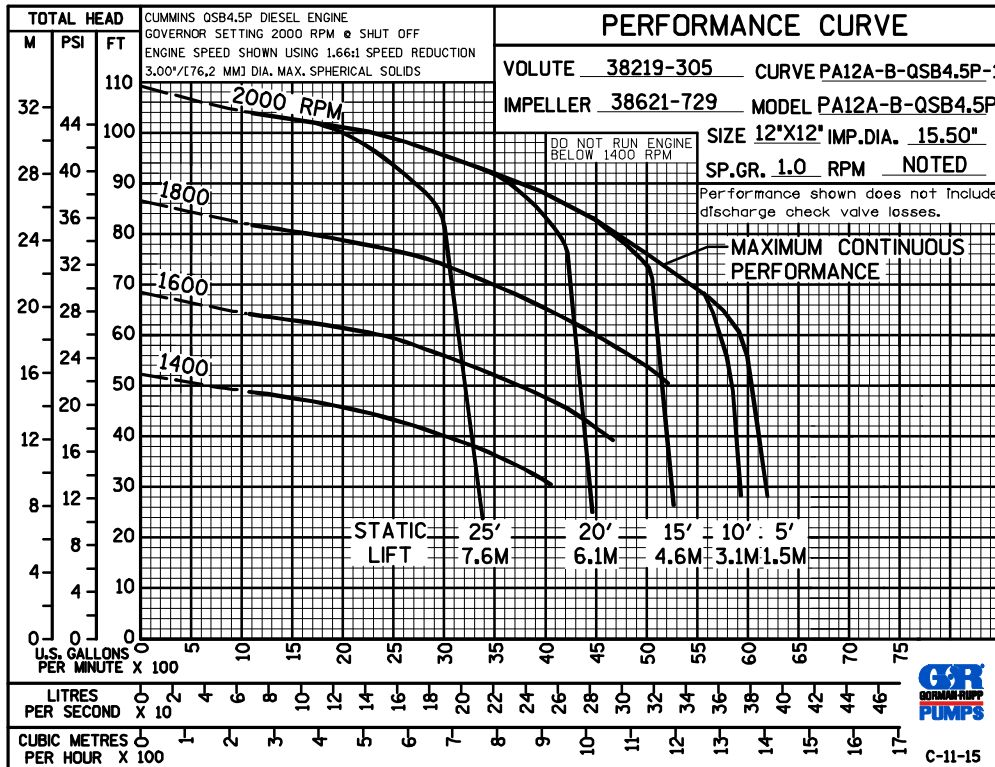
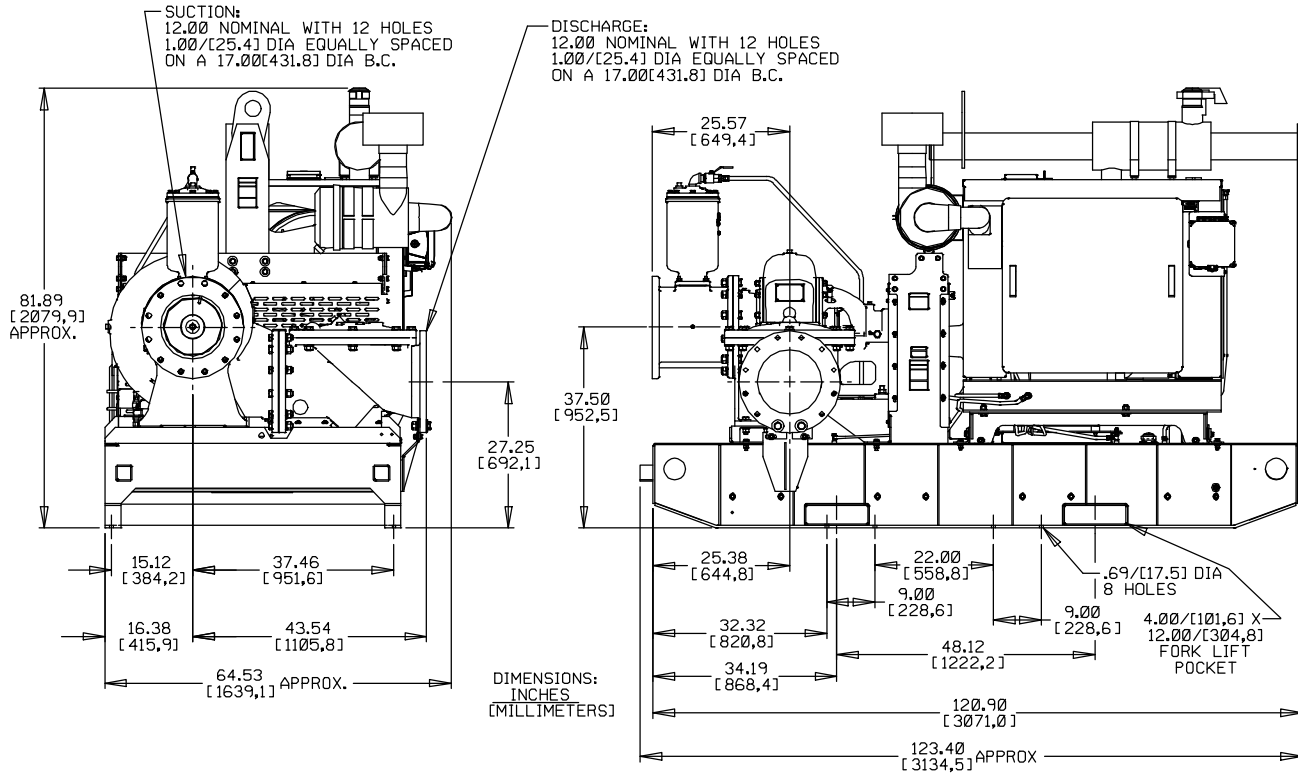

**GORMAN-RUPP PUMPS**

www.grpumps.com

Specifications Subject to Change Without Notice

Printed in U.S.A.