



Self Priming Centrifugal Pump

Model 13A52-GX390

Size 3" x 3"



Total Head		Capacity Of Pump In U.S. Gallons Per Minute (GPM) At Continuous Performance				
P.S.I.	Feet					
52.0	120	75	75	75	75	75
43.4	100	147	165	165	165	165
32.5	75	167	233	260	260	260
21.7	50	174	240	287	335	343
10.8	25	177	243	294	348	396
Suction Lift		25'	20'	15'	10'	5'



PUMP SPECIFICATIONS

Size: 3" x 3" (76 mm x 76 mm) NPT - Female.

Casing: Gray Iron 30.

Maximum Operating Pressure 94 psi (648 kPa).*

Semi-Open Type, Two Vane Impeller: Ductile Iron 65-45-12.
Handles 1 1/2" (38,1 mm) Diameter Spherical Solids.

Replaceable Wear Plate: Carbon Steel ASTM A36.

Removable Cover Plate: Gray Iron 30; 15 lbs. (6,8 kg).

Intermediate Bracket: Gray Iron 30.

Shaft Sleeve: Alloy Steel 4130.

Seal: Type 31, Mechanical, Self-Lubricated. Silicon Carbide Rotating and Stationary Faces. Fluorocarbon Elastomers (DuPont Viton® or Equivalent). Stainless Steel 304 Cage and Spring. Maximum Temperature of Liquid Pumped 160°F (71°C).*

Flap Valve: Buna-N ^{w/}Nylon Reinforcement; Gray Iron 30.

Suction Flange: Gray Iron 30.

Gaskets: Rubber and Vegetable Fiber.

Hardware: Standard Plated Steel.

Roll Cage with Rubber Feet.

90° Discharge Elbow.

Strainer.

Optional Equipment: Wheel Kit ^{w/}Semi-Pneumatic Tires.

**Consult Factory for Applications Exceeding Maximum Pressure and/or Temperature Indicated.*



ENGINE SPECIFICATIONS

Model: Honda GX390.

Type: Single Cylinder, Air Cooled, Overhead Valve, Gasoline Engine.

Displacement: 23.7 Cu. In. (388 cc).

Cylinder: Aluminum Alloy.

Governor: Mechanical.

Air Cleaner: Dual Element.

Oil Reservoir: 1.2 U.S. Qts. (1,1 liter).

Fuel Tank: 6.9 U.S. Qts. (6,5 liter).

Full Load Operating Time: 2.6 Hrs.

Starter: Recoil.

Ignition System: Transistorized Magneto.

Standard Equipment: Muffler ^{w/}Guard. Rotary Stop Switch. Manual Throttle Control ^{w/}Top Speed Limit. Manual Choke and Fuel Valve. Oil Alert™ Shut Down. Fill/Drain Ports Each Side ^{w/}Dipstick One Side Only. Spark Plug Cover.



GORMAN-RUPP PUMPS

www.grpumps.com

Specifications Subject to Change Without Notice

Printed in U.S.A.

Specification Data

SECTION 45, PAGE 680

APPROXIMATE
DIMENSIONS and WEIGHTS

NET WEIGHT: 247 LBS. (112,0 KG.)
SHIPPING WEIGHT: 328 LBS. (148,8 KG.)
EXPORT CRATE: 17.4 CU. FT. (0,5 CU. M.)
WHEEL KIT ADD 46 LBS. (21 KG.);
SHIPPING CRATE (SEPARATE) 3 CU. FT. (0,1 CU. M.)

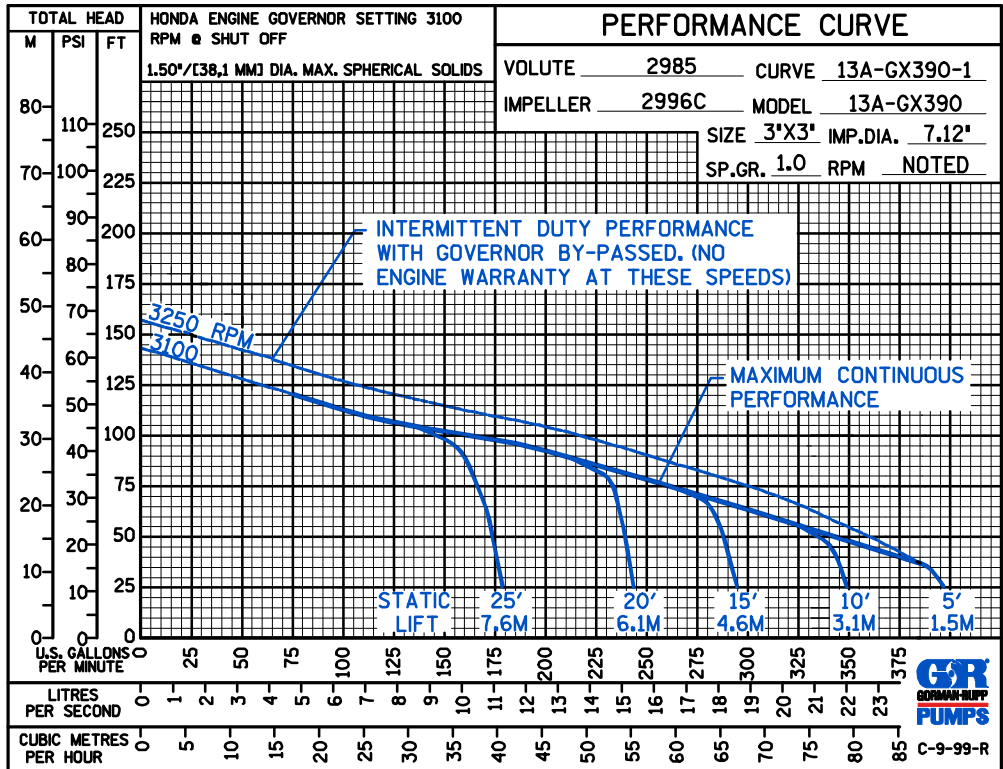
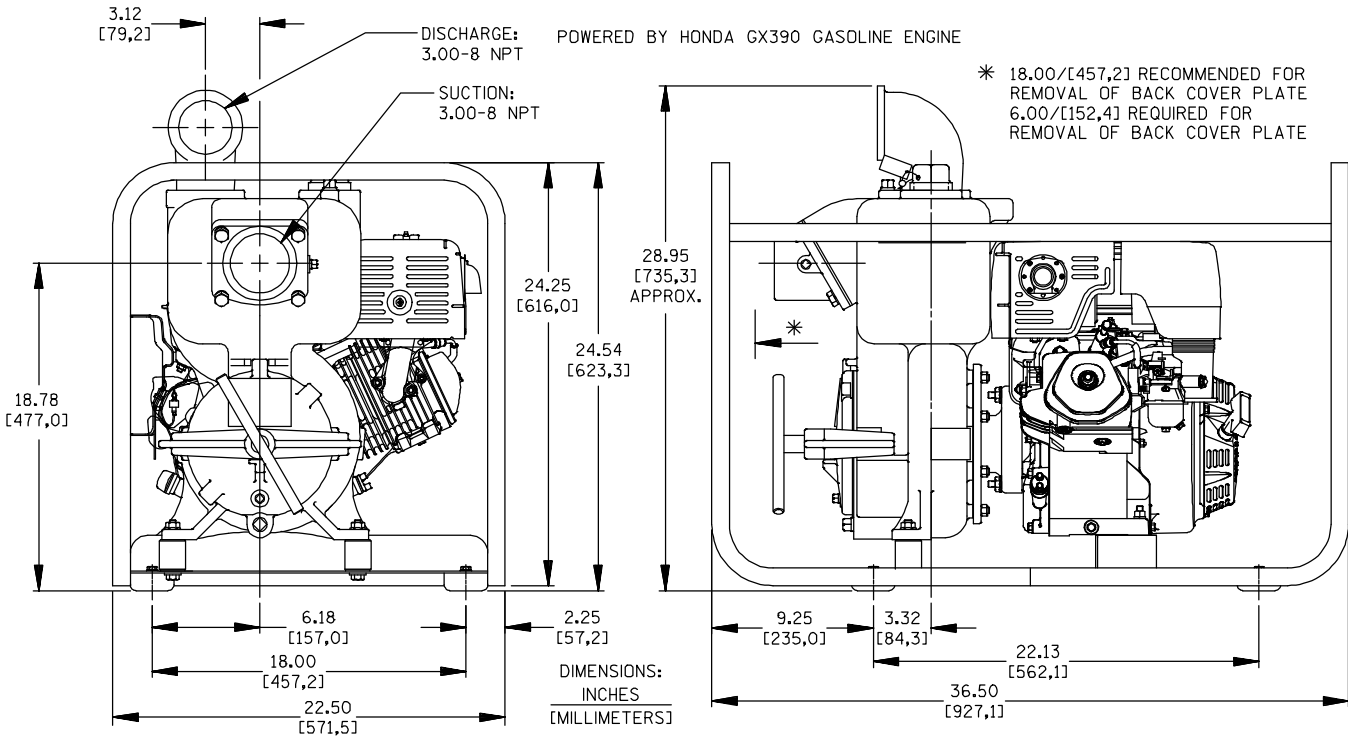

GORMAN-RUPP PUMPS

www.grpumps.com

Specifications Subject to Change Without Notice

Printed in U.S.A.