



Self Priming Centrifugal Pump

Models 16C2-4045T and 16C20-4045T

Size 6" x 6"



70 MT



Total Head		Capacity of Pump in U.S. Gallons per Minute (GPM) at Continuous Performance				
P.S.I.	Feet					
58.1	134	395	395	395	395	395
54.2	125	580	600	600	600	600
43.4	100	665	950	1140	1140	1140
32.5	75	690	960	1195	1430	1475
21.7	50	695	962	1200	1455	1560
10.8	25	700	965	1205	1465	1580
Suction Lift		25'	20'	15'	10'	5'



PUMP SPECIFICATIONS

Size: 6" x 6" (152 mm x 152 mm) NPT - Female.

Casing: Gray Iron 30.

Maximum Operating Pressure 96 psi (662 kPa).*

Semi-Open, Two Vane Impeller: Ductile Iron 65-45-12.

Handles 3" (76,2 mm) Diameter Spherical Solids.

Impeller Shaft: (16C2) Stainless Steel 17-4.

Replaceable Wear Plate: Carbon Steel ASTM A36.

Removable Cover Plate: Gray Iron 30; 36 lbs. (16 kg).

Intermediate: Gray Iron 30.

Seal Plate: Gray Iron 30.

Seal:

(16C2) Double, Grease-Lubricated w/Spring Loaded Grease Cup. Sintered Bronze Stationary Seal Seats. Steel Rotating Faces. Neoprene Packing Rings. Maximum Temperature of Liquid Pumped, 110°F (43°C). Maximum Suction Pressure 10 psi (69 kPa).*

(16C20) Type 2, Mechanical, Oil-Lubricated, Floating, Self-Aligning. Tungsten Titanium Carbide Rotating and Stationary Faces. Stainless Steel 316 Stationary Seat. Fluorocarbon Elastomers (DuPont Viton® or Equivalent). Stainless Steel 18-8 Cage and Spring. Maximum Temperature of Liquid Pumped is 160°F (71°C).*

Seal Liner: (16C2) Copper Alloy C93700.

Shaft Sleeve: (16C20) Alloy Steel 4130.

Flap Valve: Neoprene w/Steel Reinforcing.

Radial Bearing: Open Single Row Ball.

Thrust Bearing: Open Double Row Ball.

Bearing Lubrication: SAE 30 Non-Detergent Oil.

Suction Flange: Gray Iron 30.

Gaskets: Cork, Vegetable Fiber, Compressed Synthetic Fibers, and PTFE.

Hardware: Standard Plated Steel.

Standard Equipment: Hoisting Bail. Combination Skid Base w/Fuel Tank. 90° Discharge Elbow. Strainer. Oil Level Sight Gauge.

Optional Equipment: Battery. High Speed (55 MPH/89 KM/H) Single Axle Pneumatic-Tired Wheel Kit w/wo DOT-Approved Lights and Electric Brakes. [Tandem Axle Over-the-Road Trailer](#).

*Consult Factory for Applications Exceeding Maximum Pressure and/or Temperature Indicated.



ENGINE SPECIFICATIONS

Model: John Deere 4045T "Power Tech".

EPA Tier: Interim Tier 4.

Type: Four Cylinder, Four Cycle, Turbocharged, Liquid Cooled Diesel Engine.

Displacement: 276 Cu. In. (4,5 liter).

Lubrication: Forced Circulation.

Air Cleaner: Dry Type.

Fuel Tank: 61 U.S. Gals. (231 Liter).

Full Load Operating Time: 22 Hrs.

Starter: 12Volt Electric.

Standard Features: Muffler w/Weather Cap.

Optional: Electronic Fuel Level Sensor.

Engine Control Features: Padlockable Box with Throttle Control, Tachometer, Coolant Temperature, Oil Pressure, Voltage and Overstart Indicators/Shutdowns. Manual/Stop Keyswitch. Fuel Level Display/Alarm/Shutdown (For Use With Optional Fuel Level Sensor).

JOHN DEERE PUBLISHED PERFORMANCE:

Maximum Gross Intermittent
74 BHP (55 kW) @ 2400 RPM



GORMAN-RUPP PUMPS

www.grpumps.com

Specifications Subject to Change Without Notice

Printed in U.S.A.

Specification Data

SECTION 45, PAGE 1462

APPROXIMATE DIMENSIONS and WEIGHTS

SKID BASE **2-WHEEL**
NET WEIGHT: 3100 LBS. (1406 KG.) 3576 LBS. (1622 KG.)
SHIPPING WEIGHT: 3330 LBS. (1510 KG.) 3576 LBS. (1622 KG.)
EXPORT CRATE SIZE: 263 CU. FT. (3.6 CU. M.)

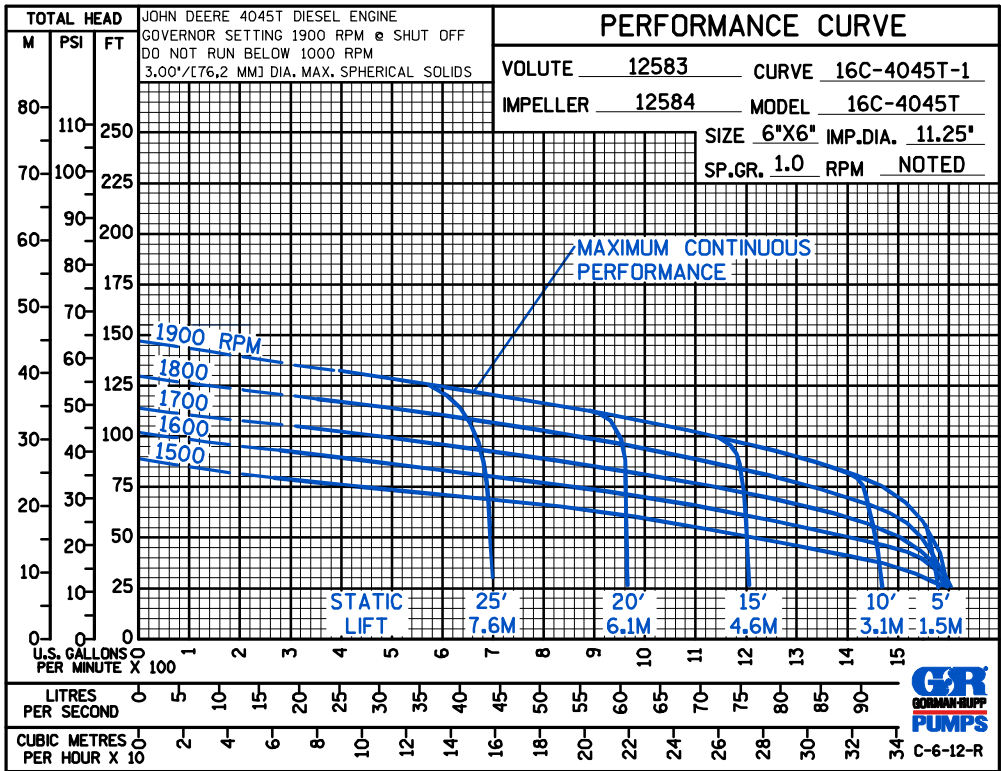
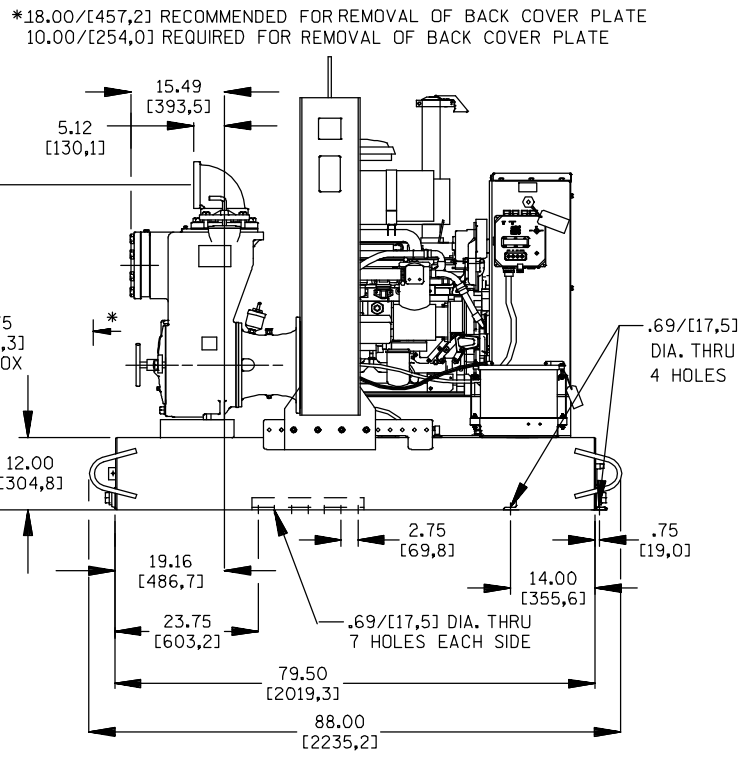
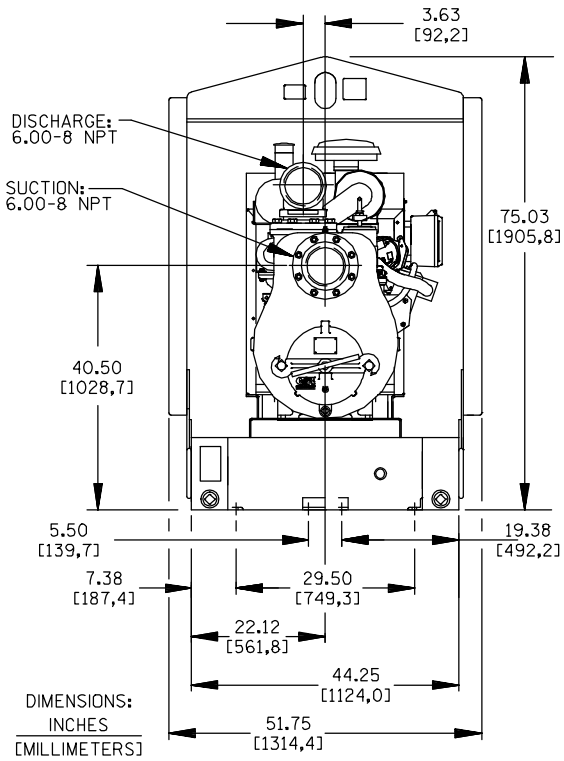

GORMAN-RUPP PUMPS

www.grpumps.com

Specifications Subject to Change Without Notice

Printed in U.S.A.