



Electric Motor Driven Stainless Steel Fitted Submersible Pump Model S4D18-E10 Size 4"



PUMP SPECIFICATIONS

- Diffuser:** Stainless Steel CD4MCu;
Maximum Operating Pressure 108 psi (747 kPa).*
- Impeller:** Stainless Steel CD4MCu.
- Wear Plate:** Stainless Steel CD4MCu.
- Seal Plate:** Stainless Steel CD4MCu.
- Intermediate:** Aluminum Alloy 356-T6.
- Casing:** Aluminum Alloy 6061-T6 with Chromicoat.
- Motor Housing:** Aluminum Alloy 356-T6.
- Motor Shaft:** Stainless Steel 416.
- Shaft Sleeve:** Stainless Steel 304.
- Bearings:** Upper - Open Single Row Ball Bearing.
Lower - Two Synthetic Seals, Double Row Ball Bearing.
- Discharge Flange:** Aluminum Alloy 356-T6.
- Gaskets:** Cork with Nitrile Binder (NC710).
- O-Rings:** Buna-N.
- Wetted Hardware:** Stainless Steel.
- Strainer:** Urethane Coated Steel; 50.6% Open Area,
0.375" (9,5 mm) Diameter Openings.
- Hoisting Bail:** Urethane Coated Steel.

Standard Equipment

NEMA Type 3R Rainproof Control Box. (See Section 130, Page 90.)

Provides On-Off, Circuit Breaker and Motor Overload Protection.

Optional Equipment

Liquid Level Control: (See Sec. 130, Page 150.)

- a. Turtle Type Pressure Activated Level Switch.
- b. Float Activated Level Switch.

Staging Adapter Kit.

MOTOR/CABLE SPECIFICATIONS

Motor: Oil Filled Enclosure; 10.0 H.P.; 3450 R.P.M.; Three Phase: 200/460/575 Volt, 60 Hz, 39/17/13.6 Full Load AMPS, 12.2 kW (Max.)

Power Cable:

200/460 Volt: 6 Wire; Type GGC; 8 AWG. 3 Power Conductors, 2 Ground Conductor and 1 Ground Check.

575 Volt: 4 Wire; Type SO/SOW/SOOW; 10 AWG; 3 Power Conductors, Plus 1 Ground.

Nominal Length 50 Feet (15 m.) Standard.
(Specify Alternate Length at Time of Order.)

Recommended Generator Size: 15 kW Across the Line Start.

* Consult Factory for Applications Exceeding Maximum Pressure and/or Temperature Indicated.

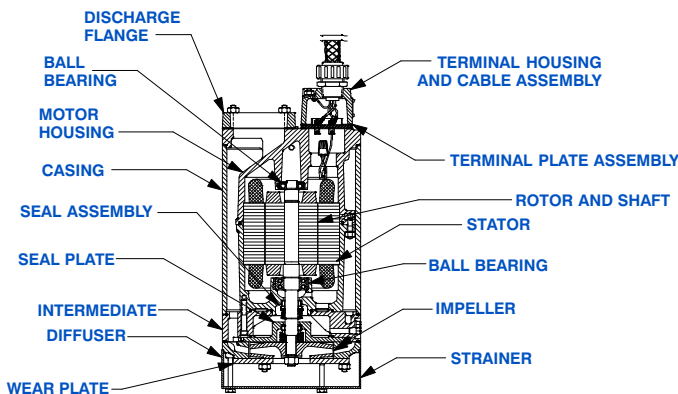
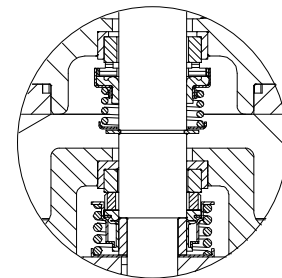

SEAL DETAIL

Tandem, Oil Lubricated.

Upper Seal: Type 21, Mechanical. Carbon Rotating Face. Ceramic Stationary Face. Buna-N Elastomers. Stainless Steel 18-8 Cage and Spring.

Lower Seal: Type 2, Mechanical. Tungsten Titanium Carbide Rotating Face and Silicon Carbide Stationary Face. Fluorocarbon Elastomers (DuPont Viton® or Equivalent). Stainless Steel 303/304 Cage and Spring.

Maximum Temperature of Liquid Pumped, 122°F (50°C).*



GORMAN-RUPP PUMPS

www.grpumps.com

Specifications Subject to Change Without Notice

Printed in U.S.A.

Specification Data

SECTION 130, PAGE 920

APPROXIMATE
DIMENSIONS and WEIGHTS

NET WEIGHT:
SHIPPING WEIGHT:
EXPORT CRATE:

242 LBS. (110 KG.)
257 LBS. (117 KG.)
11.3 CU. FT. (0,32 CU. M.)

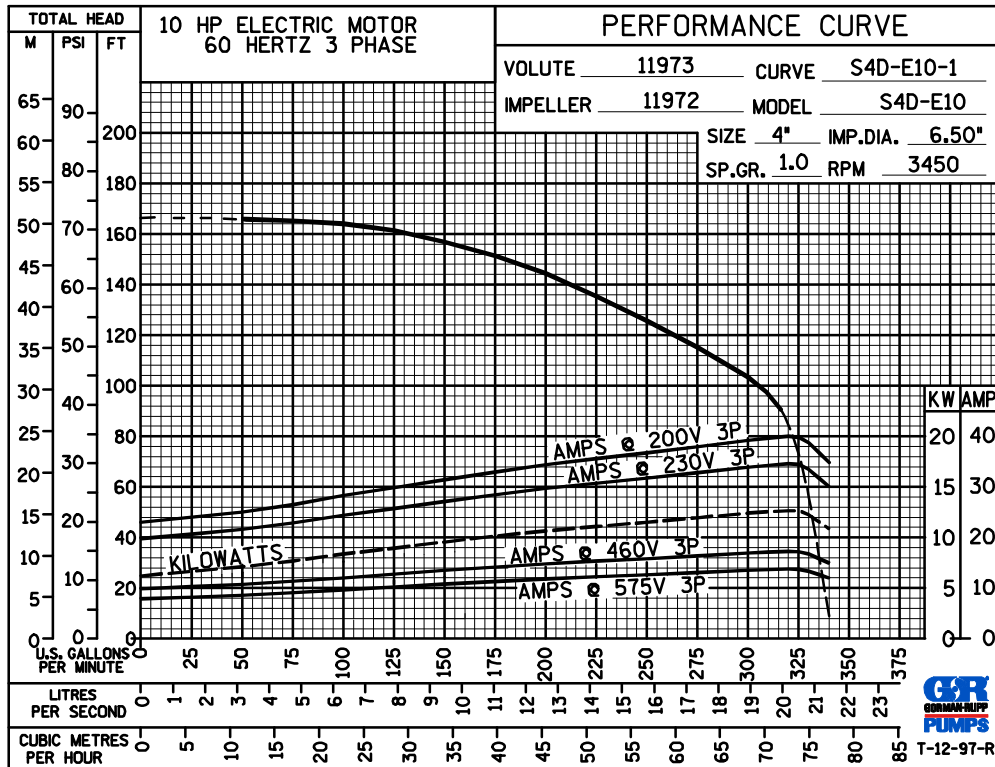
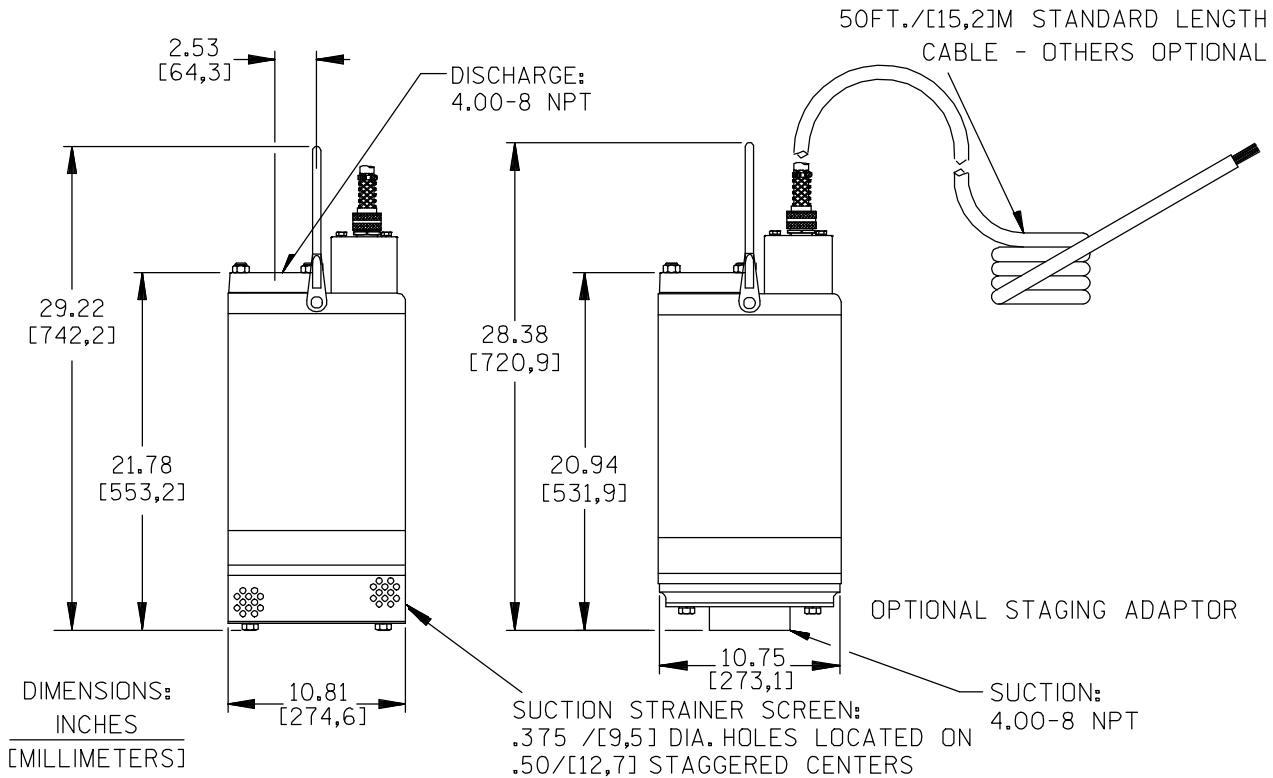

GORMAN-RUPP PUMPS

www.grpumps.com

Specifications Subject to Change Without Notice

Printed in U.S.A.