



Submersible Pump

Model S4K1-E15

Size 4"



PUMP SPECIFICATIONS

Diffuser: G-R Hard Iron;

Maximum Operating Pressure 175 psi (1207 kPa).*

Impeller: G-R Hard Iron.

Seal Plate: G-R Hard Iron.

Intermediate: Aluminum Alloy 356-T6.

Casing: Aluminum Alloy 6061-T6 with Chromicoat.

Motor Housing: Aluminum Alloy 356-T6.

Motor Shaft: Stainless Steel 416.

Shaft Sleeve: Stainless Steel 304.

Bearings: Upper, Two Synthetic Seals, Single Row Ball Bearing.
Lower, Two Shields, Double Row Ball Bearing.

Discharge Flange: Aluminum Alloy 356-T6.

Gaskets: Cork with Nitrile Binder (NC710).

O-Rings: Buna-N.

Wetted Hardware: Standard Plated Steel and Stainless Steel.

Strainer: Urethane Coated Steel; 50.6% Open Area,
0.375" (9.5 mm) Diameter Openings.

Hoisting Bail: Urethane Coated Steel.

Standard Equipment

NEMA Type 3R Rainproof Control Box. (See Section 130, Page 90.)

Provides On-Off, Circuit Breaker and Motor Overload Protection.

Staging Adapter.

Optional Equipment

Liquid Level Control: (See Sec. 130, Page 150.)

- Turtle Type Pressure Activated Level Switch.
- Float Activated Level Switch.

MOTOR/CABLE SPECIFICATIONS

Motor: Air Filled Enclosure with Thermal Overload Protection; 15 H.P.;
3450 R.P.M. Three Phase: 460/575 Volt, 60 Hz, 18/14.4 Full Load
AMPS, 13 kW (Max.)

Power Cable: 7 Wire, Type SPC; (3) 12 AWG Power Conductors,
(2) 14 AWG Control Conductors, (1) 10 AWG Ground Conductor
and (1) 14 AWG Ground Check Conductor.

Nominal Length 50 Feet (15 m). Standard.

(Specify Alternate Length at Time of Order.)

Recommended Generator Size: 15 kW. Across the Line Start.

* Consult Factory for Applications Exceeding Maximum
Pressure and/or Temperature Indicated.

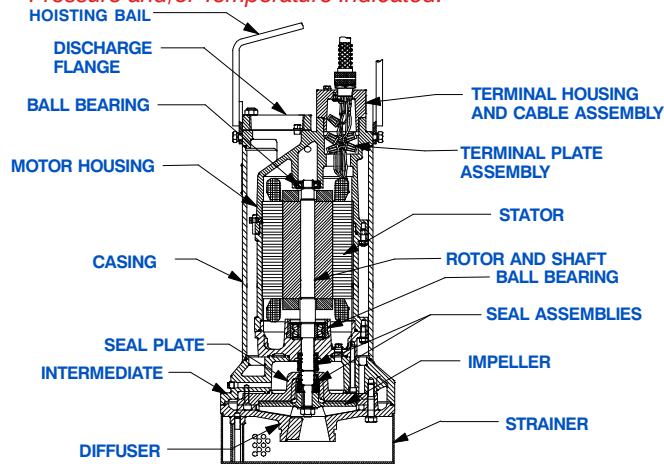

WARNING!

Do not use in explosive atmosphere or for pumping volatile flammable liquids.

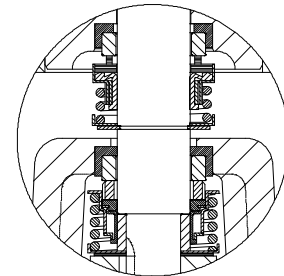

SEAL SPECIFICATIONS

Tandem, Oil Lubricated.

Upper Seal: Type 21, Mechanical. Carbon Rotating Face. Ni-Resist Stationary Face. Fluorocarbon Elastomers (DuPont Viton® or Equivalent). Stainless Steel 18-8 Cage and Spring.

Lower Seal: Type 2, Mechanical. Tungsten Titanium Carbide Rotating Face and Silicon Carbide Stationary Face. Fluorocarbon Elastomers (DuPont Viton® or Equivalent). Stainless Steel 303/304 Cage and Spring.

Maximum Temperature of Liquid Pumped, 122°F (50°C).*



GORMAN-RUPP PUMPS

www.grpumps.com

Specifications Subject to Change Without Notice

Printed in U.S.A.

Specification Data

SECTION 130, PAGE 1040

APPROXIMATE DIMENSIONS and WEIGHTS

NET WEIGHT: 372 LBS. (168,7KG.)
SHIPPING WEIGHT: 430 LBS. (195,0 KG.)
EXPORT CRATE SIZE: 10 CU. FT. (0,28 CU. M.)

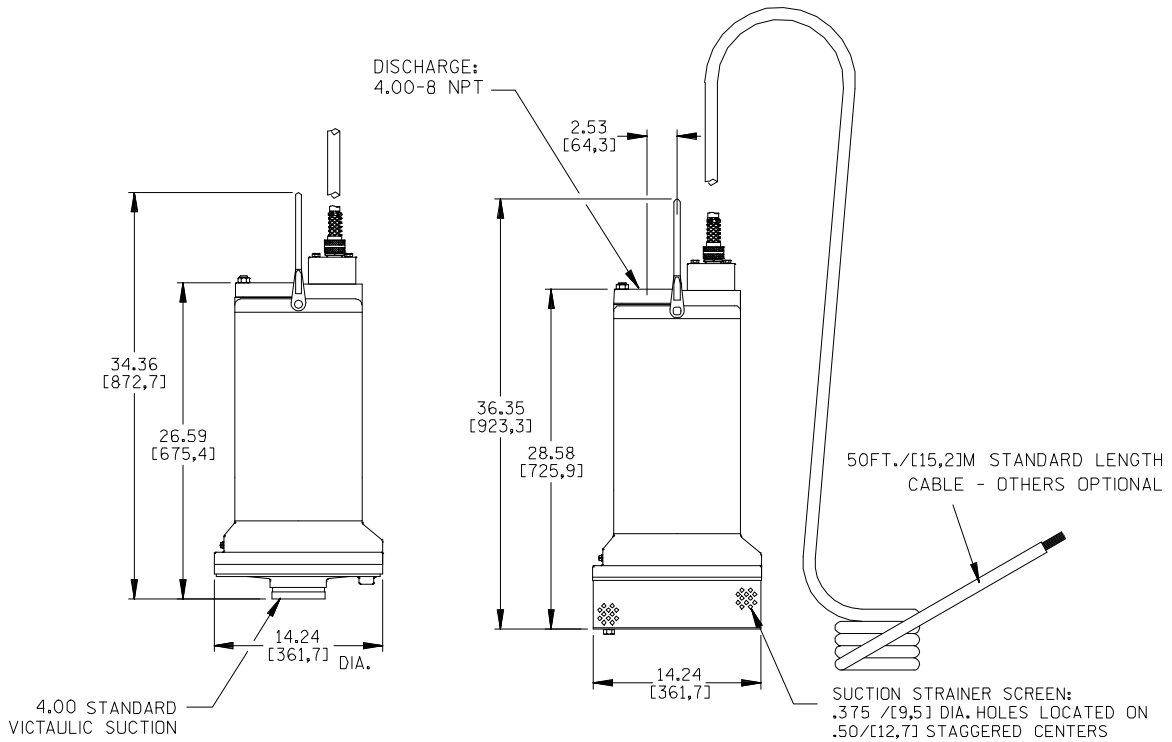

DIMENSIONS:
INCHES
[MILLIMETERS]

4.00 STANDARD VICTAULIC SUCTION

50FT./[15,2]M STANDARD LENGTH CABLE - OTHERS OPTIONAL
 SUCTION STRAINER SCREEN: .375 / [9,5] DIA. HOLES LOCATED ON .50/[12,7] STAGGERED CENTERS

Victaulic is a Registered Trademark of Victaulic Company of America.

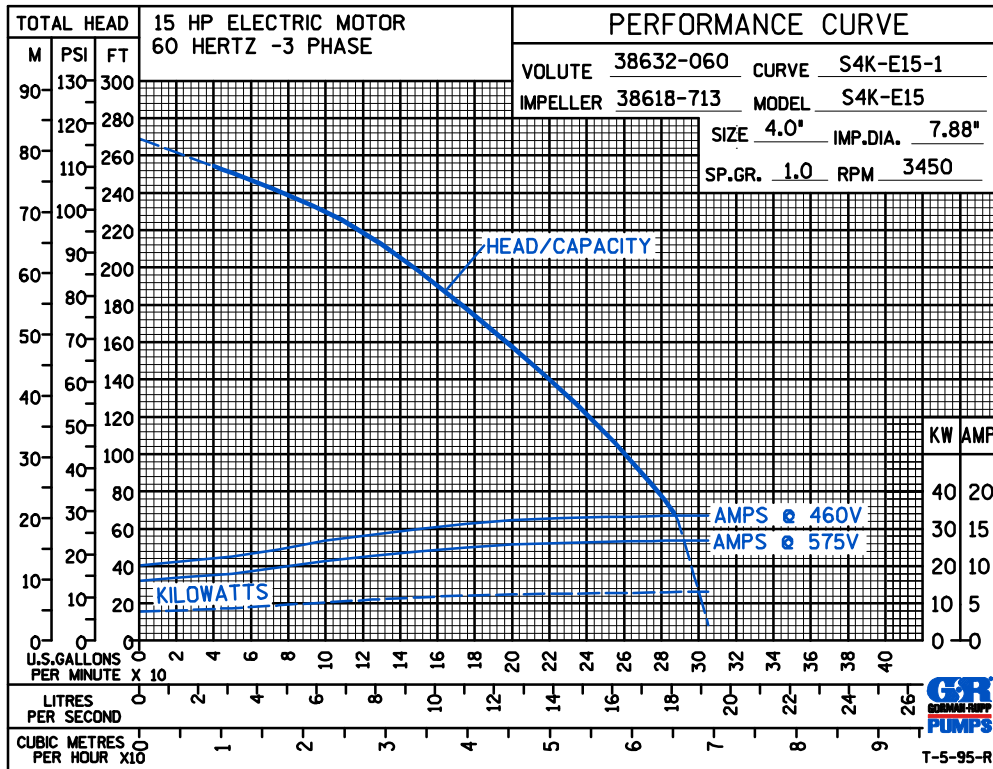

GORMAN-RUPP PUMPS

www.grpumps.com

Specifications Subject to Change Without Notice

Printed in U.S.A.