



ECH₂O STORM™

Model VA4

Size 4"

SPECIFICATIONS

Size: 4.00" ASA Flanged.
Body: Aluminum Alloy, ASTM B26.
Spool: Aluminum Alloy, ASTM B26.
Nozzle: Urethane, Hapflex 669.
Liner: PVC Schedule 80.
Gaskets: Red Rubber ASTM D-1330.
Hardware: 18-8 Stainless Steel.



Optional Equipment: Gage Kit, Check Valve Kit.

Venturi Aerator:

The Ech₂oStorm is a static venturi aeration device installed in-line on the discharge side of a Gorman-Rupp centrifugal pump that introduces dissolved oxygen into the pumped liquid. The Ech₂oStorm can be used in a variety of municipal and industrial wastewater applications including: organic solids reduction, oil and grease digestion, sulfide and nitrate elimination and odor elimination.

Operating Principle:

Liquid is pumped through the nozzle inside the Ech₂oStorm. Upon the liquid exiting the nozzle a pressure drop occurs inside the body of the Ech₂oStorm pulling atmospheric air into the Ech₂oStorm. The dissolved oxygen in the atmospheric air mixes with the pumped liquid and is discharged into the wastewater system.

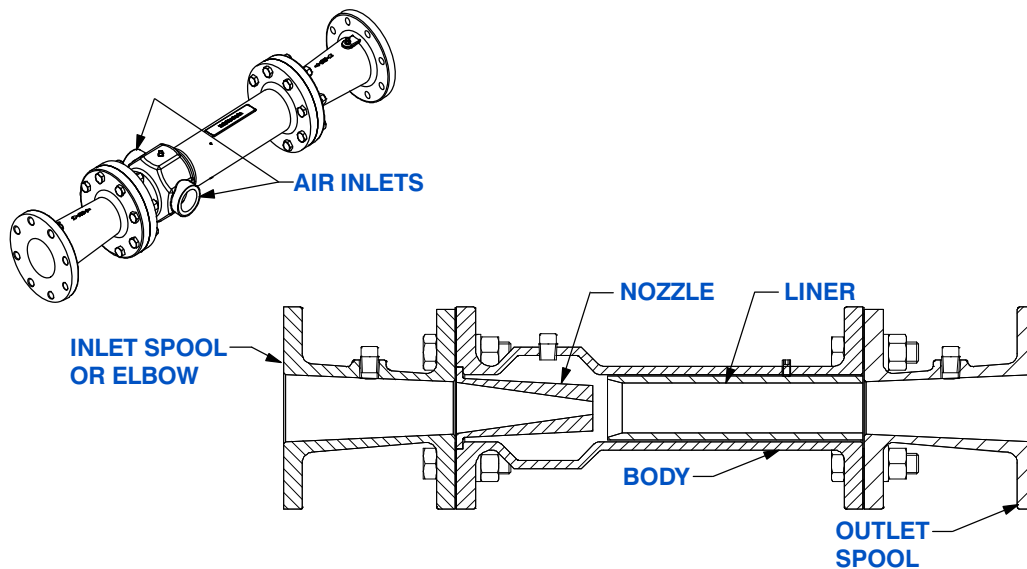

GORMAN-RUPP PUMPS

www.grpumps.com

Specifications Subject to Change Without Notice

Printed in U.S.A.

Specification Data

SECTION 160, PAGE 150.1

APPROXIMATE DIMENSIONS and WEIGHTS

NET WEIGHT: 56 LBS. (25,4 KG.)
SHIPPING WEIGHT: 60 LBS. (27,2 KG.)
EXPORT CRATE: 2.2 CU. FT. (0,06 CU. M.)

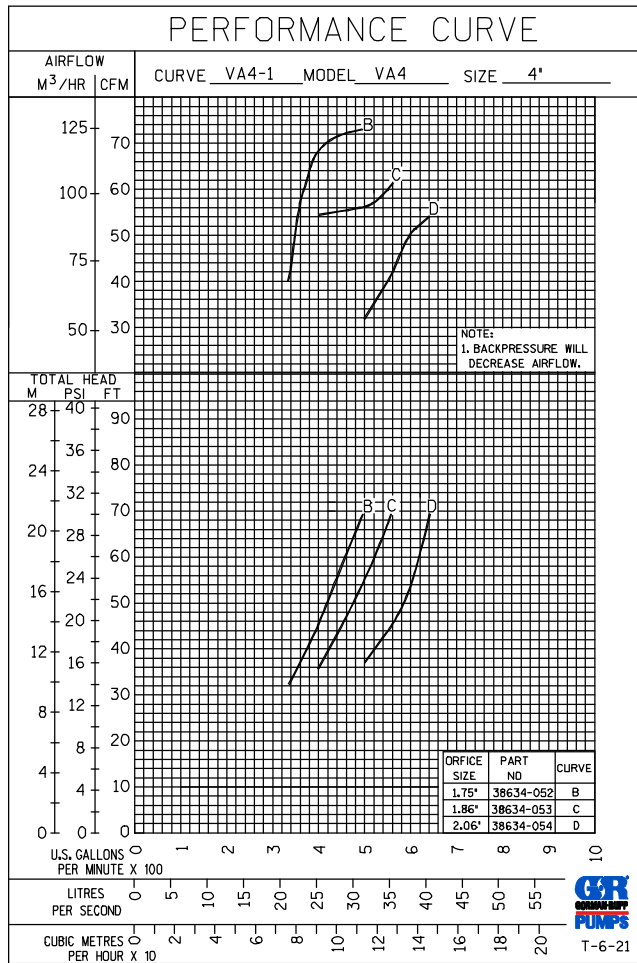
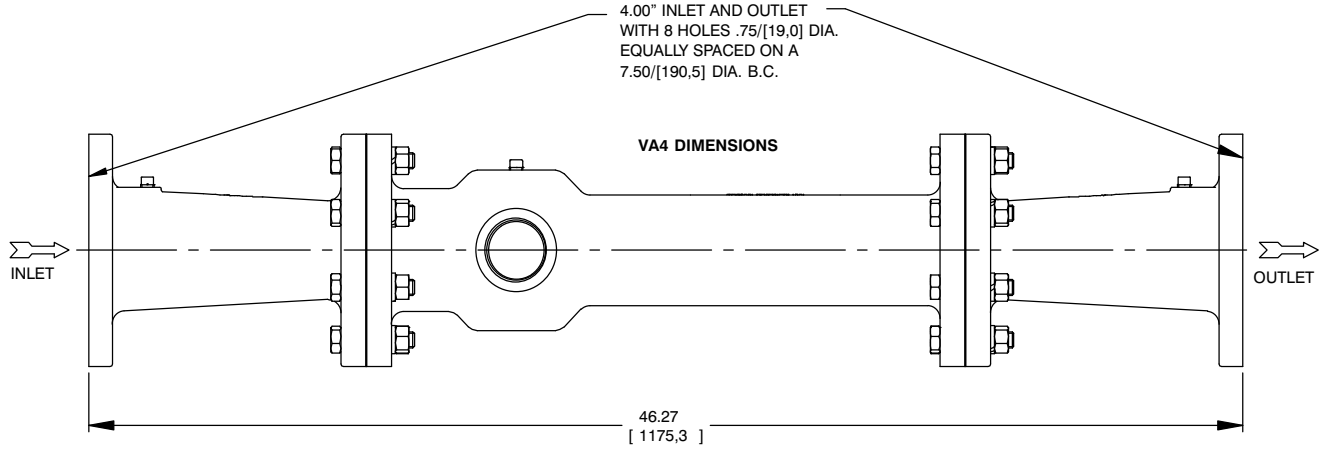

GORMAN-RUPP PUMPS

www.grpumps.com

Specifications Subject to Change Without Notice

Printed in U.S.A.